

Town of Foxborough, Massachusetts  
MA Small MS4 General Permit  
**Stormwater Management Program**



40 South Street, Foxborough, MA 02035

EPA NPDES Permit No. MAR041115

**June 30, 2022**

Prepared By:  
Department of Public Works  
Engineering Division

## Table of Contents

<b>Certification .....</b>	<b>1</b>
<b>Background.....</b>	<b>2</b>
<b>Small MS4 Authorization .....</b>	<b>3</b>
<b>Stormwater Management Program Team.....</b>	<b>4</b>
<b>Receiving Waters .....</b>	<b>5</b>
<b>Eligibility: Endangered Species and Historic Properties .....</b>	<b>7</b>
<b>MCM 1: Public Education and Outreach.....</b>	<b>8</b>
<b>MCM 2: Public Involvement and Participation .....</b>	<b>20</b>
<b>MCM 3: Illicit Discharge Detection and Elimination (IDDE) Program.....</b>	<b>23</b>
<b>MCM 4: Construction Site Stormwater Runoff Control.....</b>	<b>49</b>
<b>MCM 5: Post Construction Stormwater Management in New Development and Redevelopment .....</b>	<b>54</b>
<b>MCM 6: Good Housekeeping and Pollution Prevention for Permittee Owned Operations.....</b>	<b>62</b>
<b>TMDLs and Water Quality Limited Waters .....</b>	<b>72</b>
Charles River Watershed Phosphorus TMDL .....	72
Bacteria or Pathogens TMDL .....	72
Total Nitrogen .....	73
Total Phosphorus .....	73
Solids, Oil and Grease, or Metals .....	75



## Appendices

<b>Notice of Intent .....</b>	<b>Appendix A</b>
<b>Authorization Letter .....</b>	<b>Appendix B</b>
<b>IPaC Resource List.....</b>	<b>Appendix C</b>
<b>MS4 System Maps .....</b>	<b>Appendix D</b>
Regulated Area Map .....	D.1
MS4 System Map .....	D.2
<b>Standard Operating Procedures / O&amp;M Plans.....</b>	<b>Appendix E</b>
Dry Weather Outfall Inspection.....	SOP 1
Wet Weather Outfall Inspection.....	SOP 2
Catch Basin Inspection and Cleaning .....	SOP 3
Spill Response and Cleanup Procedures.....	SOP 4
Construction Site Inspection Procedures .....	SOP 5
Erosion and Sedimentation Control .....	SOP 6
Fuel and Oil Handling Procedures.....	SOP 7
Inspecting Constructed BMPs.....	SOP 9
Locating Illicit Discharges .....	SOP 10
Oil/Water Separator Maintenance .....	SOP 11
Storage and Use of Pesticides and Fertilizer .....	SOP 12
Water Quality Screening in the Field .....	SOP 13
Municipal Vehicle Washing .....	SOP 14
Private Drainage Connections.....	SOP 15
Street and Parking Lots .....	SOP 16
Hazardous Materials Storage and Handling .....	SOP 17

## Appendices - Cont.

Winter Road Maintenance .....	SOP 18
Operations and Maintenance of Parks and Opens Spaces.....	SOP 19
Operations and Maintenance of Municipal Buildings and Facilities .....	SOP 20
Operations and Maintenance of Municipal Vehicles and Equipment .....	SOP 21
<b>Sewer System Overflow (SSO) Inventory .....</b>	<b>Appendix F</b>
<b>Outfall Priority Ranking .....</b>	<b>Appendix G</b>
<b>Stormwater Pollution Prevention Plans.....</b>	<b>Appendix H</b>
Department of Public Works (70 Elm Street) .....	H.1
<b>Dry Weather Outfall Inspection Results.....</b>	<b>Appendix I</b>
<b>Report on Impervious Area and Green Infrastructure Practices.....</b>	<b>Appendix J</b>
<b>Inventory of Municipal BMP Retrofit Opportunities .....</b>	<b>Appendix K</b>
<b>Nutrient Source Identification Report.....</b>	<b>Appendix L</b>

## Certification

**Authorized Representative (Optional):** All reports, including SWPPPs, inspection reports, annual reports, monitoring reports, reports on training and other information required by this permit must be signed by a person described in Appendix B, Subsection 11.A of the MS4 Permit or by a duly authorized representative of that person in accordance with Appendix B, Subsection 11.B. If there is an authorized representative to sign MS4 reports, there must be a signed and dated written authorization.

The authorization letter is:

Attached to this document (document name listed below):

---

Publicly available at the website below:

---

"I certify under penalty of law that this document and all attachments were prepared under my direction or supervision in accordance with a system designed to assure that qualified personnel properly gathered and evaluated the information submitted. Based on my inquiry of the person or persons who manage the system, or those persons directly responsible for gathering the information, the information submitted is, to the best of my knowledge and belief, true, accurate, and complete. I am aware that there are significant penalties for submitting false information, including the possibility of fine and imprisonment for knowing violations."

Printed Name: William Keegan, Jr., Town Manager

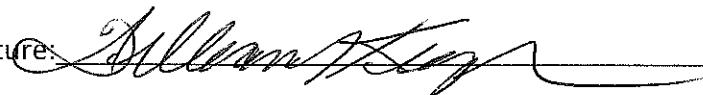
Signature: 

Date: 9/25/2022



## Background

### Stormwater Regulation

The Stormwater Phase II Final Rule was promulgated in 1999 and was the next step after the 1987 Phase I Rule in EPA's effort to preserve, protect, and improve the Nation's water resources from polluted stormwater runoff. The Phase II program expands the Phase I program by requiring additional operators of MS4s in urbanized areas and operators of small construction sites, through the use of NPDES permits, to implement programs and practices to control polluted stormwater runoff. Phase II is intended to further reduce adverse impacts to water quality and aquatic habitat by instituting the use of controls on the unregulated sources of stormwater discharges that have the greatest likelihood of causing continued environmental degradation. Under the Phase II rule all MS4s with stormwater discharges from Census designated Urbanized Area are required to seek NPDES permit coverage for those stormwater discharges.

### Permit Program Background

On May 1, 2003, EPA Region 1 issued its Final General Permit for Stormwater Discharges from Small Municipal Separate Storm Sewer Systems (2003 small MS4 permit) consistent with the Phase II rule. The 2003 small MS4 permit covered "traditional" (i.e., cities and towns) and "non-traditional" (i.e., Federal and state agencies) MS4 Operators located in the states of Massachusetts and New Hampshire. This permit expired on May 1, 2008 but remained in effect until operators were authorized under the 2016 MS4 general permit, which became effective on July 1, 2018.

### Stormwater Management Program (SWMP)

The SWMP describes and details the activities and measures that will be implemented to meet the terms and conditions of the permit. The SWMP accurately describes the permittees plans and activities. The document should be updated and/or modified during the permit term as the permittee's activities are modified, changed or updated to meet permit conditions during the permit term. The main elements of the stormwater management program are (1) a public education program in order to affect public behavior causing stormwater pollution, (2) an opportunity for the public to participate and provide comments on the stormwater program (3) a program to effectively find and eliminate illicit discharges within the MS4 (4) a program to effectively control construction site stormwater discharges to the MS4 (5) a program to ensure that stormwater from development projects entering the MS4 is adequately controlled by the construction of stormwater controls, and (6) a good housekeeping program to ensure that stormwater

## Small MS4 Authorization

### **Notice of Intent**

The Notice of Intent (NOI) was submitted on September 28<sup>th</sup>, 2018.

The NOI can be found at the following (document location or web address):

---

**Appendix A: Notice of Intent**

---

### **Authorization Letter**

Authorization to Discharge was granted April 5<sup>th</sup>, 2019.

The Authorization Letter can be found at the following (document location or web address):

---

**Appendix B: Authorization Letter**

---

# Stormwater Management Program Team

## SWMP Team Coordinator

Name/Title: William Keegan, Town Manager

Responsibilities: Authorized Representative

## SWMP Team

Name/Title: Planning Board

Responsibilities: Stormwater Authority / MCM4, MCM5

Name/Title: Department of Public Works

Responsibilities: MCM2, MCM3, MCM6, TMDL and Impaired Waters

Name/Title: Conservation Commission

Responsibilities: MCM4

Name/Title: Neponset Stormwater Partnership

Responsibilities: MCM1, MCM2, MCM5

Name/Title: Building Permitting and Enforcement

Responsibilities: MCM4



## Receiving Waters

The following table lists all receiving waters, impairments and number of outfalls discharging to each waterbody segment. Data was compiled from the December 2019, Final Massachusetts Year 2016 Integrated List of Waters.

Water Body	Watershed	SegmentID	Category	Outfalls	Impairment	EPA TMDL No.
Canoe River	Taunton	MA62-64	2			
Canoe River	Taunton	MA62-65	2			
Beaumont Pond	Taunton	MA62009	3			
Carpenter Pond	Taunton	MA62032	3			
Cocasset Lake	Taunton	MA62043	3			
Furnace Lake	Taunton	MA62076	3			
Sunset Lake	Taunton	MA62184	3			
Gavins Pond	Taunton	MA62077	4c		(Non-Native Aquatic Plants*)	
Lake Mirimichi	Taunton	MA62118	4c		(Non-Native Aquatic Plants*)	
Ganawatte Farm Pond	Boston Harbor: Neponset	MA73037	5		Aquatic Plants (Macrophytes) Dissolved Oxygen Transparency / Clarity	
Neponset Reservoir	Boston Harbor: Neponset	MA73034	5		(Non-Native Aquatic Plants*) Algae Turbidity	
Neponset River	Boston Harbor: Neponset	MA73-01	5		DDT in Fish Tissue Dissolved Oxygen Escherichia Coli (E. Coli) Metals Nutrient/Eutrophication Biological Indicators PCBs in Fish Tissue Phosphorus, Total	54840
Glue Factory Pond	Taunton	MA62078	5		(Physical substrate habitat alterations*) Benthic Macroinvertebrates Fish Bioassessments Sedimentation/Siltation	
Robinson Brook	Taunton	MA62-14	5		(Physical substrate habitat alterations*) Benthic Macroinvertebrates	

\*TMDL not required (Non-pollutant)

## Receiving Waters - Continued

Water Body	Watershed	SegmentID	Category	Outfalls	Impairment	EPA TMDL No.
Rumford River	Taunton	MA62-62	5		(Non-Native Aquatic Plants*) (Physical substrate habitat alterations*) Benthic Macroinvertebrates Fish Bioassessments Sedimentation/Siltation	
Rumford River	Taunton	MA62-63	5		(Physical substrate habitat alterations*) Benthic Macroinvertebrates Dioxin (including 2,3, 7, 8-TCDD) Fish Bioassessments Pentachlorophenol (PCP) Sedmination/Siltation	
Wading River	Taunton	MA62-47	5		Algae Dissolved Oxygen	
Plain Street Pond	Ten Mile	MA52032	5		(Non-Native Aquatic Plants*) Algae	

\*TMDL not required (Non-pollutant)

## Eligibility: Endangered Species and Historic Properties

### Endangered Species Act (ESA) Eligibility Determination

Foxborough has completed the ESA eligibility process outlined in the MS4 Permit Appendix C. According to the U.S. Fish & Wildlife Service (USFWS) Information for Planning and Consultation (IPaC) tool, Foxborough contains potential habitat for the Northern Long-eared Bat, which is listed as a threatened species. The IPaC printout is provided in **Appendix C**.

Foxborough has determined that the stormwater discharges and discharge related activities will have no effect on any federally threatened or endangered listed species or designated critical habitat under jurisdiction of the USFWS. If, during the course of the permit term, Foxborough plans to install a structural BMP not identified in the NOI, Foxborough will conduct an endangered species screening for the proposed site and will contact the USFWS if Foxborough determines that the new activity "may affect" or is "not likely to adversely affect" listed species or critical habitat under jurisdiction of the USFWS.

In accordance with the ESA eligibility process outlined in the MS4 Permit Appendix C, Foxborough certifies permit eligibility with the ESA under Criterion C.

USFWS Criterion C: *Using the best scientific and commercial data available, the effect of the stormwater discharge and discharge related activities on listed species and critical habitat have been evaluated. Based on those evaluations, a determination is made by EPA, or by the applicant and affirmed by EPA, that the stormwater discharges and discharge related activities will have "no affect" on any federally threatened or endangered listed species or designated critical habitat under the jurisdiction of the USFWS.*

### National Historic Preservation Act (NHPA) Eligibility Determination

Foxborough has completed the NHPA eligibility process outlined in the MS4 Permit Appendix D. Foxborough is an existing facility authorized by the previous MS4 permit. Foxborough's discharge and discharge-related activities do not have the potential to cause effects on historic properties.

In accordance with the NHPA eligibility process outlined in the MS4 Permit Appendix D, Foxborough certifies permit eligibility with the ESA under Criterion A.

NHPA Criterion A: *The discharges do not have the potential to cause effects on historic properties.*



# MCM 1: Public Education and Outreach

Permit Part 2.3.2

## Objectives

The permittee shall implement an education program that includes educational goals based on stormwater issues of significance within the MS4 area. The ultimate objective of a public education program is to increase knowledge and change behavior of the public so that the pollutants in stormwater are reduced.

Category: Public Education		Due Yr	Update	Reference / Remarks
1.1	Spring message to residents/ businesses/ institutions re: grass clippings and fertilizer	1	annually	See Appendix H.II. Should be sent April/May.
1.2	Message to residents/ businesses/ institutions re: pet waste	1	annually	See Appendix F.III and/or Appendix H.III, and Appendix H.II. Note H.II calls for delivery in summer (June/July) and requires including businesses. Message should note ordinances.
1.3	Fall message residents/ businesses/ institutions re: leaf waste	1	annually	See Appendix H.II
1.4	Message with dog license issuance and renewals	1	annually	See Appendix F.III and Appendix H.III.
1.5	Message to residential audience	4	none	See 2.3.2. Messages to each audience must be spaced a year apart. Program must have defined educational goals.
1.6	Message to business/ institutional / commercial audience	4	none	See 2.3.2. Messages to each audience must be spaced a year apart.
1.7	Message to developer/ construction audience	4	none	See 2.3.2. Messages to each audience must be spaced a year apart.
1.7	Message to industrial audience	4	none	See 2.3.2. Messages to each audience must be spaced a year apart.
1.9	Message to residential audience	5	none	See 2.3.2. Messages to each audience must be spaced a year apart.
1.10	Message to business/ institutional / commercial audience	5	none	See 2.3.2. Messages to each audience must be spaced a year apart.
1.11	Message to developer/ construction audience	5	none	See 2.3.2. Messages to each audience must be spaced a year apart.
1.12	Message to industrial audience	5	none	See 2.3.2. Messages to each audience must be spaced a year apart.
1.13	Message to septic system owners	5	none	See Appendix F.III and/or Appendix H.III. Only required for septic owners in catchments of bacteria impaired / TMDL waters.

## **Background and Goals**

The Town and its partners will implement a public outreach and education program that complements and supports other activities planned under its SWMP.

The goals of the Town's public outreach and education program are to:

- Achieve compliance with public outreach and education requirements contained in the MS4 permit, including TMDL and impaired waters requirements for bacteria and nutrients.
- Increase awareness of the impact of stormwater pollution on water bodies in the Town, especially impaired and priority waters.
- Increase public awareness of the work being done by the Town to maintain and improve stormwater infrastructure, and the economic, recreational, water supply, and ecological benefits of that work.
- Increase awareness of how the public can support and assist the Town in implementing an effective stormwater management program.
- Encourage individuals and organizations to adopt habits and engage in voluntary actions that increase groundwater recharge, decrease pollutant loading, and decrease peak discharge rates, thereby reducing the burden placed on public stormwater infrastructure and the environment.
- For sites regulated by the Town under the Wetlands Act and/or the Town's stormwater bylaw, increase the quality of stormwater permit applications and the level of voluntary compliance with permit conditions and ongoing O&M requirements, while reducing the need for municipal regulators to take enforcement action.

## **Responsible Parties and Regional Implementation Strategy**

The Town has joined with its neighboring communities to implement its public education and outreach program on a regional basis through the Neponset Stormwater Partnership (NSP).

One or more designated representatives from the Town participate in the meetings of the NSP to supervise the development, implementation, evaluation and revisions to the NSP regional public outreach and education program. The NSP Outreach Sub-committee develops an outreach and education work plan and budget each year, the implementation of which is funded by the Town in conjunction with other participating communities. The goal of this regional approach is to increase the effectiveness and reduce the cost of the public outreach and education program, relative to what could be achieved through a program implemented by the Town working on its own.

The Town's stormwater Outreach and Education Coordinator is:

- Town Engineer

Key contacts with the NSP responsible for day to day planning, management and implementation of the NSP Outreach and Education Program include:

- Nancy Fyler, Outreach Director, Neponset River Watershed Association
- Ian Cooke, Executive Director, Neponset River Watershed Association

The above named individuals are responsible for ensuring that the outreach and education program is implemented in accordance with this SWMP.

### **Targeted Audiences and Key Topics and Messages**

The Town's outreach and education program targets four key audiences as specified in the MS4 Permit:

- 1) Residents
- 2) Businesses, Institutions and Commercial Facilities
- 3) The Development and Construction Sector
- 4) Industrial Facilities

The Town has considered the topics listed in Part 2.3.2.d.i-iv of the MS4 Permit for each of the above target audiences. Based on this review, the Town has identified the following topics and messages as priorities for dissemination to each of the target audiences given local conditions.

#### Residents

This audience includes the general residential population of the community including small residential property owners and renters. Because many of the leaders in the business, industrial and construction industries are also local residents, the residential program will help to provide a base of knowledge for these other audiences as well. The key messages to be conveyed and/or behaviors to be encouraged for this audience include:

- Polluted stormwater is created when rain falls on impervious surfaces or unstable soils, collects pollutants, and makes its way directly or indirectly to streams and wetlands.
- Residential stormwater pollution is the result of a wide variety of common activities including pet waste management, lawn care, automotive maintenance, disposal of swimming pool water, and failing septic systems, among others.
- We are all responsible for stormwater pollution.
- Stormwater runoff is the largest source of pollution to local waterways.
- Stormwater pollution negatively impacts drinking water, recreation, wildlife habitats, and flooding in our community or neighboring communities.
- Most storm drains lead to streams or wetlands with minimal treatment.
- Keeping impervious surfaces clean, in addition to the storm drain itself, is essential to preventing the discharge of pollutants and reducing maintenance costs.
- Bacteria and nutrients are particular pollutants of concern in our area.
- Bacterial pollution can be reduced by properly disposing of pet waste, properly using/maintaining septic systems, and properly managing garbage.



- Nutrient pollution can be reduced by properly managing landscaping activities and landscape waste materials, properly disposing of pet waste, properly using/maintaining septic systems, preventing erosion, and properly managing garbage.
- Other common household pollutants should be stored and used or disposed of properly including but not limited to oil, pharmaceuticals, car washing chemicals, swimming pool chemicals, swimming pool water, and deicing chemicals.
- There are a variety of simple steps homeowners can implement on their own property to help increase groundwater recharge and reduce pollutant loading.
- Naturally vegetated buffers should be maintained along waterways and wetlands.
- Dumping of yard wastes or other debris into waterways and wetlands is illegal and contributes to water pollution.

### Businesses, Institutions and Commercial Facilities

This audience includes all non-residential property owners and lessors with the exception of industrial property. In addition, the owners/managers of large residential properties (apartment complexes) are included in this group. This is a very diverse audience category. The key messages to be conveyed and/or behaviors to be encouraged for this audience include:

- Polluted stormwater is created when rain falls on impervious surfaces or unstable soils, collects pollutants, and makes its way directly or indirectly to streams and wetlands.
- Commercial stormwater pollution is the result of a wide variety of common activities including lawn care, construction activities, management of liquid and solid wastes and dumpsters, building maintenance, fleet maintenance, parking lot maintenance, de-icing activities, septic system management, disposal of swimming pool water, and pet waste management, among others.
- We are all responsible for stormwater pollution.
- Stormwater runoff is the largest source of pollution to local waterways.
- Stormwater pollution negatively impacts drinking water, recreation, wildlife habitats, and flooding in our community or neighboring communities.
- Most storm drains (both public and private) lead to streams or wetlands with minimal treatment.
- Keeping impervious surfaces clean, in addition to the storm drain itself, is essential to preventing the discharge of pollutants, and reducing maintenance costs.
- Bacteria and nutrients are particular pollutants of concern in our area.
- Bacterial pollution can be reduced by properly disposing of pet waste, properly using/maintaining septic systems, properly managing garbage, and preventing illicit discharges.
- Nutrient pollution can be reduced by properly managing landscaping activities and landscape waste materials, properly disposing of pet waste, properly using/maintaining septic systems, properly managing garbage, and preventing illicit discharges.

- Other common pollutants should be stored and used or disposed of properly including but not limited to oil, vehicle/building/pavement washing chemicals, pool water, and deicing chemicals.
- Proper training of employees and/or customers is essential to preventing pollution.
- Many private properties have stormwater permit requirements through the wetlands act and/or local wetlands/stormwater bylaws which require ongoing operation and maintenance activities and/or reporting.
- New development and redevelopment may trigger the need for a permit and upgrading of stormwater BMPs.
- There are a variety of simple pollution prevention and green infrastructure measures property owners can implement to help increase groundwater recharge and reduce pollutant loading.
- Naturally vegetated buffers should be maintained along waterways and wetlands.
- Dumping of yard wastes, snow or other debris into waterways and wetlands is illegal and contributes to water pollution.

### Development and Construction Sectors

The development and construction sector includes private developers, construction contractors, and the engineers, attorneys and others who assist them. The key messages to be conveyed and/or behaviors to be encouraged for this audience include:

- Polluted stormwater is created when rain falls on impervious surfaces or unstable soils, collects pollutants, and makes its way directly or indirectly to streams and wetlands.
- Stormwater runoff is the largest source of pollution to local waterways.
- Stormwater pollution negatively impacts drinking water, recreation, wildlife habitats, and flooding in our community or neighboring communities.
- Construction site sedimentation and erosion is a significant water quality problem.
- Construction site sedimentation and erosion controls need to be properly designed, maintained and installed to protect waterways and avoid the cost of enforcement actions by local regulators.
- Local and federal stormwater and/or wetlands permit applications are required for most development and redevelopment projects.
- Construction and post-construction stormwater controls will be required of most permit applicants under the MA Wetlands Protection Act, local bylaws and/or the EPA Construction General Permit.
- TMDLs for bacteria and/or nutrients apply to projects in our area and permit applicants must propose BMPs that are consistent with or optimized for TMDL requirements.
- Permit applicants are encouraged to propose Low Impact Development and/or Green Infrastructure techniques which offer a variety of environmental benefits as well as potential cost savings.

- Sediment management, pollution prevention, and compliance with wetlands act resource area protections is also critical at construction equipment and material storage yards.
- Permitting standards are changing or have changed with the revision of the MS4 permit, MA Stormwater Handbook and the Town's stormwater bylaws, and construction industry representatives need to understand and comply with these changes.

### Industrial Facilities

For purposes of the outreach and education SWMP industrial facilities are considered to include all properties which are engaged in the manufacture, processing, and storage of manufactured goods and materials. Some facilities in this category may be regulated by the EPA Multi-Sector General Permit. The key messages to be conveyed and/or behaviors to be encouraged for this audience include:

- Polluted stormwater is created when rain falls on impervious surfaces or unstable soils, collects pollutants, and makes its way directly or indirectly to streams and wetlands.
- Industrial stormwater pollution is the result of a wide variety of common activities including lawn care, construction activities, management of liquid and solid wastes and dumpsters, storage of raw materials, building maintenance, fleet maintenance, parking lot maintenance, and septic system management, among others.
- We are all responsible for stormwater pollution.
- Stormwater runoff is the largest source of pollution to local waterways.
- Stormwater pollution negatively impacts drinking water, recreation, wildlife habitats, and flooding in our community or neighboring communities.
- Most storm drains (both public and private) lead to streams or wetlands with minimal treatment.
- Keeping impervious surfaces clean, in addition to the storm drain itself, is essential to preventing the discharge of pollutants, and reducing maintenance costs.
- Bacteria and nutrients are particular pollutants of concern in our area.
- Bacterial pollution can be reduced by properly disposing of pet waste, properly using/maintaining septic systems, properly managing garbage, and preventing illicit discharges.
- Nutrient pollution can be reduced by properly managing landscaping activities and landscape waste materials, properly disposing of pet waste, properly using/maintaining septic systems, properly managing garbage, and preventing illicit discharges.
- Other common pollutants should be stored and used or disposed of properly including but not limited to oil, material stockpiles, vehicle/building/pavement washing chemicals, and deicing chemicals.
- Proper training of employees and/or customers is essential to preventing pollution.

- Many properties have stormwater permit requirements through the wetlands act, local wetlands/stormwater bylaws or the MSGP which require ongoing operation and maintenance activities and reporting.
- New development and redevelopment may trigger the need for a permit and upgrading of stormwater BMPs.
- There are a variety of simple green infrastructure measures property owners can implement to help increase groundwater recharge and reduce pollutant loading.
- Naturally vegetated buffers should be maintained along waterways and wetlands and dumping of yard wastes, snow or other debris into waterways and wetlands is illegal.
- Many industrial properties have specific permitting and compliance requirements under the EPA Multi-Sector General Permit.

### **Message Distribution Requirements**

Section 2.3 of the MS4 Permit requires the distribution of two messages to each of the four target audiences over the five year permit period, with each message to the same audience spaced at least one year apart.

In addition to these basic requirements, the Town is subject to additional requirements as a result of one or more bacteria TMDLs as described in Appendix F of the permit. These additional requirements include:

- An annual message to residents on proper pet waste management and any local pet waste bylaws.
- Inclusion of pet waste management information with new or renewed dog licenses.
- A message to septic system owners on proper system maintenance.

Furthermore, under the provisions of Section 2.2.2 and Appendix H of the MS4 Permit, the Town is subject to additional requirements because it discharges to one or more water bodies that is water quality limited for phosphorous and/or nitrogen. These education requirements are in addition to the basic requirements of Section 2.3 of the MS4 Permit, but as the Town interprets the Permit, may be implemented concurrently with the special requirements for the bacteria TMDL(s) described above. These messages are required unless the Town documents that one or more of the following sources is an insignificant contributor of nitrogen or phosphorous to the MS4. These requirements include:

- An annual spring (March or April) message to resident and business audiences regarding proper use and disposal of grass clippings and slow-release and phosphorous-free fertilizers.
- An annual summer (June or July) message to residents and business audiences regarding proper management of pet waste, including any local pet waste ordinances.
- An annual fall (August, September or October) message to residents and business audiences regarding proper disposal of leaf litter.

## **Delivery Methods and Schedule**

A variety of delivery methods will be used to reach each audience over the course of the permit period. Each year, working through the NSP Outreach Committee, the NSP will develop an annual work plan that specifies the final mix of activities that will be implemented that year. Each year's work plan will be revised or adjusted in response to the ongoing evaluation activities. The sections below outline the delivery methods that will be utilized, at a minimum, to reach each of the target audiences and the expected timing of each method.

### Residential Audiences

- Develop and maintain a comprehensive regional stormwater website that covers key messages for the residential audience and maintain a prominent link to the site on the Town's homepage and or DPW homepage.
- Establish a regional stormwater telephone hotline and web form through which members of the public can report stormwater problems or ask questions.
- Inclusion of pet waste management information annually when completed dog licenses or renewal confirmations are mailed out by town clerks.
- Three annual messages (spring, summer and fall) covering grass clippings/fertilizer, pet waste, and leaf disposal distributed via a mixture of direct mailings, social media posts, town newsletters, bill stuffers, press releases, email marketing or signage campaigns.
- Distribution of at least two additional messages over the permit term via direct mail, social media, town newsletters, bill stuffers, press releases, email marketing or signage campaigns.
- One targeted mailing to septic system owners during the permit term.
- Deliver one to two hour 5<sup>th</sup> Grade interactive stormwater education classroom programs to all classes annually including take-home information.
- The Town may use an alternate delivery method for one or more of the messages outlined above where such alternate format is deemed more effective.

### Businesses, Institutions and Commercial Facilities

- Develop and maintain a comprehensive regional stormwater website that covers key messages for the residential audience and maintain a prominent link to the site on the Town's homepage and or DPW homepage.
- Establish a regional stormwater telephone hotline and web form through which members of the public can report stormwater problems or ask questions.
- Two annual messages (spring and fall) covering grass clippings/fertilizer and leaf disposal distributed via a mixture of direct mailings, social media posts, town newsletters, bill stuffers, press releases, email marketing or signage campaigns.

- Distribution of at least two additional messages over the permit term via direct mail, social media, town newsletters, bill stuffers, press releases, email marketing, presentations to industry groups or signage campaigns.
- One targeted mailing to septic system owners (if any) during the permit term.
- A pilot project targeting the ten largest private impervious cover owners with a program of direct outreach via phone, personal mail and/or face to face to and based on the status of compliance with O&M requirements in local permits.
- Free technical assistance and property evaluation for green infrastructure retrofits.
- Distribute educational materials and/or signage that businesses can use to educate their employees and/or customers.
- The Town may use an alternate delivery method for one or more of the messages outlined above where such alternate format is deemed more effective.

### Development and Construction Sectors

- Develop and maintain a comprehensive regional stormwater website that covers key messages for the Development/Construction audience and a prominent link to the Development/Construction section of the educational website will be placed on the on the town website where stormwater and/or wetland permit application forms can be downloaded.
- Establish a regional stormwater telephone hotline and web form through which members of the public can report stormwater problems or ask questions.
- Two messages distributed to a targeted list of local developers / and construction industry representatives via printed materials, mailings, presentations to industry groups, or personal communication that emphasize sediment and erosion control, changes to the Town's stormwater bylaw, anticipated changes to the MA Stormwater Handbook and/or the EPA Construction General Permit.
- The Town may use an alternate delivery method for one or more of the messages outlined above where such alternate format is deemed more effective.

### Industrial Facilities

- Develop and maintain a comprehensive regional stormwater website that covers key messages for the Industrial audience.
- Establish a regional stormwater telephone hotline and web form through which members of the public can report stormwater problems or ask questions.
- Distribution of at least two additional messages over the permit term via direct mail, social media, town newsletters, bill stuffers, press releases, email marketing, presentations to industry groups, or signage campaigns.
- One targeted mailing to septic system owners (if any) during the permit term.

- A pilot project targeting the key large private impervious cover owners with a program of direct outreach via phone, personal mail and/or face to face to and/or based on status of compliance with O&M requirements in local permits or EPA MSGP.
- Free technical assistance and property evaluation for green infrastructure retrofits.
- Distribute educational materials and/or signage that industrial firms can use to educate their employees and/or customers.
- The Town may use an alternate delivery method for one or more of the messages outlined above where such alternate format is deemed more effective.



**Preliminary Summary of Outreach and Education BMPs by Audience and Year**

<b>Audience</b>	<b>YR 1 (2018-2019)</b>	<b>YR 2 (2019-2020)</b>	<b>YR 3 (2020-2021)</b>	<b>YR 4 (2021-2022)</b>	<b>YR 5 (2022-2023)</b>
<b>Residential</b>	<ul style="list-style-type: none"> <li>• Implement school outreach program (for opt-in communities)</li> <li>• Fall leaf litter outreach Dog license renewal outreach</li> <li>• Spring fertilizer outreach</li> <li>• Summer dog waste outreach</li> <li>• Educational website</li> <li>• Stormwater hotline</li> </ul>	<ul style="list-style-type: none"> <li>• MCM message to residential audience</li> <li>• Assemble contact info for septic system owners</li> <li>• Implement school outreach program (for opt-in communities)</li> <li>• Fall leaf litter outreach</li> <li>• Dog license renewal outreach</li> <li>• Spring fertilizer outreach</li> <li>• Summer dog waste outreach</li> <li>• Educational website</li> <li>• Stormwater hotline</li> </ul>	<ul style="list-style-type: none"> <li>• Targeted message to septic system owners</li> <li>• Implement school outreach program (for opt-in communities)</li> <li>• Fall leaf litter outreach</li> <li>• Dog license renewal outreach</li> <li>• Spring fertilizer outreach</li> <li>• Summer dog waste outreach</li> <li>• Educational website</li> <li>• Stormwater hotline</li> </ul>	<ul style="list-style-type: none"> <li>• MCM message to residential audience</li> <li>• Implement school outreach program (for opt-in communities)</li> <li>• Fall leaf litter outreach</li> <li>• Dog license renewal outreach</li> <li>• Spring fertilizer outreach</li> <li>• Summer dog waste outreach</li> <li>• Educational website</li> <li>• Stormwater hotline</li> </ul>	<ul style="list-style-type: none"> <li>• Implement school outreach program (for opt-in communities)</li> <li>• Fall leaf litter outreach</li> <li>• Dog license renewal outreach</li> <li>• Spring fertilizer outreach</li> <li>• Summer dog waste outreach</li> <li>• Educational website</li> <li>• Stormwater hotline</li> </ul>
<b>Business/ Industry/ Commercial Facilities</b>	<ul style="list-style-type: none"> <li>• Begin identifying 10 key private impervious owners per town and O&amp;M plan status</li> <li>• Fall leaf litter outreach</li> <li>• Spring fertilizer outreach</li> <li>• Educational website</li> <li>• Stormwater hotline</li> <li>• Green infrastructure tech. assist. on request</li> </ul>	<ul style="list-style-type: none"> <li>• Pilot project to contact largest private impervious owners</li> <li>• Assemble contact info for septic system owners</li> <li>• Fall leaf litter outreach</li> <li>• Spring fertilizer outreach</li> <li>• Educational website</li> <li>• Stormwater hotline</li> <li>• Green infrastructure tech. assist. on request</li> </ul>	<ul style="list-style-type: none"> <li>• Targeted message to septic system owners</li> <li>• Fall leaf litter outreach</li> <li>• Spring fertilizer outreach</li> <li>• Educational website</li> <li>• Stormwater hotline</li> <li>• Green infrastructure tech. assist. on request</li> </ul>	<ul style="list-style-type: none"> <li>• MCM message to business audience</li> <li>• Fall leaf litter outreach</li> <li>• Spring fertilizer outreach</li> <li>• Educational website</li> <li>• Stormwater hotline</li> <li>• Green infrastructure tech. assist. on request</li> </ul>	<ul style="list-style-type: none"> <li>• Fall leaf litter outreach</li> <li>• Spring fertilizer outreach</li> <li>• Educational website</li> <li>• Stormwater hotline</li> <li>• Green infrastructure tech. assist. on request</li> </ul>
<b>Developer/ Construction</b>	<ul style="list-style-type: none"> <li>• Begin identifying key members of developer / construction industry in each community</li> </ul>	<ul style="list-style-type: none"> <li>• Prepare and distribute information on new bylaws / stormwater standards, and low impact development</li> </ul>	-	-	<ul style="list-style-type: none"> <li>• Distribute information on erosion and sediment control and EPA construction general permit</li> </ul>
<b>Industrial facilities</b>	<ul style="list-style-type: none"> <li>• Educational website</li> <li>• Stormwater hotline</li> <li>• Green infrastructure tech. assist. on request</li> </ul>	<ul style="list-style-type: none"> <li>• Begin developing list of key industrial property owners</li> <li>• Assemble contact info for septic system owners</li> <li>• Educational website</li> <li>• Stormwater hotline</li> <li>• Green infrastructure tech. assist. on request</li> </ul>	<ul style="list-style-type: none"> <li>• Contact key industrial property owners regarding outdoor maintenance practices</li> <li>• Targeted message to septic system owners</li> <li>• Educational website</li> <li>• Stormwater hotline</li> <li>• Green infrastructure tech. assist. on request</li> </ul>	<ul style="list-style-type: none"> <li>• Educational website</li> <li>• Stormwater hotline</li> <li>• Green infrastructure tech. assist. on request</li> </ul>	<ul style="list-style-type: none"> <li>• Contact key industrial property owners regarding outdoor maintenance practices Educational website Stormwater hotline Green infrastructure tech. assist. on request</li> </ul>

## **Evaluation and Adaptive Management**

The MS4 Permit requires that the Town conduct an ongoing process of evaluation on its outreach and education program to demonstrate:

- evidence of focused messages for specific audiences
- evidence that progress toward the educational goals has been achieved

The NSP will use the following methods to evaluate the effectiveness of its educational messages and its program overall:

- Track the number of messages delivered (pieces of material mailed, pieces of material handed out, press releases published and circulation, phone contacts where target is reached, classroom programs delivered, etc).
- Track the number of hits on the stormwater web site over time and in the period following distribution of each message.
- Track number of inquiries to the stormwater hotline via phone call or web submission.
- Track number of “shares” or “likes” on social media such as Facebook or Twitter.
- Track anecdotal feedback from classroom teachers whose students receive the school outreach program.
- Note any anecdotal feedback or observations of behavior change.
- If resources allow, the NSP may also conduct targeted public surveys using an online survey panel or other means.

If the evaluation program determines that any messages or distribution methods are ineffective, those messages and/or distribution methods shall be modified when the annual Outreach and Education work plan is finalized for the subsequent year.

## **Reporting**

The Town will include documentation of its outreach and education program in its annual report to EPA in the format specified in the EPA annual report forms.

The NSP will provide the Town with an annual report on the NSP Outreach and Education program annually. For each year, this will include at a minimum:

- Copies of the messages (if any) distributed to each audience in the Town during the reporting period.
- The method of distribution for each message.
- The measures and/or methods used to assess the effectiveness of the messages.
- The measures and/or methods used to assess the overall effectiveness of the education program.

The Town may include the NSP annual Outreach and Education Program Progress Report, or applicable excerpts from it, in the Town’s annual report to EPA.

## MCM 2: Public Involvement and Participation

Permit Part 2.3.3

### Objectives

The permittee shall provide opportunities to engage the public to participate in the review and implementation of the permittee's SWMP.

Category: Public Participation		Due Yr	Update	Reference / Remarks
2.1	Provide an opportunity to participate in SWMP "review and implementation"	1	annually	See 2.3.3. Must comply with state public notice requirements.
2.2	Annual reports and SWMP available to the public in person and online	1	ongoing	See 2.3.3 and 1.10. Per 4.2.a records not in SWMP and annual reports must also be available to public in person.

### Background and Goals

The Town of Sharon (the Town) will implement a public participation program to complement and reinforce the town's MS4 public outreach program and other SWMP implementation activities.

The goals of the Town's public involvement and participation program are to:

- Provide opportunities for the public to participate in the review and implementation of the Town's SWMP.
- Achieve compliance with public involvement and participation requirements contained in section 2.3.3 of the MS4 permit.
- Increase awareness of the impact of stormwater pollution on water bodies in the Town, especially impaired and priority waters.
- Increase public awareness of the work being done by the Town to maintain and improve stormwater infrastructure, and the economic, recreational, water supply, and ecological benefits of that work.
- Increase awareness of how the public can support and assist the Town in implementing an effective stormwater management program.
- Encourage individuals and organizations to adopt habits and engage in voluntary actions that increase groundwater recharge, decrease pollutant loading, and decrease peak discharge rates, thereby reducing the burden placed on public stormwater infrastructure and the environment.

### Responsible Parties and Regional Implementation Strategy

The Town has joined with its neighboring communities to implement its public education and outreach program on a regional basis through the Neponset Stormwater Partnership (NSP).

One or more designated representatives from the Town participate in the NSP meetings to develop, implement, evaluate and revise its public involvement and participation program. The

NSP Outreach Committee develops a public involvement and participation work plan and budget each year, the implementation of which is funded by the Town in conjunction with other participating communities. The goal of this regional approach is to increase the effectiveness and reduce the cost of the public involvement and participation program, relative to what could be achieved through a program implemented by the Town working on its own.

The Town's stormwater Public Involvement and Participation Coordinator is:

- Town Engineer

Key contacts with the NSP responsible for day to day planning, management and implementation of the NSP Outreach and Education Program include:

- Outreach Director, Neponset River Watershed Association
- Executive Director, Neponset River Watershed Association

The above named individuals are responsible for ensuring that the public involvement and participation program is implemented in accordance with this SWMP.

### **Public Involvement and Participation Requirements**

The MS4 Permit requires that the Town:

- Make the SWMP and all annual reports available to the public.
- Annually provide the public an opportunity to participate in the review and implementation of the SWMP.
- Ensure that all public involvement and participation activities be posted in accordance with state public notice requirements (MGL Chapter 30A, Sections 18 – 25 – effective 7/10/2010).

### **Public Involvement and Participation Activities**

The Town's public involvement and participation program shall consist of the following activities:

Activities implemented by the Town's Public Participation and Involvement Coordinator:

- Promptly post the SWMP (and any future revisions to the SWMP) including the Town's annual reports on the Town website.
- Post a legal notice once per year inviting the public to review and submit comments on the SWMP in accordance with state public notice requirements.
- Allow the public to inspect the SWMP in person during regular business hours.
- Annually compile any comments received on the SWMP along with the corresponding response from the Town (if any).
- Post a link on the Town's website to the public participation area of the regional website.

Activities implemented by the NSP on behalf of the town

- Establish a regional stormwater telephone hotline and web form through which members of the public can report stormwater problems or ask questions.
- Invite volunteers to install storm drain markers and other educational signage.

- Invite businesses to install or circulate materials to educate their customers and/or employees about preventing stormwater pollution.
- Other participation activities that may be identified as circumstances arise.

### **Reporting and Evaluation**

The Town will include documentation of its public involvement and participation program in its annual report to EPA in the format specified in the EPA annual report forms. For each year, this will include a listing of public participation activities implemented by the Town during the year.

The NSP will provide the Town with an annual report on the NSP Public Participation Program annually. For each year, this will include at a minimum dates and a brief description of activities implemented through the year, along with a qualitative evaluation of the effectiveness of those public participation activities. Where any activities are judged to be ineffective, the NSP Public Participation Program will be modified accordingly for the subsequent year.

The Town may include the NSP annual Public Participation Program Progress Report, or applicable excerpts from it, in the Town's annual report to EPA.

## MCM 3: Illicit Discharge Detection and Elimination (IDDE) Program

### Permit Part 2.3.4

#### Objectives

The permittee shall implement an IDDE program to systematically find and eliminate illicit sources of non-stormwater discharges to its municipal separate storm sewer system and implement procedures to prevent such discharges.

Category: Illicit Discharge Detection and Elimination		Due Yr	Update	Reference
3.1	Bylaw prohibiting illicit discharges and authorizing investigation, repair and enforcement	0	none	See 2.3.4.a.
3.2	Notify EPA / DEP of SSO orally in 24hrs and in writing in 5 days	1	ongoing	See 2.3.4.4
3.3	Notify responsible party immediately on id of illicit discharge	1	ongoing	See 2.3.4.2
3.4	Eliminate known illicit or set expeditious schedule in 60 days	1	ongoing	See 2.3.4.2
3.5	Report on all known SSOs in last five years	1	annually	See 2.3.4.4
3.6	Initial outfall / interconnection inventory and ranking	1	annually	See 2.3.4.7.
3.7	Written outfall screening and sampling procedure	1	none	See 2.3.4.7.b
3.75	Written IDDE Program document	1	annually	See 2.3.4.6
3.8	Annually train IDDE staff	1	annually	See 2.3.4.11
3.9	Confirmatory outfall or interconnection screening during dry and/or wet weather after removal of an illicit connection	1	ongoing	See 2.3.4.8.e.
3.10	Written catchment investigation procedure	2	none	See 2.3.4.8
3.11	Finish "Phase I" system mapping requirements	2	none	See 2.3.4.5.a
3.12	Investigation of problem catchments must begin	2	none	See 2.3.4.8
3.13	Update system map with available "Phase II" information	3	annually	See 2.3.4.5.b.
3.15	Dry weather outfall and interconnection screening	3	see below	See 2.3.4.7.b.
3.16	Follow up outfall and interconnection ranking	3	annually	See 2.3.4.7.c.
3.17	Complete investigation of problem and sewer input indicator catchments	7	none	See 2.3.4.8.
3.18	Investigation of all other catchments completed	10	none	See 2.3.4.8.
3.19	Revisit outfall screening every five years after completion of all catchment investigations	15	every 5 years	See 2.3.4.10.

## Introduction and Purpose of Program

The municipal separate storm sewer system (MS4) permit issued by the Environmental Protection Agency (EPA) to the Town of Foxborough (hereafter “the Town”) requires the implementation of an Illicit Discharge Detection and Elimination (IDDE) Program to systematically find and eliminate non-stormwater discharges to the MS4 and to prevent the introduction of new illicit connections and discharges.

This document describes the Town’s IDDE Program in detail and constitutes the “Written IDDE Program Document” required by the permit. This document was prepared based on a model provided by the Neponset Stormwater Partnership and funded in part through a Community Innovation Challenge Grant. The procedures outlined here were adapted from guidance documents by the Central Massachusetts Regional Stormwater Coalition, the Center for Watershed Protection, New England Interstate Water Pollution Control Commission, Massachusetts Department of Environmental Protection, US Environmental Protection Agency, the Boston Water and Sewer Commission, the New Hampshire Estuaries Project, and the Neponset River Watershed Association’s water quality monitoring program.

This document will be reviewed and updated on a periodic basis to reflect changes to the Town’s IDDE Program. The Town is required to submit an annual report each year of the permit term. Table 6 provides a summary of annual reporting requirements for the IDDE Program.

## Acronyms and Definitions

**Catchment** – A catchment is the area of land that drains to an individual outfall or interconnection. Each Catchment has only one outfall, and each outfall has only one catchment.

**CSO** – Combined Sewer Overflow.

**EPA** – US Environmental Protection Agency.

**IDDE** – Illicit Discharge Detection and Elimination.

**Illicit Connection** – An illicit connection is any connection to the MS4 that is not authorized and is causing or contributing to an illicit discharge.

**Illicit Discharge** – An illicit discharge is any discharge of pollutants to the MS4 other than rain runoff or clean groundwater, examples include sewer-drain cross connections; seepage of septic system effluent or exfiltrate from a damaged sewer into a drain; sanitary sewer overflow; dumping or washing of pollutants into a catch basin such as oil, litter or pet waste; dumping of pollutants into a waterway or wetland such as yard waste; discharge from floor drains; or discharge of contaminated sump pump effluent. However, illicit discharges exclude discharges authorized under a separate NPDES permit and the following allowable non-stormwater discharges: water line flushing, landscape irrigation, diverted stream flows, rising groundwater, uncontaminated ground water infiltration, uncontaminated pumped ground water, discharge from potable water sources, foundation drains, air conditioning condensate, irrigation water, springs, uncontaminated water from crawl space pumps, footing drains, individual resident car washing, flows from riparian habitats and wetlands, dechlorinated swimming pool discharges, street wash waters, residential building wash waters without detergents, and flows from firefighting activities, unless the Town, EPA or MassDEP identifies any of these as a significant contributor of pollutants to the MS4, in which case it will be addressed as an illicit discharge.

**Interconnection** – Any point in the Town’s MS4 system that discharges to another MS4 or other stormwater system not owned and operated by the Town, or where a drainage collection system owned by an entity other than the Town connects to the Town’s MS4 infrastructure. Interconnections where an

outside system discharges to the Town system may be referred to as incoming interconnections, and where the Town system discharges to an outside system it is referred to as outgoing interconnections.

**MassDEP** – Massachusetts Department of Environmental Protection.

**MS4** – The Municipal Separate Storm Sewer System owned and operated by the Town.

**MS4 Permit** – The 2016 NPDES Phase II Municipal Separate Storm Sewer System Permit which took effect in July 1 2018 as issued by EPA to the Town.

**NPDES** – National Pollutant Discharge Elimination System: A permit to discharge pollutants to a waterbody under the federal Clean Water Act.

**NSP** – The Neponset Stormwater Partnership. A regional collaboration of cities and towns who are cooperating on MS4 implementation activities.

**Outfall** – The end point of a storm drain collection system (pipe network, ditch, paved waterway, erosion channel, etc) where stormwater is discharged to a waterway or wetland (i.e. waters of the US). Refer also to “Cooke, Ian and Tedder, Newton Email Correspondence” under References below for further details. A point at which a closed pipe discharges to an open MS4 conveyance or an open structural BMP (i.e. closed pipe enters a detention basin or closed pipe enters a surface ditch) is not considered an outfall. In such cases the outfall is the point where the detention basin or ditch, or any closed piping downstream of them discharges to the environment. Similarly, the inlet and outlet of simple road culverts that convey a waterway under a road are not considered outfalls, though in many cases there are outfalls that discharge to waters of the US inside road crossing culverts. Throughout this document, the term “outfall” is used interchangeably to mean “outfall or outgoing interconnection.”

**SSO** – Sanitary Sewer Overflow: An overflow of untreated sanitary wastewater from a municipal sanitary sewer to a waterbody, a storm drain collection system, roadway or inside a building.

**SWMP** – Stormwater Management Program: A written document describing the Town’s program to comply with the MS4 Permit requirements.

**TMDL** – Total Maximum Daily Load: A cleanup plan for a specific pollutant that is causing a violation of water quality standards in a particular waterbody.

## **Legal Authority**

Through its stormwater bylaw (Foxborough Codification Chapter 232) and associated regulation, the Town has established the legal authority to:

- prohibit illicit discharges and Sanitary Sewer Overflows (SSOs) into the MS4 system
- investigate suspected illicit discharges
- eliminate illicit discharges, including discharges from properties not owned by or controlled by the town that discharge into the MS4 system, and
- implement appropriate enforcement procedures and actions

A copy of the Town’s bylaw or regulation is included as an attachment to this document as indicated in on the Town Website.



## Statement of IDDE Responsibilities

The Town's Stormwater Bylaw empowers the Planning Board to enforce the IDDE provisions of the Bylaw. The Planning Board has delegated day to day management, operation and reporting to the Foxborough Town Engineer. There is also coordination required with other departments to make the program successful.

The Planning Board is responsible for coordinating the efforts of other departments when needed, ensuring that necessary interdepartmental communication occurs in a timely manner, and following up with other departments as needed regarding the status of their efforts.

Key contacts and roles for each of the other departments are as follows:

**Table 1: IDDE Roles and Responsible Parties**

<b>IDDE Implementation Role</b>	<b>Responsible Authority/Individual</b>
IDDE enforcement authority under Stormwater Bylaw	Foxborough Planning Board
Overall Supervision of IDDE Program	DPW Director
Day to Day Supervision of IDDE Program and Reporting	Town Engineer
Enforcement authority for SSOs	Board of W/S Chair
Enforcement authority for Septic Systems and Septic System Construction	Health Director
Enforcement of State Plumbing Code	Building Commissioner
Enforcement Actions	Town Legal Counsel
Person(s) Responsible for Recordkeeping	Town Engineer

## Required Schedule

The MS4 permit defines the required timeline for major tasks in implementing the Town's IDDE program as summarized in Table 2 below.

**Table 2: IDDE Program Required Schedule**

IDDE Task	Permit Schedule
<b>General</b>	
Establish Adequate Legal Authority Over MS4	Due May 1, 2002
Written IDDE Program	Year 1 (June 30, 2019)
Eliminate Illicit Discharges or Make an Expeditious Plan for Elimination	Within 60 days of discovery
Training for all IDDE Staff	Annually
Tracking and Reporting IDDE Progress	Annually
<b>SSO Inventory and Reporting</b>	
Inventory of all SSO's that Occurred Over the Previous 5 years	Year 1 (June 30, 2019) and updated annually
Oral Notification to EPA and DEP of an SSO	24 hours from discovery
Written Notification to EPA and DEP of an SSO	5 days from discovery
<b>System Mapping</b>	
Phase 1 of System Mapping	Year 2 (June 30, 2020)
Phase 2 of System Mapping	Year 10 (June 30, 2028)
<b>Outfall and Interconnection Screening</b>	
Written Outfall and Interconnection Screening Procedure	Year 1 (June 30, 2019)
Initial Outfall and Interconnection Inventory and Ranking	Year 1 (June 30, 2019) and updated annually
Updated Outfall and Interconnection Ranking	Year 3 (June 30, 2021)
All Outfalls (High and Low Priority) Inspected During Dry Weather	Year 3 (June 30, 2021)
Revisit Outfalls With Evidence of Illicit Discharge but No Flow	Within 1 week of initial inspection
Confirmatory Outfall and Interconnection	Within 1 year of Illicit Discharge Removal
<b>Catchment Investigations</b>	
Written Catchment Investigation Procedure	18 Months (December 31, 2019)
Begin Investigations for All Catchments Related to Problem Outfalls	Year 2 (June 30, 2020)
Complete Investigations of All Catchments Related to Problem Outfalls	Year 7 (June 30, 2025)
Complete All Catchment Investigations	Year 10 (June 30, 2028)

## Sanitary Sewer Overflows

Action will be taken to eliminate all dry weather and wet weather Sanitary Sewer Overflows (SSOs) immediately upon discovery. If the SSO cannot be eliminated immediately, interim mitigation measures to minimize the discharge of pollutants to the MS4 and/or the environment will be taken, and elimination will be completed as soon as possible.

EPA and MassDEP will be notified of all SSOs by telephone or in writing as soon as possible once the Town becomes aware that an SSO has occurred and, at a minimum, within 24 hours of discovery. In addition, immediate notification may be needed to the local Board of Health (see Table 1), to any affected downstream water supply or swimming/recreation area operators, or via the MassDEP 24 hour hotline when hazardous waste or oil may be involved.

MassDEP 24 hour Hotline: 1-888-304-1133

Written notice of all SSOs will be provided to EPA and MassDEP within 5 days of discovery using the required MassDEP reporting form. Copies of the written report will be forwarded to other relevant parties as indicated on the MassDEP form. Copies of written reports are maintained on file.

The Town also maintains an inventory of all dry weather and wet weather SSOs as a part of this program. An inventory of all SSOs that occurred within 5 years prior to the effective date of the permit will be prepared within the first year of the MS4 Permit and will be updated at least annually as part of the annual report. The inventory is maintained in the Town's excel spreadsheet on the network drive. The following information is collected and logged:

- Location (approximate address or intersection and receiving waterbody, if any);
- Clear statement of whether the discharge entered a surface water or storm drain;
- Start and end dates and times of SSO;
- Estimated approximate volume of the overflow;
- Description including known or suspected cause;
- Mitigation and corrective measures planned with implementation schedules;
- Date and description of mitigation and corrective actions taken;
- Current status of mitigation and corrective measures; and
- Copy of completed 5 day written report and documentation (if any) of 24 hour report (where available for older incidents).

A copy of the Town's SSO inventory is located in Appendix F.

## System Mapping

The Town will complete more detailed mapping of its stormwater infrastructure in two phases. Phase one mapping will be completed within two years of the permit effective dates (June 30, 2020), and phase two will be completed within 10 years (June 30, 2028). Recommended mapping elements will be completed as resources allow. Mapping will be prepared using ArcGIS. Storm system mapping will serve as a critical planning tool for the implementation of the IDDE program. The Town will update and correct the mapping on an ongoing basis as new information becomes available and a status report on the mapping effort will be included with each annual report.

In addition to piped outfalls, the Town will also map "discrete conveyances" such as paved waterways discharging to waters of the US, and curb cuts that discharge to waters of the US without a paved

waterway such as via an erosion channel (see "Cooke, Ian and Tedder, Newton Email Correspondence" under References below for further details).

Where resources allow, the Town may also map privately owned outfalls or incoming interconnections that it encounters during its field investigations as a means to validate that all Town-owned outfalls have been mapped and to avoid confusion on the part of field crews and to clarify responsibility and facilitate rapid correction in the event of any future pollution discharge incidents.

**Phase 1:** the following elements have been or will be mapped within two years of the permit effective date (6/30/20):

- Outfalls and receiving waters;
- Open channel conveyances (swales, ditches, paved waterways etc.);
- Interconnections with other MS4's and other storm drain systems;
- Municipally-owned stormwater treatment structures (e.g., detention and retention basins, infiltration systems, bioretention areas, rain gardens, tree filters, water quality swales, gross particle separators, oil/water separators, or other proprietary systems);
- Waterbodies identified by name and indication of all use impairments as identified on the most recent EPA approved MassDEP Integrated List of waters report pursuant to Clean Water Act section 303(d) and 305(b); and
- Initial catchment delineations. Any available system data and topographic information may be used to produce initial catchment delineations. For the purpose of this permit, a catchment is the area that drains to an individual outfall or outgoing interconnection.

**Phase 2:** Phase 2 system mapping shall be updated annually as new information becomes available during the implementation of catchment investigations. Phase 2 mapping will be completed by year 10 and will include:

- Outfall spatial location (latitude and longitude with a minimum accuracy of +/- 30 feet);
- Pipes;
- Manholes;
- Catch basins;
- Refined catchment delineations. Catchment delineations shall be updated to reflect information collected during catchment investigations;
- Municipal sanitary sewer system (if applicable); and
- Municipal combined sewer system (if applicable).

In addition to the above required elements, the following recommended elements will be incorporated into the Town's system mapping as funding and staffing allow:

- Storm sewer material, size and age;
- Sanitary sewer system material, size and age;
- Privately-owned stormwater treatment structures;
- Where a municipal sanitary sewer system exists, properties known or suspected to be served by a septic system or other onsite wastewater management facility, especially in high-density urban areas;
- Areas where the MS4 has been or could be influenced by septic system discharges (e.g., areas with poor soils, or high ground water elevations unsuitable for conventional subsurface disposal systems near water bodies);
- Seasonal high water table elevations impacting sanitary alignments;
- Topography;

- Orthophotography;
- Alignments, dates and representation of work completed (with legend) of past illicit discharge investigations (e.g., flow isolation, dye testing, CCTV); and
- Locations of suspected, confirmed and corrected illicit discharges (with dates and flow estimates).

## **Assessment and Initial Ranking of Outfalls and Interconnections**

The Town has mapped its MS4 outfalls and interconnections (incoming and outgoing) to other stormwater systems and has defined the preliminary boundaries of the catchment for each outfall or outgoing interconnection. Preliminary catchment delineations were developed using the Metropolitan Area Planning Council (MAPC) Catchment Delineation Procedure.

By the close of permit year 1, the NSP IDDE Prioritization Tool will be used to synthesize the GIS data provided by MAPC along with ambient water quality data and impaired waters data provided by the Neponset River Watershed Association (NepRWA), MassDEP, along with local knowledge provided by the Town as detailed in the NSP IDDE Prioritization Tool.

Each of the outfalls and outgoing interconnections will be placed into one of the following categories based on available data and the weighting system built into the NSP IDDE Prioritization Tool:

*Not Owned by Town* – Outfalls or incoming interconnections which are not owned by the Town, but which have been mapped to validate the completeness of the outfall inventory and facilitate clear communication of responsibility and effective response in the event of any future discharges. These outfalls do not need to undergo outfall screening nor catchment investigation.

*Not Waters of the US* – Outfalls which are owned by the Town, but which do not discharge to waters of the US, are not subject to the requirements of the MS4 Permit. These outfalls will be tracked in the Town’s outfall inventory for consistency, but do not need to undergo outfall screening, or catchment investigation.

*Excluded* – Excluded outfalls and outgoing interconnections are those that have no potential for illicit discharges. They are located in undeveloped areas with no dwellings and no sanitary sewers; or serve drainage for athletic fields, parks, or undeveloped green space or associated parking without services; or are cross-country drainage alignments (that neither cross nor are in proximity to sanitary sewer alignments) through undeveloped land.

*Problem* – Problem outfalls and outgoing interconnections are those with known or suspected illicit discharges due to past credible complaints, departmental knowledge or previous screening. Problem outfalls may bypass the screening process and proceed directly to catchment investigation.

*High Priority* – High priority outfalls and outgoing interconnections are those that discharge to areas of concern to public health such as beaches, recreational areas, drinking water supplies or shellfish beds. They also include outfalls with catchments determined to have a high potential for sewage input based on outfall/interconnection screening results and catchment characteristics.

*Low Priority* – Low priority outfalls and outgoing interconnections include those that have been determined to have a low potential for sewage input based on outfall/interconnection screening results and catchment characteristics.

The Town's ranking process as captured by the NSP IDDE Prioritization Tool considers the following factors when ranking outfalls into and within the categories of problem, high priority and low priority, as required by the MS4 permit:

- Past discharge complaints and reports.
- Poor receiving water quality – the following guidelines are recommended to identify waters as having a high illicit discharge potential: exceeding water quality standards for bacteria; ammonia levels above 0.5 mg/l; surfactants levels greater than or equal to 0.25 mg/l.
- Density of generating sites – Generating sites are those places, including institutional, municipal, commercial, or industrial sites, with a potential to generate pollutants that could contribute to illicit discharges. Examples of these sites include, but are not limited to, car dealers; car washes; gas stations; garden centers; and industrial manufacturing areas.
- Age of development and infrastructure – Industrial areas greater than 40 years old and areas where the sanitary sewer system is more than 40 years old will probably have a high illicit discharge potential. Developments 20 years or younger will probably have a low illicit discharge potential.
- Sewer conversion – contributing catchment areas that were once serviced by septic systems, but have been converted to sewer connections may have a high illicit discharge potential.
- Historic combined sewer systems – contributing areas that were once serviced by a combined sewer system, but have been separated may have a high illicit discharge potential.
- Surrounding density of aging septic systems – Septic systems thirty years or older in residential land use areas are prone to have failures and may have a high illicit discharge potential.
- Culverted streams – any river or stream that is culverted for distances greater than a simple roadway crossing may have a high illicit discharge potential.
- Water quality limited waterbodies that receive a discharge from the MS4 or waters with approved TMDLs applicable to the permittee, where illicit discharges have the potential to contain the pollutant identified as the cause of the water quality impairment.

In order to conduct outfall screening in an efficient manner, the Town may choose to dry weather screen all outfalls along a given stream segment as a group. This will allow personnel to move quickly down the length of a single stream, and to collect a group of outfall screening samples that need to be tested for the same parameters based on stream impairments.

If so, in order to determine which stream segments will have their outfalls screened first, all outfalls (except excluded, not waters of the US and not owned by town) are initially ranked individually as problem, high, and low using the NSP IDDE Prioritization Tool. The outfalls are then sorted by MassDEP stream segment (assessment unit). Streams with the highest number of outfalls rated as “high priority” will be screened first as detailed in the NSP IDDE Prioritization Tool.

The outfall inventory and ranking will be updated on an ongoing basis and at least annually as work on the IDDE program proceeds. The updated inventory and ranking will be included with each year's annual report.

### **Dry Weather Outfall and Interconnection Screening and Sampling**

Dry weather screening/sampling will be conducted at each of the Town's outfalls and at any outgoing interconnections with other stormwater systems, except for problem, excluded, not waters of the US, and not Town owned outfalls. The dry weather screening consists of a series of qualitative field observations along with field and/or lab analysis of selected water quality parameters where outfalls are discharging

during dry weather. As described above, in the interest of efficiency, dry weather screening will be completed for an entire waterbody or stream segment at once in the order established during the initial outfall ranking described above. Dry weather outfall screening will be completed by the end of permit year three, and copies of all screening data collected through the program will be included with each annual report.

### **Weather and Scheduling**

Dry weather outfall / interconnection screening will take place only when less than 0.1 inches of rainfall has occurred in the previous 24-hr period and no snow melt is occurring. However, where possible, dry weather screening will occur after 48-72 hours with no precipitation or runoff. Weather conditions will be monitored using data available from the Blue Hills or Norwood Airport weather station or a combination of both.

Scheduling will also be based on the availability of laboratory services. In particular E.coli samples must be delivered to the lab within six hours, and the lab analysis must be completed by reading the samples 24 hours after testing has begun. Thus, in most cases sampling will take place in the morning so that samples can be processed by the lab in the afternoon, and sampling will take place Monday through Thursday unless the selected lab is open on Saturday.

Where feasible, dry weather screening will be completed in the spring and early summer (March through June) to help ensure that smaller illicit discharges that might not reach the outfall during drought periods are also identified.

### **Field Data Collection**

When performing dry weather screening in the field, the Town's outfall screening procedure is followed and a paper or digital outfall inspection form is filled out in the field. See Appendix E for the relevant forms and procedures. The following data is captured at a minimum for each outfall and interconnection:

- Unique Identifier Outfall ID;
- Receiving water;
- Date of most recent inspection;
- Dimensions;
- Shape;
- Material;
- Spatial location (GPS coordinates);
- Physical condition; and
- indicators of potential non-stormwater discharges, including presence or evidence of suspect flow and sensory observations such as odor, color, turbidity, floatables, or oil sheen;

If flow is observed at the outfall or interconnection manhole during dry weather screening, a sample is taken for analysis as further described under "Outfall / Interconnection Sample Analysis" below. Submerged or inaccessible outfalls will be sampled from the first accessible upstream manhole or access structure and the actual location of sampling will be noted.

If no flow is observed, but there is evidence of illicit dry weather flow such as toilet paper, soap bubbles, fine gray residue, excessive algae on the outfall or odors of sewage or soap, the outfall will be visited again during dry weather within one week of the initial investigation (weather permitting) and sampled if found to be flowing. If the outfall continues to be suspected of containing illicit discharges in spite of a lack of

flow during dry weather visits, alternative testing procedures such as multi-day optical brightener collection may be deployed, or the outfall will be ranked in the high priority category for catchment investigation.

If in the course of conducting dry weather screening additional Town-owned outfalls are encountered, such as non-piped discrete conveyances, paved waterways and stormwater erosion channels, the Town's mapping and outfall inventory will be updated to include these outfalls and they will be screened.

While not required to do so by the MS4 permit, the Town may elect to inspect privately owned outfalls which it encounters during the dry weather screening process, and if found to be flowing during dry weather, may elect to sample such private outfalls for some or all of the water quality indicators as described below. To the extent that a discharge from a non-Town outfall may be causing or contributing to a violation of water quality standards, it will reduce the Town's overall MS4 compliance burden to have that discharge eliminated. Any such non-Town outfalls that appear to be affected by illicit discharges will be referred to the appropriate authorities for resolution.

### **Outfall / Interconnection Sample Analysis**

All samples taken during outfall/interconnection screening are analyzed for the basic screening indicators of temperature, conductivity, salinity, ammonia, chlorine, surfactants, and bacteria. Temperature is measured directly in the field. Conductivity and salinity are measured using a meter OR sent to a lab for analysis. Ammonia, chlorine and surfactants are measured in-house using a portable photometer and appropriate reagents OR sent to a lab. Bacteria samples are sent to a lab for analysis. Specific instruments, hold times, and preservation methods used for the basic screening samples are described in Table 3 below.

All samples, not measured or analyzed directly in the field, will be immediately preserved in ice following sample collection and labeling. All screening samples are securely packed in a cooler with plenty of ice with sufficient cooler space and ice coverage. Sample bottle care, such as firmly sealing bottles and/or placing foam sleeves between bottles, will be maintained during transport of the sample bottles. In addition, when performing screening on a waterway which is impaired for one or more pollutants other than the basic screening parameters or which has is subject to a final TMDL, additional samples are collected as indicated in Appendix G of the MS4 permit. The impairment causes and associated additional required testing parameters that may apply to the Town are summarized in Table 4 below. Table 4 also lists impairment causes that may apply to the Town but for which no additional testing is required. Table 4 has been adapted from Appendix G of the MS4 Permit.

Note that in many areas, the Town may have outfalls that discharge to a wetland or waterway that is not identified as a stream segment or assessment unit by MassDEP. These are often smaller tributaries to the stream segment that is identified by MassDEP. Impaired waters samples are *only* collected from outfalls that are discharging directly to a MassDEP mapped stream segment, they are not collected from unmapped segments upstream of an impaired segment (see "Cooke, Ian and Tedder, Newton Email Correspondence" under References below for further details).

If the Town has information from a source other than the MassDEP Integrated List of Waters that indicates that a waterway is impaired for a particular pollutant, even if that waterway is not mapped as a segment by MassDEP, then the additional impaired waters samples will be tested (see "Cooke, Ian and Tedder, Newton Email Correspondence" under References below for further details.).



These additional impaired waters samples and the standard bacteria sample are analyzed using the more rigorous procedures outlined in Appendix G of the MS4 Permit as dictated by [40 CFR §136](#). Table 5 summarizes the required testing methods for the additional testing parameters, as well as sample container, preservation, hold times, and the instruments or laboratories used to test each sample.

When conducting outfall screening, to the extent possible, grab samples are collected and analyzed later at our offices or a lab rather than being processed in the field. In addition, where possible, a single larger sample bottle will be used as a source for multiple test parameters. This ensures efficient use of staff time and prevents the accidental release of potentially hazardous reagents to the environment. For these same safety reasons, the Town may not fully chemically preserve samples in the field (i.e. adding acid to nutrient samples) but rather will deliver them to the lab, on ice, promptly where they will be fully preserved as needed.

**Table 3: Parameters, Instruments, Field Test Kits, and Laboratories for Basic Screening**

Standard Screening Parameter	Target Detection Limit	Container Type & Sample Volume	Preserv	Hold Time	OK to Combine ?	Instrument, Portable Meter, or Lab Name
Ammonia	0.05 mg/L	125-250ml plastic	Ice	Process same day	Yes	<ul style="list-style-type: none"> <li>*Chemetrics V-2000 or V-3000 Multi-Analyte Photometer, with reagents</li> <li>Analytical Balance Corp</li> </ul>
Chlorine	0.02 mg/l	125-250ml plastic	Ice	Process same day	Yes	<ul style="list-style-type: none"> <li>*Chemetrics V-2000 or V-3000 Multi-Analyte Photometer with reagents</li> <li>Analytical Balance Corp</li> </ul>
Conductivity	0.2 mS/cm	500ml plastic	Ice	Process same day	Yes	<ul style="list-style-type: none"> <li>*YSI Pro 30 (temp/ conductivity/ salinity meter)</li> <li>Analytical Balance Corp</li> </ul>
E. coli or Enterococcus	<=4 cfu or mpn	Sterile 125-250ml plastic	Ice	Deliver to lab in 6 hr (process in 8 hours)	No must be sterile	<ul style="list-style-type: none"> <li>Analytical Balance Corp</li> </ul>
Salinity		500ml plastic	Ice	Process same day	Yes	<ul style="list-style-type: none"> <li>*YSI Pro 30 (temp/ conductivity/ salinity meter)</li> <li>Analytical Balance Corp</li> </ul>
Surfactants	0.1 mg/L	125-250ml plastic	Ice	Process same day	Yes	<ul style="list-style-type: none"> <li>*CHEMetrics™ I-2017, single parameter meter with reagents.</li> <li>Analytical Balance Corp</li> </ul>
Temperature	0 to 40 °C	Measure in field	None	Measure in field	n/a measure in field	<ul style="list-style-type: none"> <li>*YSI Pro 30 (temp/ conductivity/ salinity meter)</li> </ul>

**Table 4: Additional Tests Required for Screening Impaired Waters (see Table 5 for test methods)**

<b>"Pollutant" Causing Impairment</b>	<b>Test For</b>
Enterococcus	Enterococcus
Escherichia coli	E. coli
Excess Algal Growth	Total Phosphorus (freshwater)
	Total Nitrogen (marine waters)
Fecal Coliform	Fecal Coliform
Nutrient/Eutrophication Biological Indicators	Total Phosphorus (freshwater)
	Total Nitrogen (marine waters)
Organic Enrichment (Sewage) Biological Indicators	E. coli (freshwater)
	Enterococcus (marine waters)
Oxygen, Dissolved	Dissolved Oxygen
	Temperature
or	BOD5
Dissolved Oxygen Saturation	Total Phosphorus (freshwater)
	Total Nitrogen (marine waters)
pH, High	pH
pH, Low	pH
Phosphorus (Total)	Total Phosphorus
Sedimentation/Siltation	Total Suspended Solids
Total Suspended Solids (TSS)	Total Suspended Solids
Turbidity	Total Suspended Solids
	Turbidity
Aquatic Macroinvertebrate Bioassessments	none required <sup>1</sup>
Aquatic Plants (Macrophytes)	none required
Chlordane	none required
Color	none required
Combined Biota/Habitat Bioassessments	none required <sup>1</sup>
DDT	none required
Debris/Floatables/Trash	none required
Dioxin (including 2,3,7,8-TCDD)	none required
Eurasian Water Milfoil, Myriophyllum spicatum	none required
Fishes Bioassessments	none required <sup>1</sup>
Fish-Passage Barrier	none required
Foam/Flocs/Scum/Oil Slicks	none required <sup>1</sup>
Low flow alterations	none required
Mercury in Fish Tissue	none required
Non-Native Aquatic Plants	none required
Other	none required <sup>1</sup>
Other flow regime alterations	none required
PCB in Fish Tissue	none required
Pentachlorophenol (PCP)	none required
Physical substrate habitat alterations	none required
Polychlorinated biphenyls	none required
Taste and Odor	none required
Temperature, water	none required
<sup>1</sup> Awaiting confirmation from MassDEP as to whether sampling is required	

**Table 5: Test Methods for Additional Impaired Waters Testing**

Impaired Waters Additional Test Parameter	Required Test Method Options <sup>1</sup>	Target Detection Limit	Container Type / Sample Volume <sup>2</sup>	Preserv.	Hold Time <sup>2</sup>	OK to combine tests larger bottle? <sup>2</sup>	Instrument or Lab Name
Enterococcus	1106.1; 1600; Enterolert®	<=4 cfu or mpn	125-250ml sterile plastic with headspace	Ice	Deliver to lab within 6 hr	bacteria samples only	Analytical Balance Corp
E. coli	1103.1; 1603; Colilert®, Colilert-18®; mColiBlue-24®	<=4 cfu or mpn	125-250ml sterile plastic with headspace	Ice	Deliver to lab within 6 hr	bacteria samples only	Analytical Balance Corp
Phosphorus (Total)	365.1; 365.2; 365.3; SM 4500-P	<=10 ug/l	125-250ml plastic	Ice	Deliver to lab same day for preservation with acid <sup>3</sup>	yes	Analytical Balance Corp
Nitrogen (Total)	351.1 or 351.2; <u>and</u> 353.2	<=0.2mg/l	125-250ml plastic	Ice	Deliver to lab same day for preservation with acid <sup>3</sup>	yes	Analytical Balance Corp
Fecal Coliform	1680; 1681	1 CFU	125-250ml sterile plastic with headspace	Ice	Deliver to lab within 6 hr	bacteria samples only	Analytical Balance Corp
Dissolved Oxygen	365.1; 365.2; 365.3 [SM4500-O]	0.5 mg/l	n/a, measure in field	n/a	measure immediately	n/a	Analytical Balance Corp
Temperature	351.1/351.2 + 353.2 [SM2550]	0 to 40 °C	n/a, measure in field	n/a	measure immediately	n/a	*YSI Pro 30 (temp/ conductivity/ salinity meter)
BOD5	360.1; 360.2 [SM5210]	2 mg/l	1L plastic, no headspace or air	Ice	Deliver to lab same day	only those with no headspace	Analytical Balance Corp
pH	150.2	4-10 SU	measure in field or 250ml plastic with no headspace/air	Ice	measure immediately or same day as soon as possible	only those with no headspace	*Extech ExStik pH Meter
Total Suspended Solids	160.2 [SM2540]	<=5 mg/l	1L plastic	Ice	deliver to lab same day	yes	Analytical Balance Corp
Turbidity	180.1	<=.06 NTU	500ml plastic	Ice	deliver to lab same day	yes	Analytical Balance Corp

<sup>1</sup>Information taken from MS4 Permit Appendix G. Note that there appear to be some errors in Appendix G of the permit. We expect that the information listed 40 CFR §136 prevails, and will confirm this with EPA and update this table when the government reopens. Methods indicated in red are clearly incorrect. Those in brackets seem to have been inadvertently omitted.

<sup>2</sup>These are typical recommended values, if using a lab please update these columns with information provided by your lab.

<sup>3</sup>For the safety of personnel and the environment we do not recommend preserving samples with acid in the field.

## **Outfall Screening Quality Assurance and Quality Control**

In order to ensure the integrity of the data, grab samples collected in the field for later analysis will be properly preserved and processed within the allowable hold time for each parameter as summarized in Table 5 above. In the interest of employee and environmental safety, standard preservation methods that involve hazardous materials (i.e. sulfuric acid) may be avoided in the field. Certain parameters must be measured directly in the field using field meters or other instruments as indicated in Tables 3 and 5.

All measurements are taken or analysis completed in accordance with manufacturer's and / or laboratory's instructions or a town specific SOP adapted from the manufacturer's and or laboratory's instructions, as to calibration and testing.

In addition, to help further validate the reliability of testing measures being performed, when resources allow, the following additional quality assurance and quality control (QA/QC) measures may be implemented. These additional steps are not required by the MS4 permit:

- For field meters, post-calibration (pre-sampling) and post-sampling meter readings relative to a known calibration standard will be recorded.
- One lab blank, one lab positive or spike, and one lab split will be analyzed for each parameter on each mission (i.e. sampling day).
- Periodically, one field duplicate will be collected and analyzed for bacteria per mission.
- Where they are available, the results of QA/QC samples will be periodically evaluated and corrective measures including supplemental field team training will be undertaken as needed.

## **Follow-up ranking of outfalls and interconnections**

The purpose of follow-up ranking is to use the information gathered during the ongoing outfall screening process to determine the order in which associated catchments will be investigated.

Outfalls and interconnections may be reprioritized continuously as dry weather screening takes place. The NSP IDDE Prioritization Tool provides a framework for updating outfall rankings on a continuous basis. At a minimum, a follow up outfall and interconnection ranking will be completed by the end of year 3 of the permit (6/30/21) when dry weather outfall screening is complete.

All screening data for a given year will be included with that year's annual report, and any previously unknown outfalls or interconnections discovered during screening will be added to the outfall inventory and initial ranking, which is also submitted with the annual report.

Any outfalls that are found during screening to contain one or more of the following signs of sewage contamination will automatically be re-prioritized to the top of the high priority outfalls for catchment investigation:

- Olfactory or visual evidence of sewage;
- Ammonia  $\geq 0.5$  mg/L, surfactants  $\geq 0.25$  mg/L, and bacteria levels greater than the applicable water quality criteria for receiving water (235 CFU or MPN for E. coli or 61 CFU or MPN for Enterococcus); or
- Ammonia  $\geq 0.5$  mg/L, surfactants  $\geq 0.25$  mg/L and detectable levels of chlorine.

Please refer to the NSP IDDE Prioritization Tool, which details the Town's ranking process which considers numerous factors, but in general, outfalls with known illicit discharges or SSO history are categorized as "problem outfalls" and placed at the top of the ranking. Outfalls with any of the indicator combinations described above are placed at the top of the "high priority" list. Outfalls with high bacteria but low or

absent ammonia and surfactants are placed next in the overall ranking, followed by those with ammonia and/or surfactants but no other indicators. Where outfall screening discovers no contamination indicators, outfalls will be added to the “low priority” category. Outfalls without indicators but where available ambient stream water quality data indicates elevated levels of bacteria, will be moved to the high end of the low priority category. Rankings may also be adjusted in light of any known or suspected system vulnerability factors. Finally, higher priority will be given to catchments whose outfalls discharge to beaches, shell fishing areas or other public health priority areas.

At all times, the team leader will use their best judgment to schedule catchment investigations in the order that they believe is likely to lead to the most rapid identification and elimination of problem discharges to the MS4 and/or local waterways, and the team leader retains the discretion to adjust the prioritization as needed to accomplish that goal.

### **System Vulnerability Factors and Wet Weather Outfall Screening**

If an outfall or interconnection’s catchment contains one or more of the system vulnerability factors listed below, wet weather screening and sampling is required in addition to dry weather screening. The Town will document the presence or absence of system vulnerability factors in each catchment in the outfall inventory and ranking tool, an updated copy of which is included with each annual report.

System vulnerability factors may be known in advance of catchment investigation, or may be discovered during the course of the catchment historic records review or field investigation (see discussion below). If system vulnerability factors are known in advance, it is preferable but not required to conduct wet weather screening prior to catchment investigation so that the results can better inform the strategy employed during the investigation of each catchment.

If one or more system vulnerability factors is discovered during the course of catchment investigation, the wet weather screening will be completed concurrent with catchment investigation, and the associated catchment investigation may not be marked complete until wet weather screening is completed.

The NSP IDDE Prioritization Tool provides a framework for tracking which outfalls require wet weather screening and progress toward completion. The presence of one or more of the following required factors shall trigger wet weather screening.

#### **Required System Vulnerability Factors**

- History of SSOs, including, but not limited to, those resulting from wet weather, high water table, or fat/oil/grease blockages;
- Common or twin-invert manholes serving storm and sanitary sewer alignments;
- Common trench construction serving both storm and sanitary sewer alignments;
- Crossings of storm and sanitary sewer alignments where the sanitary system is shallower than the storm drain system;
- Sanitary sewer alignments known or suspected to have been constructed with an underdrain system;
- Inadequate sanitary sewer level of service (LOS) resulting in regular surcharging, customer back-ups, or frequent customer complaints;
- Areas formerly served by combined sewer systems;
- Sanitary sewer infrastructure defects such as leaking service laterals, cracked, broken, or offset sanitary infrastructure, directly piped connections between storm drain and sanitary sewer

infrastructure, or other vulnerability factors identified through Inflow/Infiltration Analyses, Sanitary Sewer Evaluation Surveys, or other infrastructure investigations.

### **Recommended but Not Required System Vulnerability Factors**

- Sewer pump/lift stations, siphons, or known sanitary sewer restrictions where power/equipment failures or blockages could readily result in SSOs;
- Any sanitary sewer and storm drain infrastructure greater than 40 years old;
- Widespread code-required septic system upgrades required at property transfers (indicative of inadequate soils, water table separation, or other physical constraints of the area rather than poor owner maintenance);
- History of multiple Board of Health actions addressing widespread septic system failures (indicative of inadequate soils, water table separation, or other physical constraints of the area rather than poor owner maintenance);

### **Wet Weather Outfall / Interconnection Screening and Sampling Field Procedures**

Wet weather outfall screening will primarily occur March to June when groundwater levels are relatively high per EPA's strong recommendation. Wet weather screening only occurs when there is a rainfall event sufficient to produce a stormwater discharge. In general, a minimum of 0.25 inches of rain in the previous 24 hour period is preferred prior to wet weather screening and the drain system must be actively flowing at the time of sampling. Sampling during periods of medium to high intensity rainfall / storm drain discharge is preferred if possible.

The initial surface runoff from a rainstorm, called the "first flush," should not be sampled, if possible. The objective of the wet weather screening is to identify SSOs and wet weather cross connections, rather than street runoff.

In addition to collecting samples, an outfall inspection form will be completed at the time of sampling to note any visual or olfactory indicators of illicit discharge. See Appendix E for applicable procedures and forms.

Because of the need to coordinate personnel, equipment and laboratory resources in advance, it is usually preferable to plan for wet weather sampling when the forecast likelihood of rainfall is 60% or higher. It is also generally preferable to plan wet weather sampling in anticipation of frontal weather systems rather than thunderstorms or other scattered weather systems.

In the event that an outfall or interconnection is submerged, the screening and sampling is completed at the first accessible upstream manhole that is not submerged and this location is noted on the inspection form.

The parameters to be sampled on a given waterbody and sampling methods, test kits, laboratory arrangements and QA/QC procedures are the same as for dry weather screening on that waterbody.

### **Catchment Investigation Procedure**

Each catchment associated with an outfall or interconnection within the MS4 (with the exception of excluded, not waters of the US and not owned by Town outfalls) will be investigated for indicators of illicit discharges, whether or not such indicators were found during outfall screening. Problem outfalls may bypass the dry weather outfall screening process and proceed directly to catchment investigation. High and low priority outfalls catchment investigations will begin once dry weather screening is complete.

Catchments are investigated one by one in order of priority without regard to geographic proximity. “problem” catchments are investigated first, followed by high priority and then low priority catchments. Within each prioritization category, the catchments are investigated in the order they are ranked. The NSP IDDE Prioritization Tool provides a framework for ranking individual outfalls for catchment investigation purposes and tracking the progress of the program.

Investigation of catchments associated with problem outfalls will begin within two years of the permit effective date (i.e. by 6/30/20) and will be completed by year seven (6/30/25). Work may be ongoing in multiple catchments simultaneously to expedite the process. All catchments (except those which are categorized as excluded, not waters of the US, or not Town owned must be investigated within ten years of the permit effective date (i.e. by 6/20/28).

### **Review of Records and Preparation of Investigation Strategy for Each Catchment**

Completed system mapping is critical to an effective catchment investigation. If the Phase 1, and Phase 2 mapping data described above under the section on system mapping has not been previously completed, this information will be gathered and updated concurrent with the investigation of each catchment. Where resources allow, the recommended mapping elements will also be collected at the same time.

Prior to beginning the investigation of a particular catchment, available mapping, as well as relevant, historic plans and records, and other sources of existing data for the catchment will be reviewed by the field team leader. For the Town, these data sources will include plans related to the construction of the storm drain and of sanitary sewers, prior work performed on the storm drains or sanitary sewers, board of health or other municipal data on septic system failures or required upgrades, and complaint records related to SSOs, sanitary sewer surcharges, and septic system breakout.

The locations of storm drains, sanitary sewers, and any combined sewer pipes and manholes are noted, as well as the outfall or interconnection location and receiving water. Information pertaining to any of the system vulnerability factors defined above, as well as the results of the outfall screening, will be considered during catchment investigation planning.

Any system vulnerability factors discovered during the records review or catchment field investigation process will be added to the system vulnerability inventory which is part of the outfall inventory ranking tool. The associated outfall will be scheduled for wet weather screening if one or more system vulnerability factors are identified, and the outfall/catchment rankings will be updated accordingly. The investigation of a catchment will not be considered complete until wet weather outfall screening is complete, if applicable.

The team will also note any system blockages or cleaning needs, and schedule appropriate maintenance activities as required, prior to field investigations if feasible.

Based on a review of the above information, an investigation strategy for the catchment will be developed. Specific manholes to be inspected will be defined for each catchment prior to beginning the field investigation of a catchment.

Junction manholes are those that receive flow from two or more drain segments. Key junction manholes receive the accumulated flow from two or more junction manholes or a junction manhole and an additional drain segment. Depending on its size and complexity, each catchment may have multiple junction and/or key junction manholes. Simple catchments may not have any junction or key junction manholes. Junction and key junction manholes are illustrated in Figure 1.



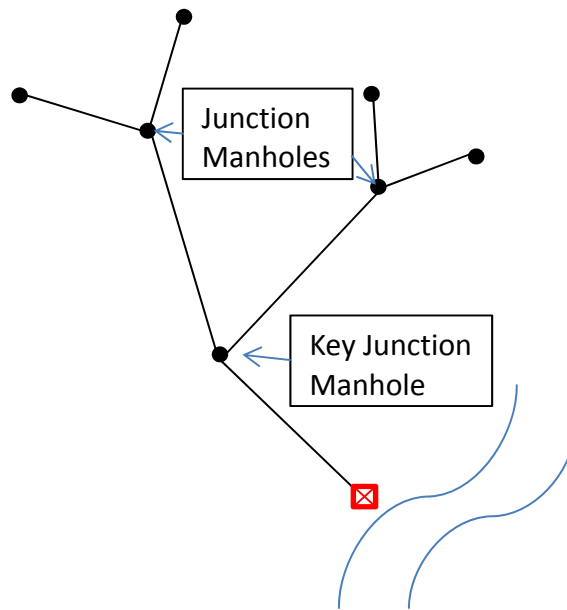

Figure 1: Junction and Key Junction Manholes

The resulting catchment investigation plan will include at a minimum, opening and inspection/testing of all key junction manholes—or, if no key junction manholes are present, junction manholes.

If no key junction or junction manholes are present, the dry and (if required) wet weather outfall inspections shall suffice for meeting the manhole inspection requirement, so long as the dry weather and (if required) wet weather outfall inspection reveal no indications of dry weather flow, illicit discharge or SSO activity. Where illicit discharge or SSO evidence is discovered, further manhole inspections or other investigations shall be conducted to isolate the affected pipe segment between two manholes as described further below.

### Dry Weather Manhole Inspection Methodology

At the discretion of the field team leader, manhole inspections may be performed starting from the outfall or interconnection and working upstream, or starting from the upper parts of the catchment and working downstream, or a combination of both practices.

Key junction manholes are inspected in each catchment where they exist. If no key junction manholes are present in the system, inspections will include junction manholes. If no junction manholes exist, then the results of the outfall screening/testing will serve as the catchment investigation provided that no flow, illicit discharge, or SSO indicators were found at the outfall.

During the investigation of a catchment, storm drain manholes are opened and inspected during dry weather (less than 0.1 inches of rain in the preceding 24 hours and no snowmelt, with 72 hours dry preferred) to look for evidence of illicit discharges.

A manhole inspection form is completed and any visual or olfactory evidence of illicit discharges is noted. Visual evidence may include toilet paper, sanitary products, visible sewage, soap, food, gray filamentous bacterial growth, excrement, or other indications of anything other than stormwater entering the MS4.

Olfactory evidence may include sewage, soap, laundry, bleach, food, or other odors not typical of stormwater.

If flow is observed in a storm drain manhole during dry weather, the team will use a field kit or laboratory grab sample to test the flow at a minimum for the presence of ammonia, chlorine, and surfactants using the procedures described above. In most cases these tests will be performed immediately on-site rather than being sent off to a lab so that they can be used to guide further investigations in real time. In the field team leader's discretion, samples may also be collected for E. coli and sent to the lab for analysis, especially where outfall inspection indicates potential presence of an illicit sewage discharge and/or flow is present but surfactant and ammonia tests are negative or inconclusive. E. coli sampling is recommended but not required by EPA.

In manholes where flow is present but at a level too low / shallow to be sampled, or where no flow is present but where visual or olfactory evidence of illicit discharge is found in the manhole, these indicators will be noted on the manhole inspection form and the team will in its discretion, either:

- A) Re-inspect the manhole within one week and if flow is found on re-inspection, it will be sampled;
- B) Dam the manhole with a sandbag or caulk dam, recheck after 48 hours of additional dry weather, and sample any discharge which has accumulated behind the dam (this process requires dry weather before, during and after placement of the dam); or
- C) Proceed to investigate the collection area upstream of the manhole immediately in an effort to isolate the source of the flow or visual / olfactory indicators, and then if no upstream indicators are found, return to the original problem manhole to implement option A or B.

Sampling results will be evaluated using the criteria described above in the section titled "Follow-up ranking of outfalls and interconnections." If the observed flow is obviously an illicit discharge based on visual or olfactory evidence, the field team may note this and skip the testing.

Manhole investigations will continue upstream of the problem manhole, beginning with upstream key junction or junction manholes (if any) in an effort to identify a specific section of pipe between two manholes where the source of the discharge originates, at which point the process moves on to isolation and confirmation procedures as described further below.

If positive indicators of illicit discharge are found in a manhole, investigations further downstream of that problem manhole will be put on hold until the source of the discharge upstream has been isolated, confirmed and corrected, although investigations may continue on other key junction or junction manholes in the catchment that are unaffected by the problem manhole, if any.

To the extent that a catchment investigation reveals a discharge that does not meet the definition of an illicit discharge (see definitions and acronyms above) but is nonetheless undesirable, such as single home car washing or runoff from irrigation systems, the Town may refer the issue to the NSP for targeted follow up education in the immediate neighborhood. If the Town determines that such discharges represent a significant source of pollutants to the MS4, more formal measures will be implemented to control these sources so they are no longer significant contributors of pollutants, and/or they are eliminated entirely.

### **Wet Weather Manhole Inspection / Catchment Investigation**

When an outfall or catchment is known or found to contain one or more system vulnerability factors as described above, the Town is required to conduct wet weather outfall or catchment investigations "to the

extent necessary to determine whether wet weather-induced high flows in sanitary sewers or high groundwater in areas served by septic systems result in discharges of sanitary flow to the MS4.”

At a minimum, this investigation will include the wet weather outfall screening procedure described in the section above titled “Wet Weather Outfall / Interconnection Screening and Sampling Field Procedures.” If necessary, investigations may also include additional inspections and testing in the catchment upstream of the outfall including but not limited to wet weather manhole inspection and sampling of the MS4 infrastructure, or in some cases inspection of associated sewer or septic infrastructure that may interact with the MS4 infrastructure during wet weather conditions.

The investigation of a catchment with one or more system vulnerability factors cannot be marked complete until the wet weather outfall screening and related wet weather catchment investigations (if any) are finalized.

### **Procedures to Isolate and Confirm Sources of Illicit Discharges**

Discharges of concern may include direct cross connections, indirect connections (i.e. exfiltration from a leaking sewer lateral, sewer line or septic system that infiltrates the drain), intermittent discharges of solid or liquid waste (i.e. catch basin dumping), input from features such as sewer underdrains, or SSOs. The nature of the specific investigation techniques used will vary depending on the nature of the suspected problem.

Once a section of pipe between two manholes has been isolated as the approximate location of a dry weather or wet weather discharge, further testing will be undertaken to isolate and confirm the source. Dye testing of buildings and sanitary sewer pipes, smoke testing, internal video inspection of drains, sewers or laterals, and targeted internal plumbing investigations are used to confirm the source of the illicit discharge.

During the process of attempting to isolate and confirm the source of illicit discharges in an upstream area of a catchment, similar investigations in downstream areas of the same catchment will be placed on hold. Once the source of the illicit discharge has been identified and the removal of the illicit discharge has been confirmed, downstream work in the same catchment can be resumed.

The process of locating the illicit discharge is described in further detail in the Towns illicit discharge isolation procedures which are found in Appendix E.

### **Marking the Catchment Investigation Complete**

If all key junction manholes have been inspected (or, if no key junction manholes are present, junction manholes, or, if no junction manholes are present, the outfall) and found to be free of dry weather flow or illicit discharge indicators, and any required wet weather outfall screening and catchment investigation has been completed, the investigation of that catchment is marked complete.

If sources of illicit discharge or SSO are found in a catchment, the investigation may be marked complete once the sources of the discharge have been isolated and confirmed as described above. In such cases the catchment may be marked “inspection complete, awaiting repair.” Once repairs are finished, further catchment investigation will be scheduled to confirm that all sources of discharge have been eliminated.

If all required manhole inspections are clean but the outfall inspection still shows evidence of illicit discharge, the catchment may be marked “inspection complete, results inconclusive” and the Town will

schedule further catchment investigation and/or outfall screening until such time as the source of illicit discharge has been identified, or the catchment has been confirmed to be free of illicit discharges. In these situations, the Town may elect to collect additional outfall or manhole samples and have them analyzed for more sophisticated sewage indicators such as pharmaceuticals (using EPA 1694 LC/MS/MS methods with EPA specified MDLs) to help determine the nature of the discharge.

### **Catchment Investigation Summary Report and Recordkeeping**

In order to document the process followed and results of wet and dry investigations in each catchment, the team leader will prepare a NSP Catchment Investigation Summary Report form. This form briefly describes the dates of the investigation, what investigation strategy was used, any system vulnerability factors discovered, any updates to mapping needed or completed, overview of sampling results, and the conclusions of the investigation. Where an illicit discharge is encountered, the report will also briefly outline measures taken to isolate the source, and any needed or completed repairs.

As catchment investigations proceed, the outfall inventory and ranking tool will be updated to reflect the status of each outfall's catchment investigation.

The summary report, updated outfall inventory and ranking as well as all catchment investigation field data will be included with the annual report each year to document the progress of the program.

### **Illicit Discharge Removal and Confirmation**

Once the source of an illicit discharge has been identified, the Town will immediately notify all responsible parties for any such discharge and require immediate cessation of improper disposal practices in accordance with its legal authorities. Elimination will be pursued diligently and in the interim, the Town will implement or require implementation of all reasonable and prudent measures to minimize the discharge of pollutants to and from its MS4.

Illicit discharges will be corrected within 60 days as required by the MS4 permit. For illicit discharges that cannot be corrected in 60 days, an expeditious schedule for elimination will be created within 60 days. When the source of an illicit discharge is identified, the Town will document the removal process using the procedures and forms. At a minimum, the following information is collected from each illicit discharge that is removed and this information is included in each annual report to EPA:

- Location of the discharge and source(s);
- A description of the discharge, method of discovery, date of discovery;
- Dates of discovery, elimination, mitigation and/or enforcement action; and
- An estimate of the volume of flow removed.

The volume of flow removed will be estimated using an assumed volume of sewage from a typical house of 240 gallons per day. If only one fixture in a building is illicitly connected, or if the building is not a single family home, or if the illicit discharge is not a sewage cross connection, the estimated amount of sewage will be proportionately reduced or increased as appropriate.

Following the removal of an illicit discharge, confirmation outfall screening will be performed as soon as reasonably possible and, at a minimum, within 1 year. The confirmatory screening shall be conducted in dry weather unless one or more system vulnerability factors have been identified in the catchment area where the discharge was found, in which case both dry weather and wet weather confirmatory screening shall be conducted. If confirmatory screening indicates evidence of additional illicit discharges, the catchment shall be scheduled for additional investigation.

## **On-going Screening**

Once all catchment investigations and (if applicable) illicit discharge removal and confirmation have been completed, each outfall or outgoing interconnection will be reprioritized and rescreened every 5 years. On-going screening consists of outfall / interconnection screening during dry weather and also during wet weather for catchments with one or more system vulnerability factors present. On-going screening is performed with the same methodology described above.

If follow-up screening indicates the presence of illicit discharges in the catchment, the catchment investigation procedure is once again implemented to locate and remove all sources of illicit discharges.

## **Illicit Discharge Prevention Procedures**

The Town has the following procedures in place to prevent illicit discharges to the MS4:

- Public Awareness
- Training of Public Employees – required annually for employees

Copies of the Town’s illicit discharge prevention procedures can be found as referenced in Appendix E.

### **Training**

The Town will provide annual training to all employees involved in IDDE program which will cover screening and investigation procedures and how to identify illicit discharges and SSOs. Information on the frequency and type of training shall be included in the Town’s annual report.

## **Recordkeeping, Data Management and Annual Reports**

The Town’s IDDE program involves a significant level of recordkeeping, data management and reporting which is the responsibility of the Town Engineer.

The Town has documented its IDDE program procedures in a series of key reference documents and standard operating procedures. These documents are relatively static in nature, and many of them are attached directly to the IDDE SWMP for documentation purposes. Note that forms in Appendix E may be used as either paper forms, or electronic equivalents.

The Town is required to submit an annual report each year of the permit term, including tracking and evaluating IDDE program success and the overall effectiveness of the IDDE program. At a minimum the Town will report the following as metrics of IDDE program progress in each annual report:

- The number of SSOs and illicit discharges identified and removed,
- The number and percent of total outfall catchments served by the MS4 evaluated using the catchment investigation procedure,
- All dry weather and wet weather screening and sampling results,
- The estimated volume of sewage removed, and
- The estimated annual phosphorous load reduction resulting from IDDE activities (for phosphorous TMDL communities)

The Town also maintains an extensive collection of program data which document the completed and ongoing field work and reporting on that field work. This information is constantly changing as work is completed or new events occur. The active copies of these data are maintained on one or more computer systems including spreadsheets, databases and/or the Town GIS system among other formats. Copies of most of these data, or summaries of them, are included in the annual reports as required. Because of their dynamic nature, most of these data are not included directly in the SWMP, but are available upon request or through the Town’s annual reports.

**Table 6: Summary of Key Program Data and Annual Reporting Requirements**

<b>Data Type</b>	<b>Storage Location</b>
SSO inventory covering period 7/1/2013 to present	DPW hard drive. Included in annual report.
Copies of completed MassDEP SSO reporting forms	DPW hard drive. Copies available upon request
System mapping	Town GIS system. Copies available upon request subject to data format constraints. Brief update on status of mapping included in each annual report.
NSP Outfall Inventory, Prioritization and Tracking Tool	DPW hard drive.
Completed dry weather, wet weather, confirmatory, and follow up outfall screening field data collection sheets	Town GIS system.
Dry weather, wet weather, confirmatory, and follow up outfall screening field, laboratory, and/or office water quality analysis reports	DPW hard drive.
Completed manhole inspection forms (noting any system vulnerability factors present)	DPW hard drive.
Manhole inspection field or lab data reports (if not included on inspection forms)	DPW hard drive.
Brief summary report on each catchment investigation and its results	DPW hard drive.
Documentation and data on illicit / SSO isolation and confirmation including dye testing reports, video inspection files and similar data.	DPW hard drive.
For each illicit discharge identified, a brief report describing its removal or if not yet removed, the plan to remove it as expeditiously as possible.	DPW hard drive.
Annual IDDE self-evaluation which includes at a minimum the following EPA required annual reporting metrics: <ul style="list-style-type: none"> <li>• Number of illicit discharges identified and corrected</li> <li>• Number of SSOs identified and removed</li> <li>• Number and percent of outfalls screened</li> <li>• Outfall/interconnection inspection data and sampling results</li> <li>• Volume of sewage removed</li> <li>• Number and identifier of catchments evaluated</li> </ul>	DPW hard drive. Included in annual report.
Documentation of frequency and type of annual IDDE employee training	DPW hard drive. Included in annual report.
Documentation of the basis for any changes to IDDE BMPs (including why current BMP is ineffective/infeasible and expected performance of replacement BMP)	DPW hard drive. Included in annual report.
Copies of any other stormwater or receiving-water monitoring performed or received by the Town.	DPW hard drive.

## References

40 C.F.R § 136. <https://tinyurl.com/y754r4rn>

Brown, E., D. Caraco and R. Pitt. 2004. Illicit Discharge Detection and Elimination: a Guidance Manual for Program Development and Technical Assessments. Center for Watershed Protection and University of Alabama. EPA X-82907801-0.U.S. EPA Office of Wastewater Management, Washington, D.C.

Central Massachusetts Regional Stormwater Coalition. Standard Operating Procedures # 1, 2, 10 and 13. Retrieved July 20, 2018, from <https://www.centrmastormwater.org/toolbox/pages/standard-operating-procedures>

Cooke, Ian and Tedder, Newt. Email communication between Ian Cooke, Neponset River Watershed Association and Newt Tedder, Region 01 EPA. November 28 2018. Accessed online at: <https://yourcleanwater.org/wp-content/uploads/2019/01/NSP-EPA-IDDE-Outfall-Clarification-Summary-Sheet.pdf>

Edwards and Kelcey, November 2006. Guidelines and Standard Operating Procedures: Illicit Discharge Detection and Elimination and Pollution Prevention/Good Housekeeping for Stormwater phase II communities in New Hampshire. New Hampshire Estuaries Project. Accessed online at: <https://scholars.unh.edu/prep/152/>

New England Interstate Water Pollution Control Commission, January 2003. Illicit Discharge Detection and Elimination Manual: A handbook for municipalities. NEIWPC. Accessed online at: [http://www.neiwpc.org/neiwpc\\_docs/iddmanual.pdf](http://www.neiwpc.org/neiwpc_docs/iddmanual.pdf)

USEPA, July 2018. General Permits For Stormwater Discharges From Small Municipal Separate Storm Sewer Systems In Massachusetts. USEPA. Accessed online at: <https://www3.epa.gov/region1/npdes/stormwater/ma/2016fpd/final-2016-ma-sms4-gp.pdf>

USEPA, November 2004. Lower Charles River Illicit Discharge Detection & Elimination (IDDE) Protocol Guidance for Consideration. USEPA. Accessed online at: <https://www.mass.gov/files/documents/2016/08/xv/appendxa.pdf>

USEPA, 2012. Draft EPA New England Bacterial Source Tracking Protocol. USEPA. Accessed online at <https://www3.epa.gov/region1/npdes/stormwater/ma/2014AppendixI.pdf>

# MCM 4: Construction Site Stormwater Runoff Control

Permit Part 2.3.5

## Objectives

The objective of an effective construction stormwater runoff control program is to minimize or eliminate erosion and maintain sediment on site so that it is not transported in stormwater and allowed to discharge to a water of the U.S. through the permittee's MS4.

Category: Construction Site Erosion & Sedimentation	Due Yr	Update	Reference / Remarks
4.1 Bylaw for sediment, erosion, debris, litter and sanitary waste	0	none	See 2.3.5. Everyone should already have this.
4.2 Written procedure for site plan review/ inspect/ enforce	1	none	See 2.3.5

## Introduction

The municipal separate storm sewer system (MS4) permit issued by the Environmental Protection Agency (EPA) to the Town of Foxborough (hereafter "the Town") requires the implementation of a construction site stormwater runoff control program that prevents pollutants from construction site stormwater runoff from entering the Town's MS4. In addition, the MA Wetlands Protection Act and the Town's Wetland Protection Bylaw (Chapter 267) extend similar protections to discharges directly to wetlands and waterways.

This document references the Town's construction site stormwater runoff control program in detail and specific authority in the Town's Stormwater Management Bylaw (Chapter 232) and Stormwater Management Regulations. This document was prepared based on a model provided by the Neponset Stormwater Partnership (NSP) and funded in part through a Community Innovation Challenge Grant and contributions from NSP member communities.

## Program Purpose

In the absence of appropriate and well-maintained controls, stormwater runoff from construction sites will discharge very high concentrations of harmful pollutants into MS4s and/or local waterways, and ultimately degrade local water quality. In addition to harmful solid wastes and chemicals that are commonly found on construction sites, sediment in construction site runoff is often the most destructive.

While sedimentation of streams and rivers is a naturally occurring process, un-managed sediment from construction site runoff fills and clogs waterways at a high rate, causing severe physical and biological harm to local habitat and water quality, and exacerbating flooding.

Land disturbing activities and new construction projects including redevelopment are important for economic growth, public access and safety, and overall improvements of daily life.



Establishment of a legal authority to implement construction site stormwater runoff control will help prevent sediment as well as construction site debris and chemicals from entering local water systems while still allowing for construction activity.

### Program Schedule

The MS4 permit defines the timeline for implementing the Town’s Construction Site Stormwater Runoff Control Program as summarized in Table 1 below.

**Table 1. Program Schedule**

<b>Construction Site Stormwater Runoff Control Task</b>	<b>Permit Schedule</b>
Sediment and Erosion Control Ordinance Adoption	May 01, 2008
Written Site Plan Review Procedures Adoption	Year 1 (June 30, 2019)
Written Site Inspection Procedures Adoption	Year 1 (June 30, 2019)
Implementation of Sediment and Erosion Control Program	Ongoing

### Responsible Parties

The Town’s Stormwater Management Bylaw empowers the Planning Board to enforce the construction site stormwater runoff control provisions of the bylaw. The Planning Board is responsible for coordinating the efforts of other departments when needed, ensuring that necessary interdepartmental communication occurs in a timely manner, and following up with other departments as needed regarding the status of their efforts.

Key contacts and roles for each of the other departments are as follows:

**Table 2: Responsible Parties**

<b>Implementation Role</b>	<b>Responsible Authority/Individual</b>
Construction Stormwater Enforcement Authority	Planning Board
Overall Supervision of Construction Stormwater Program	Planning Board
Person(s) Responsible for Site Plan Review	Planning Board and Consultant
Person(s) Authorized to Conduct Construction Site Inspection on Behalf of the Town	Planning Board and Consultant
Enforcement Authority for Construction Stormwater Compliance	Planning Board
Legal Support for Enforcement Actions	Planning Board
Person(s) Responsible for Construction Stormwater Recordkeeping	Department of Public works

## Construction Site Stormwater Runoff Control Program

Consistent with the requirements of the MS4 Permit, the Town is implementing and enforcing a program to reduce pollutants in stormwater runoff discharged from all construction activities. The objective of the construction site stormwater runoff control program is described in Section 2.3.5 of the 2016 MS4 permit. The Town's program includes the following key elements:

- 1) **Bylaw and Regulation.** The Town has enacted a bylaw consistent with 2.3.5.c.i to accomplish the following required elements of the construction site stormwater runoff program. The location of the Town's bylaws is online on the town website. The bylaw was adopted on May 8<sup>th</sup>, 2017 and the regulations are being finalized by the Planning Board.
  - A. Regulates land disturbance of one acre or more consistent with MS4 Permit part 2.3.5.a and disturbances of less than this area threshold if part of a larger common plan of development or sale that would exceed the threshold;
  - B. Establishes authority for conducting site inspections, taking enforcement action and imposing sanctions as described further below and consistent with MS4 Permit part 2.3.5.c.ii.
  - C. Establishes the following requirements and standards for erosion and sediment control BMPs consistent with MS4 Permit part 2.3.5.c.iii;
    - Compliance with the MA Stormwater Policy and Handbook
    - Minimize the amount of disturbed area and protect natural resources;
    - Stabilize sites when projects are complete or operations have temporarily ceased;
    - Protect slopes on the construction site;
    - Protect all storm drain inlets and armor all newly constructed outlets;
    - Use perimeter controls at the site;
    - Stabilize construction site entrances and exits to prevent off-site tracking;
    - Inspect stormwater controls at consistent intervals
  - D. Establishes requirements for construction site operators to control wastes such as concrete washout, discarded building materials, chemicals, litter, and sanitary waste consistent with MS4 Permit part 2.3.5.c.iv;
  - E. Establishes the written procedures for pre-construction site plan review consistent with MS4 Permit part 2.3.5.c.v. including requirements for review of:
    - Site design
    - Planned operations at the construction site
    - Planned sediment and erosion control BMPs to be use during the construction phase
    - Planned BMPs to manage runoff after construction (See the section on "Post Construction Runoff Controls" in this SWMP)
    - Consideration of potential water quality impacts

- Receipt and consideration of information received from the public
- Required evaluation of opportunities for the use of low impact development and green infrastructure, and encouragement for the utilization of these methods were feasible

2) **Written Procedures for Site Inspection.** The Town has established written site inspection procedures, site inspector qualifications, and site inspection tracking protocols that are consistent with MS4 Permit part 2.3.5.c.v. These policies and procedures supplement the authority to conduct site inspections established by the Town’s Stormwater Management Bylaw. The Town’s site inspection procedures are outlined in the Stormwater Management Regulations.

The Town’s procedures require that inspections shall occur twice at each regulated site, during construction of erosion and sediment control BMPs and after construction of BMPs to verify that they are working as described in the approved plans.

Site inspections shall be conducted by the Stormwater Authority or their designated agent in conformance with the standards outlined in the regulations. Inspection forms and protocols can be found in bylaws, regulations and standard operating procedures.

## Measurable Goals

**Table 3: Construction Site Stormwater Runoff Control Measurable Goals**

BMP #	BMP Description	Measurable Goals	Due Date
1	Sediment and Erosion Control Ordinance	Adopt bylaw and regulations. Review and update as needed.	2008
2	Site Plan Review Procedures	Conduct site plan review of 100% of jurisdictional project sites according to the procedures outlined above	6/30/2019
3	Site Inspection Procedures	Inspect 100% of construction sites as outlined in the above document and take enforcement actions as needed	6/30/2019

## Annual Reporting

The Town submits annual reports each year consistent with MS4 Permit part 2.3.5.c.v. The following indicators are tracked and included with the annual report:

- Number of project plans reviewed
- Number of construction site inspections performed, and percentage of sites inspected, and
- Number of enforcement actions undertaken.

The responsibility for supervising the reporting process is as indicated in Table 2 above.

## References

Central Massachusetts Regional Stormwater Coalition. Standard Operating Procedures # 5, 6, and 9. Retrieved February 11 2018, from <https://www.centralmastormwater.org/toolbox/pages/standard-operating-procedures>

Commonwealth of Massachusetts. Massachusetts Wetland Protection Act. Massachusetts General Laws Chapter 131 § 40. Accessed online at: <https://malegislature.gov/Laws/GeneralLaws/PartI/TitleXIX/Chapter131/Section40>

USEPA, July 2018. General Permits For Stormwater Discharges From Small Municipal Separate Storm Sewer Systems In Massachusetts. USEPA. Accessed online at: <https://www3.epa.gov/region1/npdes/stormwater/ma/2016fpd/final-2016-ma-sms4-gp.pdf>

USEPA, 2017. National Pollutant Discharge and Elimination System (NDPES) Construction General Permit (CGP). USEPA. Accessed online at: <https://www.epa.gov/npdes/epas-2017-construction-general-permit-cgp-and-related-documents>

Massachusetts Department of Environmental Protection (MassDEP). Wetlands Protection Act Regulations. Code of Massachusetts Regulations Title 310 10.00. Accessed online at: <https://www.mass.gov/files/documents/2016/08/vy/310cmr10a.pdf>

Envirocert International CPESC Program Information, Requirements, and Fees <https://www.envirocertintl.org/cpesc/cpesc-requirements-fees-processes/>

## MCM 5: Post Construction Stormwater Management in New Development and Redevelopment

Permit Part 2.3.6

### Objectives

The objective of an effective post construction stormwater management program is to reduce the discharge of pollutants found in stormwater to the MS4 through the retention or treatment of stormwater after construction on new or redeveloped sites and to ensure proper maintenance of installed stormwater controls.

Category: New Development and Redevelopment	Due Yr	Update	Reference / Remarks
5.1 Bylaw meeting 2003 post-construction requirements	0	none	Everyone should already have this.
5.1 Update post-construction stormwater bylaw	2	none	See 2.3.6.a. All communities must require BMPs optimized for phosphorous per Appendix H.II. Taunton communities must require BMPs optimized for nitrogen per Appendix H.I.
5.3 Report on street design, parking guidelines and related rules	4	none	See 2.3.6.b. Report becomes part of the SWMP.
5.4 Report on allowing green roofs, infiltration, rain harvesting	4	none	See 2.3.6.b. Report becomes part of the SWMP.
5.5 Identify/rank five or more existing permittee-owned sites that could be retrofitted	4	annually	See 2.3.6.d. By 6/30/2022 identify additional sites annually to maintain inventory of at least five sites. All towns rank BMPs based on P benefits, while Taunton communities also rank based on N, per Appendix H.

### Introduction

The municipal separate storm sewer system (MS4) permit issued by the Environmental Protection Agency (EPA) to the Town of Foxborough (hereafter “the Town”) requires the implementation of a post construction stormwater management plan to reduce the discharge of pollutants found in stormwater through the retention or treatment of stormwater after construction on new or redeveloped sites. This document describes the Town’s post construction stormwater management program in detail and specific authority in the Town’s Stormwater Management Bylaw and Regulation. This document was prepared based on a model provided by the Neponset Stormwater Partnership and funded in part through a Community Innovation Challenge Grant and contributions from NSP member communities.

## Program Purpose

The Town is required by the MS4 Permit to develop, implement, and enforce a program to address stormwater runoff in post construction to reduce the discharge of pollutants found in stormwater from all new development and redevelopment sites.

In other words, the MS4 Permit demands that the Town create a Town-run stormwater permitting program to require most public and private parties who are developing or redeveloping land, to obtain a permit that requires the use of various techniques to capture and clean up stormwater runoff before it reaches streams or wetlands.

The program is designed to lead the Town, over time, to develop stormwater management regulations that require targeted low impact design (LID) and green infrastructure (GI) stormwater systems to reduce impervious area, better simulate the natural hydrologic condition, and reduce impacts to local water quality.

## Program Schedule

The MS4 permit defines the required timeline for implementing the Town’s Post Construction Stormwater Management Program as summarized in Table 1 below.

**Table 1: Program Schedule**

<b>Post-Construction Stormwater Management Task</b>	<b>Permit Schedule</b>
Adoption of 2003 MS4 Program for Post Construction Stormwater Management	2008 (completed)
Operation of 2003 MS4 Post Construction Program	Until Expanded Program Adopted
Expanded Post Construction Stormwater Bylaw and/or Regulation Adoption	Year 2 (June 30, 2020)
Street Design and Parking Lot Guidelines Evaluation Report	Year 4 (June 30, 2022)
Green Infrastructure Report	Year 4 (June 30, 2022)
List of Five Municipal Retrofit Opportunities	Year 4 (June 30, 2022)
Identification of Additional Municipal Retrofit Opportunities to Maintain Minimum Inventory of Five Sites	Year 5 (June 30, 2023) and annually thereafter
Implementation of Post Construction Stormwater Program	Ongoing

## Responsible Parties

The Town’s Stormwater Management Bylaw empowers the Stormwater Authority to enforce the post construction stormwater runoff control provisions of the Bylaw. The Stormwater Authority has delegated day to day management, record keeping, reporting and other roles identified in Table 2. The Stormwater Authority is responsible for coordinating the efforts of other departments when needed, ensuring that necessary interdepartmental communication occurs in a timely manner, and following up with other departments as needed regarding the status of their efforts.

Key contacts and roles for each of the other departments are as follows:

**Table 2: Responsible Parties**

<b>Implementation Role</b>	<b>Responsible Authority/Individual</b>
Post Construction Stormwater Permitting Authority	Planning Board
Overall Supervision of Post Construction Stormwater Program	Planning Board
Site Plan Review	Planning Board
Site Inspection and Enforcement	Planning Board and DPW
Enforcement Legal Support	Town’s Legal Counsel
Preparation of Street and Parking Lot Design Report	Planning Board and DPW
Preparation of Green Infrastructure Report	DPW
Preparation and maintenance of Potential BMP Retrofit Inventory	DPW
Recordkeeping	DPW

## Massachusetts Stormwater Policy

The Massachusetts Stormwater Policy, issued by the Department of Environmental Protection defines performance and design standards under the authority of the Massachusetts Wetlands Protection Act and Massachusetts Clean Waters Act to prevent or reduce pollutants from reaching water bodies and control the quantity of runoff from a site.

Many of these performance standards are incorporated by reference in the MS4 permit part 2.3.6 a.ii.3 and 2.3.6.a.ii.4. However, the MS4 Permit includes some performance standards that go beyond and/or differ from what is required by the MA Stormwater Policy.

In addition, the geographic applicability of the MA Stormwater Policy differs somewhat from the geographic applicability of the MS4 Permit’s Post Construction stormwater requirements. The state rules apply to activity near wetlands, whereas the MS4 Permit applies to projects of a certain size wherever they are.

Table 3 below provides a brief description to serve as a quick reference of the Massachusetts Stormwater Standards. A link to the complete MA Stormwater Policy and Handbook can be found below in the “Key Program Documents” section of this SWMP.

**Table 3: Massachusetts Stormwater Policy Design Standards Overview**

MA Stormwater Handbook Standard	MA Stormwater Handbook Design Standard Description
Standard 1	No new stormwater conveyances allowed to discharge untreated stormwater
Standard 2*	Peak runoff rate control requirements
Standard 3*	Groundwater recharge requirements
Standard 5	Eliminate or reduce polluted discharge from higher pollutant loading land uses
Standard 6*	Protect Zone II or Interim Wellhead Protection Areas of public water supply
Standard 9	Implement long term operation maintenance practices
*Indicates standard is necessary and required for Section 401 water quality certification by MA.	

### Post Construction Stormwater Management Program

Consistent with the requirements of the MS4 permit, the Town is implementing and enforcing a program to reduce pollutants in stormwater runoff discharged after construction on new or redeveloped sites. The Town’s program includes the following key elements:

- 1) **Bylaw.** The Town has enacted a bylaw and regulations consistent with all requirements of section 2.3.6.a of the MS4 permit to accomplish the following required elements of the post construction site stormwater runoff program. The location of the Town’s bylaw and regulations are maintained at the online eCode which can be accessed from the Town website. The bylaw was adopted on May 8<sup>th</sup>, 2017 and the regulations are periodically updated.
- 2) **Street Design and Parking Lot Guidelines Report.** Consistent with the requirements of part 2.3.6.b of the MS4 permit, the Town is required to develop a report assessing current street design and parking lot guidelines and other local requirements that affect the creation of impervious cover within four (4) years of the effective date of the permit (June 30, 2022). The Town’s street design and parking lot guidelines report will be developed before 6/30/2022.
- 3) **Green Infrastructure Report.** Consistent with the requirements of part 2.3.6.c of the MS4 permit, the Town is required to develop a green infrastructure report assessing existing local regulations within four (4) years of the effective date of the permit (June 30, 2022). The Town’s green infrastructure report will be developed before 6/30/2022.
- 4) **List of Municipal Retrofit Opportunities.** Consistent with the requirements of 2.3.6.d of the MS4 permit, the Town is required to develop a list of municipal retrofit opportunities within four



(4) years of the effective date of the permit (June 30, 2022). The Town's list of Municipal Retrofit Opportunities will be developed before 6/30/2022.

## **Annual Reporting**

The Town is required to submit annual reports each year of the permit term. Evaluation of stormwater management for new development and redevelopment including status of ordinance development, review and status of the street design assessment, assessments to barriers to green infrastructure, and retrofit inventory status. The responsibility for supervising the reporting process is as indicated in Table 2 above. Yearly annual reporting includes the following:

**Bylaw.** The Town is required to report annually on its progress in adopting or amending its post construction stormwater bylaw.

**As-Built Plans and Ensuring Long Term O&M.** The Town is required to report annually on measures it has implemented to require as-built plans and ensure proper long-term operations and maintenance on properties where the Town has issued post construction stormwater permits.

**Street Design and Parking Lot Guidelines Annual Reporting Requirements.** The Town is required to report in each annual report on the status of this assessment including any planned or completed changes to local regulations and guidelines.

**Green Infrastructure Report Annual Reporting Requirements.** The Town is required to report in each annual report on its findings and progress towards making the practices allowable.

**List of Municipal Retrofit Opportunities Annual Reporting Requirements.** Beginning with the fifth year annual report (June 30, 2023) and in each subsequent annual report, the Town is required to identify additional permittee owned sites and infrastructure that could be retrofitted such that the permittee maintains a minimum of 5 sites in their inventory, until such a time as the permittee has less than five sites remaining. In addition, the Town will report on all properties that have been modified or retrofitted with BMPs to mitigate IA that were inventoried in accordance with this part. The permittee may also include in its annual report non-MS4 owned property that has been modified or retrofitted with BMPs to mitigate IA.

## Key Program Documents and Deliverables

Table 4 provides a listing of key program documents and required deliverables for Post Construction Stormwater Management and where copies of these documents may be found.

**Table 4: Resources for Post Construction Stormwater Management SWMP**

Category	Included Documents	Document Location
Post Construction Stormwater Bylaw and/or Regulations	<ul style="list-style-type: none"> <li>Stormwater Management Bylaw (<a href="#">link</a>)</li> <li>NSP Model Regulatory Guidance on Bacteria (<a href="#">link</a>)</li> </ul>	See Link
Additional Design Standards or Guidance Documents Used in Administering Post Construction Program	<ul style="list-style-type: none"> <li>MA Stormwater Standards (<a href="#">link</a>)</li> <li>MA Stormwater Handbook (<a href="#">link</a>)</li> <li>[NSP Model Regulatory Guidance on Bacteria (<a href="#">link</a>)]</li> </ul>	See Link
Street Design and Parking Lot Report	Appendix J	SWMP
Green Infrastructure Report	Appendix J	SWMP
Inventory of Municipal BMP Retrofit Opportunities	Appendix K	SWMP

## References

USEPA, July 2018. General Permits For Stormwater Discharges From Small Municipal Separate Storm Sewer Systems In Massachusetts. USEPA. Accessed online at:  
<https://www3.epa.gov/region1/npdes/stormwater/ma/2016fpd/final-2016-ma-sms4-gp.pdf>

Massachusetts Department of Environmental Protection, 2008. Massachusetts Stormwater Handbook and Stormwater Standards. MassDEP. Accessed online at:  
<https://www.mass.gov/guides/massachusetts-stormwater-handbook-and-stormwater-standards#stormwater-handbook-volume-1>

## Resources

### **Resources for Post Construction Bylaw**

EPA Model Ordinances for Post Construction Controls [\(Link\)](#)

### **Resources For Street Design and Parking Lot Guidelines Report**

EPA Checklist for Assessing Street and Parking Design Standards in NH and MA [\(Link\)](#)

EPA Sustainable Design and Green Building Toolkit for Local Governments [\(Link\)](#)

Mass.Gov Smart Growth Smart Energy Toolkit Low Impact Development Module [\(Link\)](#)

Center for Watershed Protection BMP Design Supplement for Cold Climates [\(Link\)](#)

Massachusetts Institute of Technology (MIT) Design Guidelines for Urban Stormwater Wetlands [\(Link\)](#)

Permeable Pavers Design Webinars and Specification ICPI [\(Link\)](#)

Center for Watershed Protection Better Site Design Code and Ordinance (COW) Worksheet [\(Link\)](#)

Center for Watershed Protection Better Site Design Code and Ordinance (COW) Scoring Spreadsheet [\(Link\)](#)

American Planning Association MA Chapter Neighbor Road Design Guidebook [\(Link\)](#)

### **Resources for Green Infrastructure Report**

MAPC Low Impact Regulatory Review Checklist [\(Link\)](#)

MAPC Low Impact Development Toolkit and Factsheets [\(Link\)](#)

Green Neighborhoods Open Space Residential Design in Massachusetts [\(Link\)](#)

Massachusetts Institute of Technology (MIT) Design Guidelines for Urban Stormwater Wetlands [\(Link\)](#)

NHDES Innovative Land Use Planning Techniques [\(Link\)](#)

Center for Watershed Protection Developing Off-site Stormwater Compliance [\(Link\)](#)

Rain Garden Alliance Raingarden Design Guide [\(Link\)](#)

Green Neighborhoods Open Space Residential Design in Massachusetts [\(Link\)](#)

## MCM 6: Good Housekeeping and Pollution Prevention for Permittee Owned Operations

Permit Part 2.3.7

### Objectives

The permittee shall implement an operations and maintenance program for permittee-owned operations that has a goal of preventing or reducing pollutant runoff and protecting.

Category: Good Housekeeping		Due Yr	Update	Reference / Remarks
6.1	Plan for optimizing catch basin cleaning	1	none	See 2.3.7.a.iii. Submit with annual report 9/28/19
6.2	Clean catch basins per plan, and report efforts and mass	1	annually	See 2.3.7.a.iii.
6.3	Sweep streets 1x or 2x per year, report miles and volume	1	annually	See 2.3.7.a.iii. Append H: 2x in P or N impaired areas, 1x elsewhere.
6.4	Inspect all stormwater treatment structures (excluding catch basins)	1	annually	See 2.3.7.a.iii.
6.5	Develop and implement winter road maintenance program	1	annually	See 2.3.7.a.iii. Plan to minimize salt (incl. storage and no in-water dumping).
6.6	Develop and implement a written SWPPP for listed facilities	2	none	See 2.3.7.b
6.7	Inventory permittee-owned parks, buildings, facilities and vehicle storage	2	annually	See 2.3.7.a.ii. Review and update annually.
6.8	Written O&M procedures for parks, buildings, facilities, vehicle storage	2	none	See 2.3.7.a.i. See also special provisions for N and P in Appendix H that apply to all communities.
6.9	Written program for maintaining MS4 infrastructure	2	none	See 2.3.7.a.iii. Becomes part of the SWMP. Will define schedules for many specific activities.
6.10	Cover or enclose salt piles	2	none	See 2.3.7.b
6.11	Nitrogen and/or phosphorous source identification report	4	none	See Appendix H, I.b and II.b. All must do this for P. Taunton communities must also do it for N.
6.12	Report on potential and planned BMP retrofits for P and/or N	5	none	See Appendix H, I.b and II.b. All must do this for P. Taunton communities must also do it for N.
6.13	Install one or more structural BMP demos for P and/or N	6	none	See Appendix H, I.b and II.b. All must do this for P. Taunton communities must also do it for N. Grant eligible if early.

## **Introduction**

The municipal separate storm sewer system (MS4) permit issued by the Environmental Protection Agency (EPA) to the Town of Foxborough (hereafter “the Town”) requires the implementation of an operations and maintenance program that prevents pollutants from Town-owned facilities and operations from entering the Town’s MS4.

This document describes the Town’s good housekeeping program in detail and in conjunction with the attachments listed in Table 4 below, constitutes the “Written Program Document” required by the permit. This document was prepared based on a model provided by the Neponset Stormwater Partnership and funded in part through a Community Innovation Challenge Grant and contributions from NSP member communities.

## **Program Purpose**

The purpose of the Town’s good housekeeping program is to implement an operations and maintenance program for Town-owned facilities and operations with a goal of preventing or reducing pollutant runoff and protecting water quality from all Town-owned operations. This program is meant to address pollutants that collect on roadways, parking areas, storage yards (including waste and salt storage areas), vehicle maintenance areas, and parks or open spaces to prevent discharge to the Town’s MS4 and local waterways.

## **Program Schedule**

The MS4 permit defines the required timeline for tasks in implementing the Town’s good housekeeping program as summarized in Table 1 below.

In addition to the items below, the Town is required to address several additional good housekeeping activities due to the presence of one or more water quality limited waters within or downstream of the Town, and/or one or more TMDLs which apply to the Town. These additional requirements are described further below in the section on “TMDLs and Water Quality Limited Waters”.

**Table 1: Program Schedule**

Good Housekeeping and Pollution Prevention Task	Permit Schedule
Facilities: Parks and Open Spaces Operations and Maintenance Procedures	Year 2 (June 30, 2020)
Facilities: Buildings and Facilities Operations and Maintenance Procedures	Year 2 (June 30, 2020)
Facilities: Vehicles and Equipment Operations and Maintenance Procedures	Year 2 (June 30, 2020)
Infrastructure: Written Catch basin Cleaning Program Procedures	Year 1 (June 30, 2019)
Infrastructure: Written Street Sweeping Program Procedures	Year 1 (June 30, 2019)
Infrastructure: Written Winter Road Maintenance Program Procedures	Year 1 (June 30, 2019)
Infrastructure: Stormwater Treatment Structures Inspection and Maintenance	Year 1 (June 30, 2019)
Infrastructure: Other Infrastructure Operations and Maintenance Procedures (if any)	Year 2 (June 30, 2020)
Implementation of Good Housekeeping Program	Ongoing

**Responsible Parties**

The Stormwater Authority has delegated day to day management, record keeping, and reporting to the Town’s Department of Public Works. The Department of Public Works is responsible for coordinating the efforts of other departments when needed, ensuring that necessary interdepartmental communication occurs in a timely manner, and following up with other departments as needed regarding the status of their efforts. The Town is required to keep extensive written (hardcopy or electronic) records of all good housekeeping activities including but not limited to maintenance, inspections, and training records. The Town Engineer will maintain the records associated with the good housekeeping program as well as development and implementation of the SWPPP(s).

**Table 2: Responsible Parties**

<b>Implementation Role</b>	<b>Responsible Authority/Individual</b>
Overall Supervision and Coordination of Good Housekeeping Program	Department of Public works
Facilities: Parks and Open Spaces Operations and Maintenance Program	Department of Public Works
Facilities: Buildings and Facilities Operations and Maintenance Program	Central Maintenance / Department of Public Works
Facilities: Vehicles and Equipment Operations and Maintenance Program	Department of Public Works
Infrastructure: Catch Basin Cleaning Program	Department of Public Works
Infrastructure: Street Sweeping Program	Department of Public Works
Infrastructure: Winter Road Maintenance Program	Department of Public Works
Infrastructure: Stormwater Treatment Structures Inspection and Maintenance	Department of Public Works
Infrastructure: Other Infrastructure Operations and Maintenance Program	Department of Public Works
Stormwater Pollution Prevention Plan (SWPPP)	Department of Public Works
Good Housekeeping Recordkeeping	Department of Public Works

### **Town-Owned Facilities Operations and Maintenance Programs**

An operation and maintenance program (“O&M Program”) is a formulated plan of careful work practices, routine cleaning, training, and surveillance to minimize exposure to stormwater. The plans and strategies will vary depending on the nature of the Town-owned facility. Establishing written plans and procedures will ensure proper long-term maintenance and continuity and consistency as staff members in various departments change over time. The O&M programs are a critical component of the Town’s efforts to control pollutants.

Within two years of the effective date of the MS4 Permit (6/30/2021), the Town will develop an inventory of all Town-owned facilities in the following program categories. The inventory of facilities will be reviewed annually and updated as needed.

The Town’s O&M Program for Town-owned facilities includes the following key programs:

- 1) **Parks and Open Space Program.** Consistent with the requirements of part 2.3.7.a.ii.1 of the MS4 permit, the Town will inventory all Town-owned parks and open space areas and develop and implement an operations and maintenance program for these areas.
- 2) **Buildings and Facilities Program.** Consistent with the requirements of part 2.3.7.a.ii.2 of the MS4 permit, the Town will inventory all Town-owned schools, town offices, police and fire



stations, municipal pools, parking garages and other town-owned or operated buildings or facilities and will develop and implement an operation and maintenance program for these areas.

3) **Vehicles and Equipment Program.** Consistent with the requirements of Part 2.3.7.a.ii.3 of the MS4 permit, the Town is will inventory all vehicle and equipment areas and develop and implement an operation and maintenance program that establishes procedures for the storage of Town-owned or operated vehicles, evaluates fueling areas, and ensures vehicle wash waters are not discharged to the MS4.

The location of the documents detailing each of the above programs can be found in Table 4 below.

## **Town-Owned Infrastructure Operations and Maintenance Programs**

Proper, consistent and timely operation and maintenance of town-owned MS4 infrastructure—including roadways, catch basins, stormwater treatment structures and other components of the system—is equally critical to prevention of pollution.

Within two years of the effective date of the MS4 Permit (6/30/2021), the Town will establish a written program detailing the activities and procedures the Town will implement to timely maintenance and pollution reduction.

The Town’s O&M Program for Town-owned infrastructure includes the following key programs:

1) **Catch Basin Cleaning Program.** Consistent with the requirements of Part 2.3.7.a.iii.2 of the MS4 permit, the Town will establish a schedule of routine catch basin inspection and cleaning to ensure that no catch basin will be more than 50 percent full at anytime. In addition, consistent with the requirements of Part 2.3.7.a.iii.4 of the MS4 permit, the Town is required by the MS4 permit to ensure proper storage of the debris removed from catch basins prior to disposal or reuse. Materials removed from catch basins shall be managed in compliance with current MassDEP policies for catch basin cleanings which are referenced in the catch basin cleaning section in Table 4.

2) **Street Sweeping Program.** Consistent with the requirements of Part 2.3.7.a.iii.3 of the MS4 permit, the Town is required to establish and implement procedures for sweeping and cleaning streets as well as Town-owned parking lots at least once per year in the spring.

In addition, consistent with the requirements of Part 2.3.7.a.iii.4 of the MS4 permit, the Town is required by the MS4 permit to ensure proper storage of the debris removed from streets prior to disposal or reuse. Materials swept from the streets shall be managed in compliance with current MassDEP policies for street sweeping which are referenced in the street sweeping section in Table 4.

3) **Winter Road Maintenance Program.** Consistent with the requirements of Part 2.3.7.a.iii.5 of the MS4 permit, the Town will establish and implement procedures for winter road maintenance including the use and storage of salt and sand, minimization of the use of sodium chloride and other chloride salts, evaluation of opportunities for use of alternative (non-chloride) materials,

and ensuring that snow disposal activities do not result in disposal of snow into waters of the United States.

**4) Stormwater Treatment Structures Program.** Consistent with the requirements of Part 2.3.7.a.iii.6 of the MS4 permit, the Town will establish inspection procedures and maintenance frequencies for stormwater treatment structures such as water quality swales, retention/detention basins, infiltration structures, proprietary treatment devices or other similar structures. Such structures (excluding catch basins) shall be inspected at least annually. The stormwater treatment structures program is a separate and distinct program from the catch basin cleaning program.

**5) Other Infrastructure Program.** Consistent with the requirements of Part 2.3.7.iii.1 of the MS4 permit, the Town will develop a program detailing the activities and procedures it will implement so that any other MS4 infrastructure not included above (if any) is maintained in a timely manner to reduce the discharge of pollutants to the MS4.

The location of the documents detailing each of the above programs can be found in Table 4 below.

### **Stormwater Pollution Prevention Plan (SWPPP)**

Consistent with Part 2.3.7.b of the MS4 permit, the Town [will create / has created] a Stormwater Pollution Prevention Plan (SWPPP) for each of the following Town owned or operated facilities where pollutants are exposed to stormwater. SWPPPs are required for facilities such as:

- Maintenance garages;
- Public works yards;
- Transfer stations; and
- Other waste handling facilities

The SWPPP is a separate and different document from the Stormwater Management Plan (SWMP). Because of the potential for higher pollution loading from these types of facilities, the SWPPP(s) are also separate from, and generally more detailed than, the O&M Plans required for parks and other town owned facilities.

If facilities are located at the same property, only one SWPPP is required. Furthermore, a SWPPP does not need to be developed for a facility if the Town has either previously developed a SWPPP or received a “no exposure” certification for the discharge under the Multi-Sector General Permit, or if the discharge is authorized under another NPDES permit.

The Town is required by the MS4 permit to develop and implement a written (hardcopy or electronic) SWPPP for the facilities described in Section 1.6 of this document within two (2) years from the effective date of the permit (June 30, 2020). Each SWPPP will be signed by a duly authorized representative in accordance with MS4 signatory requirements.

The location of the Town’s SWPP(s) can be found in Table 4 below.

### SWPPP Site Inspections

Consistent with Part 2.3.7.b.iii of the MS4 permit, facilities that require a SWPPP are inspected at least once each calendar quarter for all areas exposed to stormwater and all stormwater control measures. If during the inspections, or any other time, the Town identifies control measures that need repair or are not operating effectively, the Town will repair or replace them before the next anticipated storm event if possible, or as soon as practicable following that storm event. In the interim, the Town will have back-up measures in place.

### **Recordkeeping, Annual Review and Reporting**

The Town is required by the MS4 permit to maintain detailed written (hard copy or electronic) records and documentation of its various good housekeeping activities, including but not limited to maintenance activities, inspections, employee training, and key metrics.

The Town reports on the progress of program implementation in the annual report. Records not required to be submitted with the annual report are maintained for at least five years, unless the retention period is extended by EPA.

The responsibility for supervising the recordkeeping and reporting is as indicated in Table 2 above. Key recordkeeping and reporting requirements for various sections of the Good Housekeeping program are summarized below.

#### Municipally-Owned Facilities Recordkeeping and Reporting

Reporting and recordkeeping requirements for the Municipally-Owned Facilities Programs (Parks and Open Spaces, Buildings and Facilities, and Vehicles and Equipment) are all similar.

As detailed in Part 2.3.7.a.iv of the MS4 Permit, the Town will include the following in its annual report on Municipally-Owned Facilities:

- The status of the required inventory of Town-owned facilities and any subsequent updates;
- The status of the O&M programs for the Town-owned facilities and activities; and
- The maintenance activities associated with each.

Furthermore, the Town will keep the following additional written records of all required activities under the town-owned facilities programs which are not submitted with the annual report as detailed in Part 2.3.7.a.v of the MS4 Permit. These include but are not limited to:

- Maintenance activities,
- Inspections, and
- Training

#### Municipally-Owned Infrastructure Recordkeeping and Reporting

Reporting and recordkeeping requirements for the Municipally-Owned Infrastructure Programs have some common reporting elements with each other and the Municipally Owned Facilities Programs, but also have more detailed reporting requirements which are specific to some programs.

The common annual reporting elements for all the Municipally Owned Infrastructure Programs are as follows (as detailed in Part 2.3.7.a.iv of the MS4 Permit):

- The status of the required inventory of Town-owned infrastructure and any subsequent updates;
- The status of the O&M programs for the Town-owned infrastructure and activities; and
- The maintenance activities associated with each.

Furthermore, the Town will keep the following additional written records of all required activities under the town-owned facilities programs which are not submitted with the annual report as detailed in Part 2.3.7.a.v of the MS4 Permit. These include but are not limited to:

- Maintenance activities,
- Inspections, and
- Training

Additional program specific annual reporting requirements for specific Municipally Owned Infrastructure Programs include:

Catch Basin Cleaning Program Additional Annual Reporting:

- The Town's plan for optimizing catch basin cleaning, inspection plans, and its schedule for gathering information to develop the optimization plan required to document the optimization plan, including any metrics or other information used to reach the determination that the plan is optimal (first annual report only).
- The total number of catch basins,
- Number of catch basins inspected,
- Number of catch basins cleaned, and
- The total volume or mass of material removed from all catch basins.

Catch Basin Cleaning Program Additional Recordkeeping (Not Included with Annual Report)

- Logs of catch basin cleaning
- Logs of catch basin inspections
- Documentation of finding that a catch basin is >50% full in two consecutive cleanings, along with required tributary area inspection and resulting mitigation activities if any.

Street Sweeping Program Additional Annual Reporting:

- Number of miles cleaned or the volume or mass of material removed.
- For rural uncurbed roadways with no catch basins and limited access highways, the Town will either meet the required minimum inspection frequencies or develop and implement an inspection, documentation and targeted sweeping plan within two (2) years of the effective date of the permit (June 30, 2020), and submit such plan with its year one annual report (June 30, 2019).
- The same information as it applies to any sweeping implemented under the requirements of Appendix H of the MS4 Permit as described in the applicable section below.

Winter Road Maintenance Program Additional Annual Reporting:

- The Town is required to submit written plan and procedures for the winter road maintenance program with its year one annual report.

Stormwater Treatment Structures Program

- See basic requirements above.

### SWPPP Recordkeeping and Reporting

A variety of specific reporting and record keeping requirements apply to each SWPPP including

#### SWPPP Annual Reporting Requirements

- Documentation of each quarterly facility inspection consistent with Part 2.3.7.b.iii of the MS4 permit

#### SWPPP Recordkeeping Requirements (Not Included in Annual Report)

- Written (hardcopy or electronic) record of all required activities consistent with Part 2.3.7.b.v of the MS4 permit including but not limited to
  - maintenance,
  - inspections, and
  - training

## References

Central Massachusetts Regional Stormwater Coalition. Standard Operating Procedures # 3, 4, 7, and 14. Retrieved February 11 2018, from

<https://www.centralmastormwater.org/toolbox/pages/standard-operating-procedures>

USEPA, July 2018. General Permits For Stormwater Discharges From Small Municipal Separate Storm Sewer Systems In Massachusetts. USEPA. Accessed online at:

<https://www3.epa.gov/region1/npdes/stormwater/ma/2016fpd/final-2016-ma-sms4-gp.pdf>

## Resources

### **Resources for Operation and Maintenance**

Massachusetts Clean Water Toolkit [\(Link\)](#)

EPA Considerations for Green Infrastructure Maintenance [\(Link\)](#)

EPA Long-Term Operation and Maintenance for Green Infrastructure Success [\(Link\)](#)

Yale Survey of Green Infrastructure Maintenance Programs in the U.S. [\(Link\)](#)

University of New Hampshire Green Infrastructure Maintenance Checklist [\(Link\)](#)

### **Resources for Winter Road Maintenance**

Clear Roads Road Salt Winter Maintenance BMP Manual [\(Link\)](#)

# TMDLs and Water Quality Limited Waters

## Charles River Watershed Phosphorus TMDL

### **Applicability (RELIEVED)**

The Town of Foxborough was identified in section 2.2.1.b.i of the 2016 MS4 Permit as having land area within the Charles River Watershed and therefore subject to the requirements of the established TMDL for phosphorus. However, the contributory area extending into Foxborough is minimal; equaling only approximately 0.02 of the total 310 square miles. Because of this minimal contribution, the required percent reduction was set to 0%. Therefore, Foxborough has fulfilled its statutory requirements for compliance and should be relieved of the additional requirements in Appendix F part A.I.1.

**Table F-3 of the 2016 MS4 Permit, Appendix F**

Urbanized Area Annual Stormwater Phosphorus Load Reduction by Permittee Charles River Watershed				
Community	Baseline Watershed Phosphorus Load, kg/yr	Stormwater Phosphorus Load Reduction Requirement, kg/yr	Allowable Phosphorus Load, kg/yr	Stormwater Percent Reduction in Phosphorus Load (%)
Foxborough	2	0	2	0%

## Bacteria or Pathogens TMDL

### **Applicability (REQUIRED)**

The Town of Foxborough was identified in section 2.2.1.b.iii of the 2016 MS4 Permit as having waterbodies which tested positive for bacteria and/or pathogens with an established TMDL. Table F-8 in Appendix F of the permit identified the specific impairment for each waterbody. In December 2019, the Massachusetts Department of Environmental Protection approved the Year 2016 Integrated List of Waters which updated the segmentation, test results, categories and TMDLs for all waterbodies in Massachusetts (see section Receiving Water for full Foxborough list). As a result, the only segment now identified as having tested positive for bacteria and/or pathogens with TMDLs is the Neponset River (MA73-01), EPA TMDL No. 54840 *Final total Maximum Daily Loads of Bacteria for Neponset River Basin* (CN 121.5).

**Table F-8 of the 2016 MS4 Permit, Appendix F**

Primary Municipality	Segment ID	Waterbody Name	Indicator Organism
Foxborough	<del>MA62-39</del>	<del>Rumford River</del>	<del>Escherichia Coli (E. Coli)</del>
Foxborough	<del>MA62-47</del>	<del>Wading River</del>	<del>Escherichia Coli (E. Coli)</del>
Foxborough	<del>MA73-01</del>	<del>Neponset River</del>	<del>Fecal Coliform</del>
Foxborough	MA73-01	Neponset River	Escherichia Coli (E. Coli)

*\*Strikethrough according to removal by Year 2016 Integrated List of Waters*

## Bacteria or Pathogens TMDL - Additional Requirements

BMP	Due Year	Description
3 - IDDE	1	Rank outfalls to these receiving waters as high priority for IDDE implementation in the initial outfall ranking.
1 - Public Education	Annual	The permittee shall supplement its Residential program with an annual message encouraging the proper management of pet waste, including noting any existing ordinances where appropriate. The permittee or its agents shall disseminate educational materials to dog owners at the time of issuance or renewal of a dog license, or other appropriate time.
1 - Public Education	Annual	The permittee shall also provide information to owners of septic systems about proper maintenance in any catchment that discharges to a water body impaired for bacteria or pathogens.

## Total Nitrogen

### **Applicability (RELIEVED)**

The Town of Foxborough was identified in part 2.2.2.a of the 2016 MS4 Permit as having MS4 discharges to waterbodies that are impaired due to nitrogen (Total Nitrogen). However, as per the Year 2016 Integrated List of Waters, there are currently no waterbodies or tributaries in Foxborough now listed with this impairment. The requirements of part I.2.a.i of Appendix H in the 2016 MS4 Permit have thus been satisfied and therefore the Town should be relieved of the additional requirements.

## Total Phosphorus

### **Applicability (REQUIRED)**

The Town of Foxborough was identified in section 2.2.2.b of the 2016 MS4 Permit as having MS4 discharges to waterbodies that are impaired due to phosphorus (Total Phosphorus). The Year 2016 Integrated List of Waters has identified the following waterbodies with phosphorus as an impairment and is therefore required to comply with the additional requirements of Appendix H part II of the 2016 MS4 Permit.

### **Total Phosphorus – Impaired Water Bodies**

Water Body	Watershed	Segment ID
Neponset River	Boston Harbor: Neponset	MA73-01

Below is summary table of the additional requirements outlined in Appendix H part II for the 2016 MS4 Permit.



### Total Phosphorus - Additional Requirements

BMP	Due Year	Description
Public education and outreach	Annual	The permittee shall distribute an annual message in the spring (March/April) timeframe that encourages the proper use and disposal of grass clippings and encourages the proper use of slow-release and phosphorous-free fertilizers.
Public education and outreach	Annual	The permittee shall distribute an annual message in the summer (June/July) timeframe encouraging the proper management of pet waste, including noting any existing ordinances where appropriate.
Public education and outreach	Annual	The permittee shall distribute an annual message in the fall (August/September/October) timeframe encouraging the proper disposal of leaf litter.
Stormwater Management in New Development and Redevelopment	1	Adoption/amendment of the permittee’s ordinance or other regulatory mechanism shall include a requirement that new development and redevelopment stormwater management BMPs be optimized for phosphorus removal; retrofit inventory and priority ranking under 2.3.6.1.b shall include consideration of BMPs that infiltrate stormwater where feasible
Good House Keeping and Pollution Prevention for Permittee Owned Operations	1	Establish procedures to properly manage grass cuttings and leaf litter on permittee property, including prohibiting blowing organic waste materials onto adjacent impervious surfaces;
Good House Keeping and Pollution Prevention for Permittee Owned Operations	1	Increased street sweeping frequency of all municipal owned streets and parking lots subject to Permit part 2.3.7.a.iii.(c) to a minimum of two times per year, once in the spring (following winter activities such as sanding) and at least once in the fall (Sept 1 – Dec 1; following leaf fall).
Phosphorus Source Identification Report	4	<ol style="list-style-type: none"> <li>1. Calculation of total MS4 area draining to the water quality limited receiving water segments or their tributaries, incorporating updated mapping of the MS4 and catchment delineations produced pursuant to part 2.3.4.6,</li> <li>2. All screening and monitoring results pursuant to part 2.3.4.7.d., targeting the receiving water segment(s)</li> <li>3. Impervious area and DCIA for the target catchment</li> <li>4. Identification, delineation and prioritization of potential catchments with high phosphorus loading</li> <li>5. Identification of potential retrofit opportunities or opportunities for the installation of structural BMPs during redevelopment, including the removal of impervious area</li> </ol>
Potential Structural BMPs	5	The permittee shall evaluate all permittee-owned properties identified as presenting retrofit opportunities or areas for structural BMP installation under permit part 2.3.6.d.ii or identified in the Phosphorus Source Identification Report that are within the drainage area of the water quality limited water or its tributaries.

BMP	Due Year	Description
Potential Structural BMPs	6	The permittee shall plan and install a minimum of one structural BMP as a demonstration project within the drainage area of the water quality limited water or its tributaries within six years of the permit effective date. The demonstration project shall be installed targeting a catchment with high phosphorus load potential. The permittee shall install the remainder of the structural BMPs in accordance with the plan and schedule provided in the year 5 annual report

## Solids, Oil and Grease, or Metals

### Applicability (REQUIRED)

Part 2.2.2.e of the 2016 MS4 Permit indicates that any MS4 discharging directly to an impaired waterbody where oil and grease (Petroleum Hydrocarbons), solids (TSS or Turbidity) or metals (Cadmium, Copper, Iron, Lead or Zinc) is the cause of the impairment shall meet the requirements of Appendix H part V. The Year 2016 Integrated List of Waters has identified the following waterbodies with such impairments and the Town is therefore required to comply with the additional requirements.

### Solids, Oil and Grease, or Metals – Impaired Water Bodies

Water Body	Watershed	Segment ID
Neponset Reservoir	Boston Harbor: Neponset	MA73034
Neponset River	Boston Harbor: Neponset	MA73-01

### Solids, Oil and Grease, or Metals – Additional Requirements

BMP	Due Year	Description
Stormwater Management in New Development and Redevelopment	1	Stormwater management systems designed on commercial and industrial land use area draining to the water quality limited waterbody shall incorporate designs that allow for shutdown and containment where appropriate to isolate the system in the event of an emergency spill or other unexpected event.
Good House Keeping and Pollution Prevention for Permittee Owned Operations	Annual	Increased street sweeping frequency of all municipal owned streets and parking lots to a schedule determined by the permittee to target areas with potential for high pollutant loads. This may include, but is not limited to, increased street sweeping frequency in commercial areas and high density residential areas, or drainage areas with a large amount of impervious area. Prioritize inspection and maintenance for catch basins to ensure that no sump shall be more than 50 percent full. Clean catch basins more frequently if inspection and maintenance activities indicate excessive sediment or debris loadings. Each annual report shall include the street sweeping schedule determined by the permittee to target high pollutant loads.

**Appendix A**  
**Notice of Intent**

Part I: General Conditions

General Information

Name of Municipality or Organization: Town of Foxborough State: MA

EPA NPDES Permit Number (if applicable): MAR041115

Primary MS4 Program Manager Contact Information

Name: William Keegan Title: Town Manager

Street Address Line 1: 40 South Street

Street Address Line 2:

City: Foxborough State: MA Zip Code: 02035

Email: bkeegan@foxboroughma.gov Phone Number: (508) 543-1200

Fax Number:

Other Information

Stormwater Management Program (SWMP) Location (web address or physical location, if already completed):

Eligibility Determination

Endangered Species Act (ESA) Determination Complete? Yes

Eligibility Criteria (check all that apply): A B C

National Historic Preservation Act (NHPA) Determination Complete? Yes

Eligibility Criteria (check all that apply): A B C

Check the box if your municipality or organization was covered under the 2003 MS4 General Permit

MS4 Infrastructure (if covered under the 2003 permit)

Estimated Percent of Outfall Map Complete? 100% If 100% of 2003 requirements not met, enter an estimated date of completion (MM/DD/YY):

Web address where MS4 map is published: http://www.foxboroughma.gov/Pages/FoxboroughMA\_Highway/drainage%20system%20atlas.pdf

Regulatory Authorities (if covered under the 2003 permit)

Illicit Discharge Detection and Elimination (IDDE) Authority Adopted? Yes Effective Date or Estimated Date of Adoption (MM/DD/YY): 05/08/17

Construction/Erosion and Sediment Control (ESC) Authority Adopted? Yes Effective Date or Estimated Date of Adoption (MM/DD/YY): 05/08/17

Post-Construction Stormwater Management Adopted? Yes Effective Date or Estimated Date of Adoption (MM/DD/YY): 05/08/17



Click to lengthen table

## Notice of Intent (NOI) for coverage under Small MS4 General Permit

### Part III: Stormwater Management Program Summary

Identify the Best Management Practices (BMPs) that will be employed to address each of the six Minimum Control Measures (MCMs). For municipalities/organizations whose MS4 discharges into a receiving water with an approved Total Maximum Daily Load (TMDL) and an applicable waste load allocation (WLA), identify any additional BMPs employed to specifically support the achievement of the WLA in the TMDL section at the end of part III.

For each MCM, list each existing or proposed BMP by category and provide a brief description, responsible parties/departments, measurable goals, and the year the BMP will be employed (public education and outreach BMPs also requires a target audience). **Use the drop-down menus in each table or enter your own text to override the drop down menu.**

#### MCM 1: Public Education and Outreach

<b>BMP Media/Category</b> (enter your own text to override the drop down menu)	<b>BMP Description</b>	<b>Targeted Audience</b>	<b>Responsible Department/Parties</b> (enter your own text to override the drop down menu)	<b>Measurable Goal</b>	<b>Beginning Year of BMP Implementation</b>
Outreach Message	Mailing, website, event, school program, press coverage and/or other means	Residents	Neponset Stormwater Partnership	Raise awareness and modify behaviors to reduce pollutant loading	FY'22
Outreach Message	Mailing, website, event, school program, press coverage and/or other means	Businesses, Institutions and Commercial Facilities	Neponset Stormwater Partnership	Raise awareness and modify behaviors to reduce pollutant loading	FY'22
Outreach Message	Mailing, website, event, school program, press coverage and/or other means	Developers (construction)	Neponset Stormwater Partnership	Raise awareness and modify behaviors to reduce pollutant loading	FY'22
Outreach Message	Mailing, website, event, school program, press coverage and/or other means	Industrial Facilities	Neponset Stormwater Partnership	Raise awareness and modify behaviors to reduce pollutant loading	FY'22
Outreach Message	Mailing, website, event, school program, press coverage and/or other means	Residents	Neponset Stormwater Partnership	Raise awareness and modify behaviors to reduce pollutant loading	FY'23











## Notice of Intent (NOI) for coverage under Small MS4 General Permit

### Part III: Stormwater Management Program Summary *(continued)*

#### MCM 3: Illicit Discharge Detection and Elimination (IDDE)

<b>BMP Categorization</b> <small>(enter your own text to override the drop down menu)</small>	<b>BMP Description</b>	<b>Responsible Department/Parties</b> <small>(enter your own text to override the drop down menu)</small>	<b>Measurable Goal</b> <small>(all text can be overwritten)</small>	<b>Beginning Year of BMP Implementation</b>
SSO inventory	Develop SSO inventory in accordance of permit conditions	DPW Operations	Complete within 1 year of effective date of permit	FY'19
Storm sewer system map	Create map and update during IDDE program completion	DPW Operations	Update map within 2 years of effective date of permit and complete full system map 10 years after effective date of permit	FY'20
Written IDDE program	Create written IDDE program	DPW Construction	Complete within 1 year of the effective date of permit and update as required	FY'19
Implement IDDE program	Implement catchment investigations according to program and permit conditions	DPW Operations	Complete 7 to 10 years after effective date of permit. Begin problem catchments within 2 years.	FY'20
Employee training	Train employees on IDDE implementation	DPW Operations	Train annually	FY'19
Conduct dry weather screening	Conduct in accordance with outfall screening procedure and permit conditions	DPW Operations	Complete 3 years after effective date of permit	FY'21
Conduct wet weather screening	Conduct in accordance with outfall screening procedure	DPW Operations	Complete 7 to 10 years after effective date of permit	FY'22
Ongoing screening	Conduct dry weather and wet weather screening (as necessary)	DPW Operations	Complete ongoing outfall screening every five years upon completion of IDDE program	FY'30



## Notice of Intent (NOI) for coverage under Small MS4 General Permit

### Part III: Stormwater Management Program Summary *(continued)*

#### MCM 4: Construction Site Stormwater Runoff Control

<b>BMP Categorization</b> (enter your own text to override the drop down menu or entered text)	<b>BMP Description</b>	<b>Responsible Department/Parties</b> (enter your own text to override the drop down menu)	<b>Measurable Goal</b> (all text can be overwritten)	<b>Beginning Year of BMP Implementation</b>
Site inspection and enforcement of Erosion and Sediment Control (ESC) measures	Complete written procedures of site inspections and enforcement procedures	Conservation Committee	Complete within 1 year of the effective date of permit	FY'19
Site plan review	Complete written procedures of site plan review and begin implementation	Planning/zoning Department	Complete within 1 year of the effective date of permit	FY'19
Erosion and Sediment Control	Adoption of requirements for construction operators to implement a sediment and erosion control program	Conservation Committee	Complete within 1 year of the effective date of permit	FY'19
Waste Control	Adoption of requirements to control wastes, including but not limited to, discarded building materials, concrete truck wash out, chemicals, litter, and sanitary wastes	Building Permitting and Enforcement	Complete within 1 year of the effective date of permit	FY'19



## Notice of Intent (NOI) for coverage under Small MS4 General Permit

### Part III: Stormwater Management Program Summary (continued)

#### MCM 5: Post-Construction Stormwater Management in New Development and Redevelopment

<b>BMP Categorization</b> (enter your own text to override the drop down menu or entered text)	<b>BMP Description</b>	<b>Responsible Department/Parties</b> (enter your own text to override the drop down menu)	<b>Measurable Goal</b> (all text can be overwritten)	<b>Beginning Year of BMP Implementation</b>
As-built plans for on-site stormwater control	The procedures to require submission of as-built drawings and ensure long term operation and maintenance will be a part of the SWMP	Planning/zoning Department	Require submission of as-built plans for completed projects	FY'20
Target properties to reduce impervious areas	Identify at least 5 permittee-owned properties that could be modified or retrofitted with BMPs to reduce impervious areas and update annually	Neponset Stormwater Partnership	Complete 4 years after effective date of permit and report annually on retrofitted properties	FY'22
Allow green infrastructure	Develop a report assessing existing local regulations to determine the feasibility of making green infrastructure practices allowable when appropriate site conditions exist	Neponset Stormwater Partnership	Complete 4 years after effective date of permit and implement recommendations of report	FY'22
Street design and parking lot guidelines	Develop a report assessing requirements that affect the creation of impervious cover. The assessment will help determine if changes to design standards for streets and parking lots can be modified to support low impact design options.	Neponset Stormwater Partnership	Complete 4 years after effective date of permit and implement recommendations of report	FY'22





## Notice of Intent (NOI) for coverage under Small MS4 General Permit

### Part III: Stormwater Management Program Summary (continued)

#### MCM 6: Municipal Good Housekeeping and Pollution Prevention

<b>BMP Categorization</b> (enter your own text to override the drop down menu or entered text)	<b>BMP Description</b>	<b>Responsible Department/Parties</b> (enter your own text to override the drop down menu)	<b>Measurable Goal</b> (all text can be overwritten)	<b>Beginning Year of BMP Implementation</b>
O&M procedures	Create written O&M procedures including all requirements contained in 2.3.7.a.ii for parks and open spaces, buildings and facilities, and vehicles and equipment	DPW Operations	Complete and implement 2 years after effective date of permit	FY'20
Inventory all permittee-owned parks and open spaces, buildings and facilities, and vehicles and equipment	Create inventory	DPW Operations	Complete 2 years after effective date of permit and implement annually	FY'20
Infrastructure O&M	Establish and implement program for repair and rehabilitation of MS4 infrastructure	DPW Operations	Complete 2 years after effective date of permit	FY'20
Stormwater Pollution Prevention Plan (SWPPP)	Create SWPPPs for maintenance garages, transfer stations, and other waste-handling facilities	DPW Operations	Complete and implement 2 years after effective date of permit	FY'20
Catch basin cleaning	Establish schedule for catch basin cleaning such that each catch basin is no more than 50% full and clean catch basins on that schedule	DPW Operations	Clean catch basins on established schedule and report number of catch basins cleaned and volume of material moved annually	FY'19
Street sweeping program	Sweep all streets and permittee-owned parking lots in accordance with permit conditions	DPW Operations	Sweep all streets and permittee-owned parking lots once per year in the spring	FY'19
Road salt use optimization program	Establish and implement a program to minimize the use of road salt	DPW Operations	Implement salt use optimization during deicing season	FY'19







--

--

--

--

Part IV: Notes and additional information

Use the space below to indicate the part(s) of 2.2.1 and 2.2.2 that you have identified as not applicable to your MS4 because you do not discharge to the impaired water body or a tributary to an impaired water body due to nitrogen or phosphorus. Provide all supporting documentation below or attach additional documents if necessary. Also, provide any additional information about your MS4 program below.

- 1) Where a "beginning year" is requested, we have listed the applicable fiscal year. Fiscal years run from July 1 to June 30 and correspond to permit years (i.e. permit year 1 is FY'19)
- 2) Part II Summary of Receiving Waters: A number of waterways into which we discharge do not have a defined MassDEP waterbody segment as indicated in the MassGIS datalayer. In these cases, outfalls have been attributed to the first segment downstream.

**Part V: Certification**

*I certify under penalty of law that this document and all attachments were prepared under my direction or supervision in accordance with a system designed to assure that qualified personnel properly gather and evaluate the information submitted. Based on my inquiry of the person or persons who manage the system, or those persons directly responsible for gathering the information, I certify that the information submitted is, to the best of my knowledge and belief, true, accurate, and complete. I am aware that there are significant penalties for submitting false information, including the possibility of fine and imprisonment for knowing violations.*

Name:  Title:

Signature:  Digitally signed by William Keegan  
Date: 2018.09.29 12:05:32 -04'00' Date:

*[To be signed according to Appendix B, Subparagraph B.11, Standard Conditions]*

Note: When prompted during signing, save the document under a new file name

**NOI Submission**

Please submit the form electronically via email using the "Submit by Email" button below or send in a CD with your completed NOI. You may also print and submit via mail using the address below if you choose not to submit electronically. The outfall map required in Part I of the NOI (if applicable) can be submitted electronically as an email attachment OR as a paper copy.

**Permittees that choose to submit their NOI electronically by email or by mailing a CD with the completed NOI form to EPA, will be able to download a partially filled Year 1 Annual Report at a later date from EPA.**

Submit by email using this button. Or, send an email with attachments to: [stormwater.reports@epa.gov](mailto:stormwater.reports@epa.gov)

Save NOI for your records

**EPA Submittal Address:**

United States Environmental Protection Agency  
5 Post Office Square - Suite 100  
Mail Code - OEP06-1  
Boston, Massachusetts 02109-3912  
ATTN: Newton Tedder

**State Submittal Address:**

Massachusetts Department of Environmental Protection  
One Winter Street - 5th Floor  
Boston, MA 02108  
ATTN: Fred Civian





**TOWN OF FOXBOROUGH**  
**Department of Public Works**

70 Elm Street  
Foxborough, Massachusetts 02035  
Tel. (508) 543-1228 / Fax. (508) 543-1227

**To:** Michelle Vuto – Stormwater & Construction Permits  
U.S. EPA Region 1

**From:** Chris Gallagher, Town Engineer

**Date:** 2/11/19

**Subject:** **ESA Eligibility – MS4 NOI**

Only USFWS Category C species are present in the Town of Foxborough. The Town does not expect the MS4 implementation activities to adversely affect the endangered species in this category.

If you wish to discuss this issue further, please call me (781-389-6139) at your convenience.

  
\_\_\_\_\_  
Christopher Gallagher



**Appendix B**  
**Authorization Letter**



UNITED STATES ENVIRONMENTAL PROTECTION AGENCY  
REGION 1  
5 POST OFFICE SQUARE, SUITE 100  
BOSTON, MA 02109-3912

**VIA EMAIL**

April 5, 2019

William Keegan  
Town Manager

And;

William Keegan  
Town Manager  
40 South Street  
Foxborough, MA. 02035  
bkeegan@foxboroughma.gov

Re: National Pollutant Discharge Elimination System Permit ID #: MAR041115, Town of Foxborough

Dear William Keegan:

The 2016 NPDES General Permit for Stormwater Discharges from Small Municipal Separate Storm Sewer Systems in Massachusetts (MS4 General Permit) is a jointly issued EPA-MassDEP permit. Your Notice of Intent (NOI) for coverage under this MS4 General Permit has been reviewed by EPA and appears to be complete. You are hereby granted authorization by EPA and MassDEP to discharge stormwater from your MS4 in accordance with the applicable terms and conditions of the MS4 General Permit, including all relevant and applicable Appendices. This authorization to discharge expires at midnight on **June 30, 2022**.

For those permittees that certified Endangered Species Act eligibility under Criterion C in their NOI, this authorization letter also serves as EPA's concurrence with your determination that your discharges will have no effect on the listed species present in your action area, based on the information provided in your NOI.

As a reminder, your first annual report is due by **September 30, 2019** for the reporting period from May 1, 2018 through June 30, 2019.

Information about the permit and available resources can be found on our website: <https://www.epa.gov/npdes-permits/massachusetts-small-ms4-general-permit>. Should you have

any questions regarding this permit please contact Newton Tedder at [tedder.newton@epa.gov](mailto:tedder.newton@epa.gov) or (617) 918-1038.

Sincerely,



Thelma Murphy, Chief  
Stormwater and Construction Permits Section  
Office of Ecosystem Protection  
United States Environmental Protection Agency, Region 1

and;



Lealdon Langley, Director  
Wetlands and Wastewater Program  
Bureau of Water Resources  
Massachusetts Department of Environmental Protection

**Appendix C**  
**IPaC Resource List**

# IPaC resource list

This report is an automatically generated list of species and other resources such as critical habitat (collectively referred to as *trust resources*) under the U.S. Fish and Wildlife Service's (USFWS) jurisdiction that are known or expected to be on or near the project area referenced below. The list may also include trust resources that occur outside of the project area, but that could potentially be directly or indirectly affected by activities in the project area. However, determining the likelihood and extent of effects a project may have on trust resources typically requires gathering additional site-specific (e.g., vegetation/species surveys) and project-specific (e.g., magnitude and timing of proposed activities) information.

Below is a summary of the project information you provided and contact information for the USFWS office(s) with jurisdiction in the defined project area. Please read the introduction to each section that follows (Endangered Species, Migratory Birds, USFWS Facilities, and NWI Wetlands) for additional information applicable to the trust resources addressed in that section.

## Location

Bristol and Norfolk counties, Massachusetts



## Local office

New England Ecological Services Field Office

☎ (603) 223-2541

📠 (603) 223-0104

70 Commercial Street, Suite 300  
Concord, NH 03301-5094

<http://www.fws.gov/newengland>

# Endangered species

**This resource list is for informational purposes only and does not constitute an analysis of project level impacts.**

The primary information used to generate this list is the known or expected range of each species. Additional areas of influence (AOI) for species are also considered. An AOI includes areas outside of the species range if the species could be indirectly affected by activities in that area (e.g., placing a dam upstream of a fish population, even if that fish does not occur at the dam site, may indirectly impact the species by reducing or eliminating water flow downstream). Because species can move, and site conditions can change, the species on this list are not guaranteed to be found on or near the project area. To fully determine any potential effects to species, additional site-specific and project-specific information is often required.

Section 7 of the Endangered Species Act **requires** Federal agencies to "request of the Secretary information whether any species which is listed or proposed to be listed may be present in the area of such proposed action" for any project that is conducted, permitted, funded, or licensed by any Federal agency. A letter from the local office and a species list which fulfills this requirement can **only** be obtained by requesting an official species list from either the Regulatory Review section in IPaC (see directions below) or from the local field office directly.

For project evaluations that require USFWS concurrence/review, please return to the IPaC website and request an official species list by doing the following:

1. Draw the project location and click CONTINUE.
2. Click DEFINE PROJECT.
3. Log in (if directed to do so).
4. Provide a name and description for your project.
5. Click REQUEST SPECIES LIST.

Listed species<sup>1</sup> and their critical habitats are managed by the [Ecological Services Program](#) of the U.S. Fish and Wildlife Service (USFWS) and the fisheries division of the National Oceanic and Atmospheric Administration (NOAA Fisheries<sup>2</sup>).

Species and critical habitats under the sole responsibility of NOAA Fisheries are **not** shown on this list. Please contact [NOAA Fisheries](#) for [species under their jurisdiction](#).

1. Species listed under the [Endangered Species Act](#) are threatened or endangered; IPaC also shows species that are candidates, or proposed, for listing. See the [listing status page](#) for more information.
2. [NOAA Fisheries](#), also known as the National Marine Fisheries Service (NMFS), is an office of the National Oceanic and Atmospheric Administration within the Department of Commerce.

The following species are potentially affected by activities in this location:

## Mammals

NAME

STATUS

Northern Long-eared Bat *Myotis septentrionalis*  
No critical habitat has been designated for this species.  
<https://ecos.fws.gov/ecp/species/9045>

Threatened

## Critical habitats

Potential effects to critical habitat(s) in this location must be analyzed along with the endangered species themselves.

THERE ARE NO CRITICAL HABITATS AT THIS LOCATION.

## Migratory birds

Certain birds are protected under the Migratory Bird Treaty Act<sup>1</sup> and the Bald and Golden Eagle Protection Act<sup>2</sup>.

Any person or organization who plans or conducts activities that may result in impacts to migratory birds, eagles, and their habitats should follow appropriate regulations and consider implementing appropriate conservation measures, as described [below](#).

1. The [Migratory Birds Treaty Act](#) of 1918.
2. The [Bald and Golden Eagle Protection Act](#) of 1940.

Additional information can be found using the following links:

- Birds of Conservation Concern <http://www.fws.gov/birds/management/managed-species/birds-of-conservation-concern.php>
- Measures for avoiding and minimizing impacts to birds <http://www.fws.gov/birds/management/project-assessment-tools-and-guidance/conservation-measures.php>
- Nationwide conservation measures for birds <http://www.fws.gov/migratorybirds/pdf/management/nationwidestandardconservationmeasures.pdf>

The birds listed below are birds of particular concern either because they occur on the [USFWS Birds of Conservation Concern](#) (BCC) list or warrant special attention in your project location. To learn more about the levels of concern for birds on your list and how this list is generated, see the FAQ [below](#). This is not a list of every bird you may find in this location, nor a guarantee that every bird on this list will be found in your project area. To see exact locations of where birders and the general public have sighted birds in and around your project area, visit the [E-bird data mapping tool](#) (Tip: enter your location, desired date range and a species on your list). For projects that occur off the Atlantic Coast, additional maps and models detailing the relative occurrence and abundance of bird species on your list are available. Links to additional information about Atlantic Coast birds, and other important information about your migratory bird list, including how to properly interpret and use your migratory bird report, can be found [below](#).

For guidance on when to schedule activities or implement avoidance and minimization measures to reduce impacts to migratory birds on your list, click on the PROBABILITY OF PRESENCE SUMMARY at the top of your list to see when these birds are most likely to be present and breeding in your project area.

NAME

BREEDING SEASON (IF A BREEDING SEASON IS INDICATED FOR A BIRD ON YOUR LIST, THE BIRD MAY BREED IN YOUR PROJECT AREA SOMETIME WITHIN THE TIMEFRAME SPECIFIED, WHICH IS A VERY LIBERAL ESTIMATE OF THE DATES INSIDE WHICH THE BIRD BREEDS ACROSS ITS ENTIRE RANGE. "BREEDS ELSEWHERE" INDICATES THAT THE BIRD DOES NOT LIKELY BREED IN YOUR PROJECT AREA.)

**Bald Eagle** *Haliaeetus leucocephalus*

Breeds Oct 15 to Aug 31

This is not a Bird of Conservation Concern (BCC) in this area, but warrants attention because of the Eagle Act or for potential susceptibilities in offshore areas from certain types of development or activities.

<https://ecos.fws.gov/ecp/species/1626>

**Black-billed Cuckoo** *Coccyzus erythrophthalmus*

Breeds May 15 to Oct 10

This is a Bird of Conservation Concern (BCC) throughout its range in the continental USA and Alaska.

<https://ecos.fws.gov/ecp/species/9399>

**Bobolink** *Dolichonyx oryzivorus*

Breeds May 20 to Jul 31

This is a Bird of Conservation Concern (BCC) throughout its range in the continental USA and Alaska.

**Canada Warbler** *Cardellina canadensis*

Breeds May 20 to Aug 10

This is a Bird of Conservation Concern (BCC) throughout its range in the continental USA and Alaska.

**Evening Grosbeak** *Coccothraustes vespertinus*

Breeds elsewhere

This is a Bird of Conservation Concern (BCC) throughout its range in the continental USA and Alaska.

**Kentucky Warbler** *Oporornis formosus*

Breeds Apr 20 to Aug 20

This is a Bird of Conservation Concern (BCC) throughout its range in the continental USA and Alaska.



Lesser Yellowlegs *Tringa flavipes*

This is a Bird of Conservation Concern (BCC) throughout its range in the continental USA and Alaska.

<https://ecos.fws.gov/ecp/species/9679>

Breeds elsewhere

Prairie Warbler *Dendroica discolor*

This is a Bird of Conservation Concern (BCC) throughout its range in the continental USA and Alaska.

Breeds May 1 to Jul 31

Red-throated Loon *Gavia stellata*

This is a Bird of Conservation Concern (BCC) throughout its range in the continental USA and Alaska.

Breeds elsewhere

Rusty Blackbird *Euphagus carolinus*

This is a Bird of Conservation Concern (BCC) throughout its range in the continental USA and Alaska.

Breeds elsewhere

Semipalmated Sandpiper *Calidris pusilla*

This is a Bird of Conservation Concern (BCC) throughout its range in the continental USA and Alaska.

Breeds elsewhere

Wood Thrush *Hylocichla mustelina*

This is a Bird of Conservation Concern (BCC) throughout its range in the continental USA and Alaska.

Breeds May 10 to Aug 31

## Probability of Presence Summary

The graphs below provide our best understanding of when birds of concern are most likely to be present in your project area. This information can be used to tailor and schedule your project activities to avoid or minimize impacts to birds. Please make sure you read and understand the FAQ "Proper Interpretation and Use of Your Migratory Bird Report" before using or attempting to interpret this report.

### Probability of Presence (■)

Each green bar represents the bird's relative probability of presence in the 10km grid cell(s) your project overlaps during a particular week of the year. (A year is represented as 12 4-week months.) A taller bar indicates a higher probability of species presence. The survey effort (see below) can be used to establish a level of confidence in the presence score. One can have higher confidence in the presence score if the corresponding survey effort is also high.

How is the probability of presence score calculated? The calculation is done in three steps:

1. The probability of presence for each week is calculated as the number of survey events in the week where the species was detected divided by the total number of survey events for that week. For example, if in week 12 there were 20 survey events and the Spotted Towhee was found in 5 of them, the probability of presence of the Spotted Towhee in week 12 is 0.25.
2. To properly present the pattern of presence across the year, the relative probability of presence is calculated. This is the probability of presence divided by the maximum probability of presence



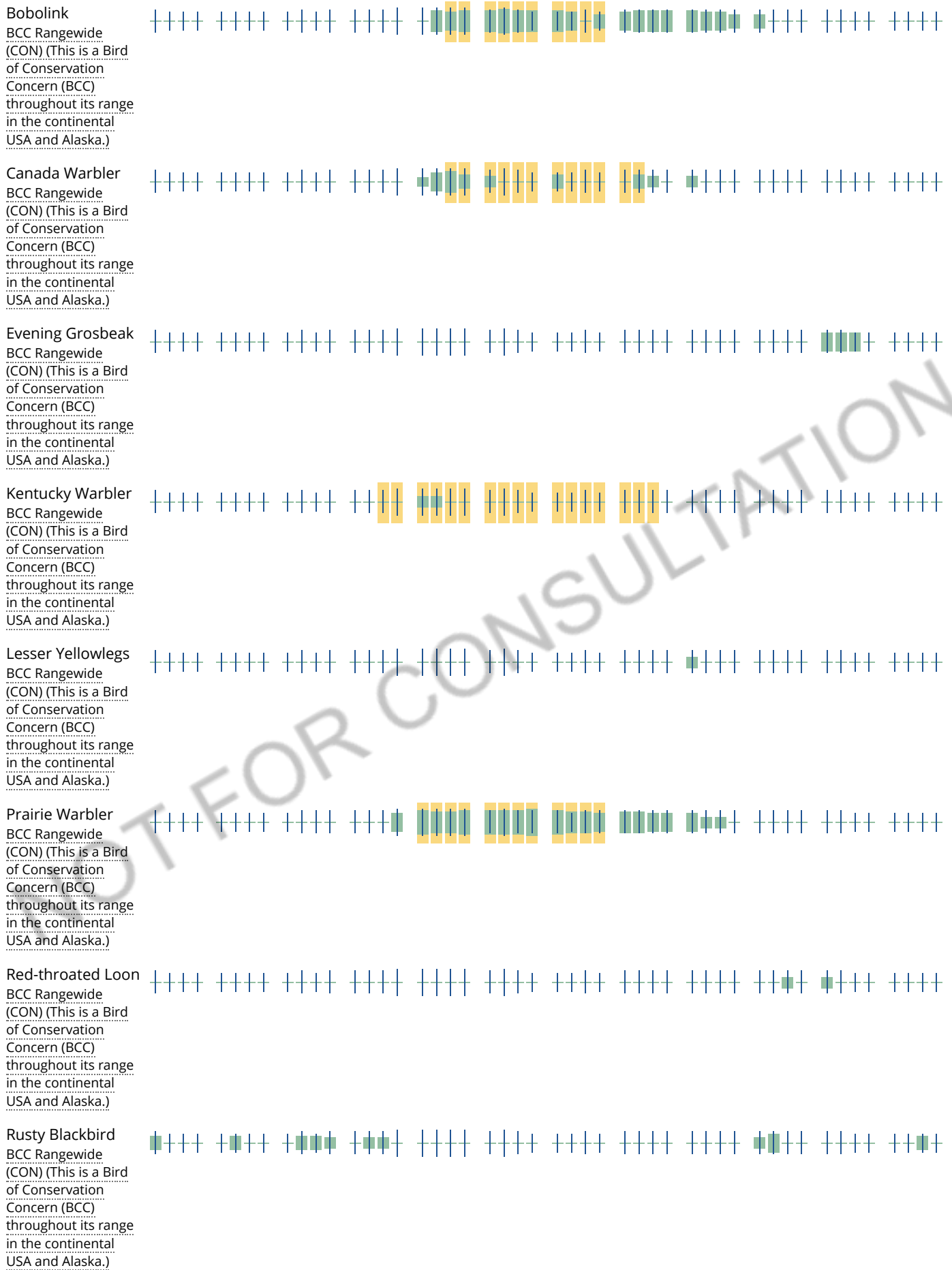

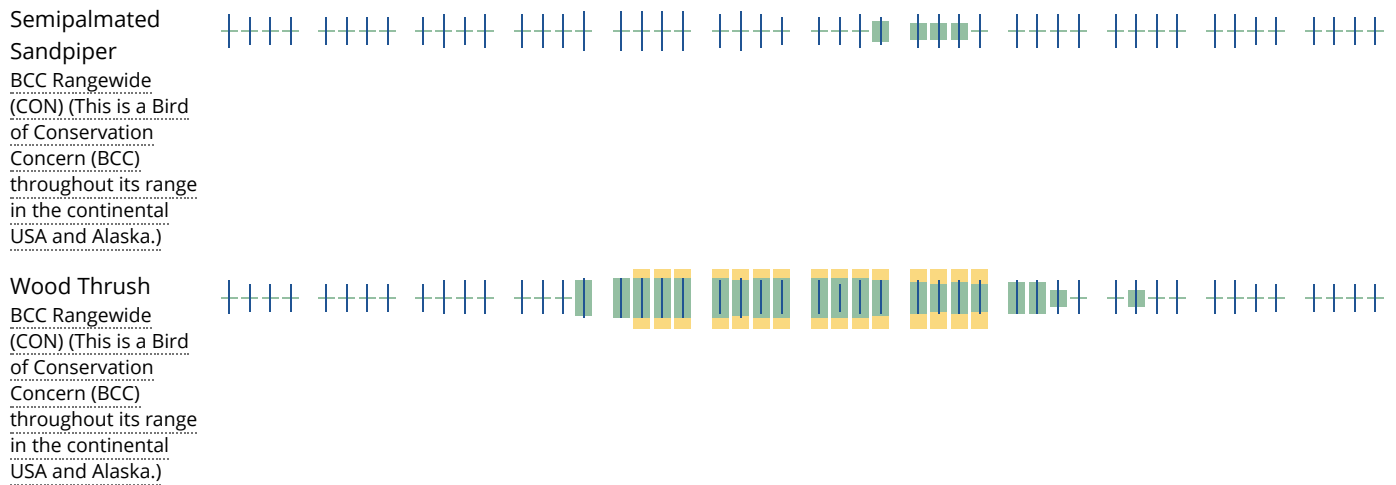

### Tell me more about conservation measures I can implement to avoid or minimize impacts to migratory birds.

[Nationwide Conservation Measures](#) describes measures that can help avoid and minimize impacts to all birds at any location year round. Implementation of these measures is particularly important when birds are most likely to occur in the project area. When birds may be breeding in the area, identifying the locations of any active nests and avoiding their destruction is a very helpful impact minimization measure. To see when birds are most likely to occur and be breeding in your project area, view the Probability of Presence Summary. [Additional measures](#) and/or [permits](#) may be advisable depending on the type of activity you are conducting and the type of infrastructure or bird species present on your project site.

### What does IPaC use to generate the migratory birds potentially occurring in my specified location?

The Migratory Bird Resource List is comprised of USFWS [Birds of Conservation Concern \(BCC\)](#) and other species that may warrant special attention in your project location.

The migratory bird list generated for your project is derived from data provided by the [Avian Knowledge Network \(AKN\)](#). The AKN data is based on a growing collection of [survey, banding, and citizen science datasets](#) and is queried and filtered to return a list of those birds reported as occurring in the 10km grid cell(s) which your project intersects, and that have been identified as warranting special attention because they are a BCC species in that area, an eagle ([Eagle Act](#) requirements may apply), or a species that has a particular vulnerability to offshore activities or development.

Again, the Migratory Bird Resource list includes only a subset of birds that may occur in your project area. It is not representative of all birds that may occur in your project area. To get a list of all birds potentially present in your project area, please visit the [AKN Phenology Tool](#).

### What does IPaC use to generate the probability of presence graphs for the migratory birds potentially occurring in my specified location?

The probability of presence graphs associated with your migratory bird list are based on data provided by the [Avian Knowledge Network \(AKN\)](#). This data is derived from a growing collection of [survey, banding, and citizen science datasets](#).

Probability of presence data is continuously being updated as new and better information becomes available. To learn more about how the probability of presence graphs are produced and how to interpret them, go the Probability of Presence Summary and then click on the "Tell me about these graphs" link.

### How do I know if a bird is breeding, wintering, migrating or present year-round in my project area?

To see what part of a particular bird's range your project area falls within (i.e. breeding, wintering, migrating or year-round), you may refer to the following resources: [The Cornell Lab of Ornithology All About Birds Bird Guide](#), or (if you are unsuccessful in locating the bird of interest there), the [Cornell Lab of Ornithology Neotropical Birds guide](#). If a bird on your migratory bird species list has a breeding season associated with it, if that bird does occur in your project area, there may be nests present at some point within the timeframe specified. If "Breeds elsewhere" is indicated, then the bird likely does not breed in your project area.

### What are the levels of concern for migratory birds?

Migratory birds delivered through IPaC fall into the following distinct categories of concern:

1. "BCC Rangewide" birds are [Birds of Conservation Concern](#) (BCC) that are of concern throughout their range anywhere within the USA (including Hawaii, the Pacific Islands, Puerto Rico, and the Virgin Islands);
2. "BCC - BCR" birds are BCCs that are of concern only in particular Bird Conservation Regions (BCRs) in the continental USA; and
3. "Non-BCC - Vulnerable" birds are not BCC species in your project area, but appear on your list either because of the [Eagle Act](#) requirements (for eagles) or (for non-eagles) potential susceptibilities in offshore areas from certain types of development or activities (e.g. offshore energy development or longline fishing).

Although it is important to try to avoid and minimize impacts to all birds, efforts should be made, in particular, to avoid and minimize impacts to the birds on this list, especially eagles and BCC species of rangewide concern. For more information on conservation measures you can implement to help avoid and minimize migratory bird impacts and requirements for eagles, please see the FAQs for these topics.

### Details about birds that are potentially affected by offshore projects

For additional details about the relative occurrence and abundance of both individual bird species and groups of bird species within your project area off the Atlantic Coast, please visit the [Northeast Ocean Data Portal](#). The Portal also offers data and information about other taxa besides birds that may be helpful to you in your project review. Alternately, you may download the bird model results files underlying the portal maps through the [NOAA NCCOS Integrative Statistical Modeling and Predictive Mapping of Marine Bird Distributions and Abundance on the Atlantic Outer Continental Shelf](#) project webpage.

Bird tracking data can also provide additional details about occurrence and habitat use throughout the year, including migration. Models relying on survey data may not include this information. For additional information on marine bird tracking data, see the [Diving Bird Study](#) and the [nanotag studies](#) or contact [Caleb Spiegel](#) or [Pam Loring](#).

### What if I have eagles on my list?

If your project has the potential to disturb or kill eagles, you may need to [obtain a permit](#) to avoid violating the Eagle Act should such impacts occur.

### Proper Interpretation and Use of Your Migratory Bird Report

The migratory bird list generated is not a list of all birds in your project area, only a subset of birds of priority concern. To learn more about how your list is generated, and see options for identifying what other birds may be in your project area, please see the FAQ "What does IPaC use to generate the migratory birds potentially occurring in my specified location". Please be aware this report provides the "probability of presence" of birds within the 10 km grid cell(s) that overlap your project; not your exact project footprint. On the graphs provided, please also look carefully at the survey effort (indicated by the black vertical bar) and for the existence of the "no data" indicator (a red horizontal bar). A high survey effort is the key component. If the survey effort is high, then the probability of presence score can be viewed as more dependable. In contrast, a low survey effort bar or no data bar means a lack of data and, therefore, a lack of certainty about presence of the species. This list is not perfect; it is simply a starting point for identifying what birds of concern have the potential to be in your project area, when they might be there, and if they might be breeding (which means nests might be present). The list helps you know what to look for to

confirm presence, and helps guide you in knowing when to implement conservation measures to avoid or minimize potential impacts from your project activities, should presence be confirmed. To learn more about conservation measures, visit the FAQ "Tell me about conservation measures I can implement to avoid or minimize impacts to migratory birds" at the bottom of your migratory bird trust resources page.

## Facilities

### National Wildlife Refuge lands

Any activity proposed on lands managed by the [National Wildlife Refuge](#) system must undergo a 'Compatibility Determination' conducted by the Refuge. Please contact the individual Refuges to discuss any questions or concerns.

THERE ARE NO REFUGE LANDS AT THIS LOCATION.

### Fish hatcheries

THERE ARE NO FISH HATCHERIES AT THIS LOCATION.

### Wetlands in the National Wetlands Inventory

Impacts to [NWI wetlands](#) and other aquatic habitats may be subject to regulation under Section 404 of the Clean Water Act, or other State/Federal statutes.

For more information please contact the Regulatory Program of the local [U.S. Army Corps of Engineers District](#).

WETLAND INFORMATION IS NOT AVAILABLE AT THIS TIME

This can happen when the National Wetlands Inventory (NWI) map service is unavailable, or for very large projects that intersect many wetland areas. Try again, or visit the [NWI map](#) to view wetlands at this location.

#### Data limitations

The Service's objective of mapping wetlands and deepwater habitats is to produce reconnaissance level information on the location, type and size of these resources. The maps are prepared from the analysis of high altitude imagery. Wetlands are identified based on vegetation, visible hydrology and geography. A margin of error is inherent in the use of imagery; thus, detailed on-the-ground inspection of any particular site may result in revision of the wetland boundaries or classification established through image analysis.

The accuracy of image interpretation depends on the quality of the imagery, the experience of the image analysts, the amount and quality of the collateral data and the amount of ground truth verification work conducted. Metadata should be consulted to determine the date of the source imagery used and any mapping problems.

Wetlands or other mapped features may have changed since the date of the imagery or field work. There may be occasional differences in polygon boundaries or classifications between the information depicted on the map and the actual conditions on site.

### **Data exclusions**

Certain wetland habitats are excluded from the National mapping program because of the limitations of aerial imagery as the primary data source used to detect wetlands. These habitats include seagrasses or submerged aquatic vegetation that are found in the intertidal and subtidal zones of estuaries and nearshore coastal waters. Some deepwater reef communities (coral or tubercid worm reefs) have also been excluded from the inventory. These habitats, because of their depth, go undetected by aerial imagery.

### **Data precautions**

Federal, state, and local regulatory agencies with jurisdiction over wetlands may define and describe wetlands in a different manner than that used in this inventory. There is no attempt, in either the design or products of this inventory, to define the limits of proprietary jurisdiction of any Federal, state, or local government or to establish the geographical scope of the regulatory programs of government agencies. Persons intending to engage in activities involving modifications within or adjacent to wetland areas should seek the advice of appropriate federal, state, or local agencies concerning specified agency regulatory programs and proprietary jurisdictions that may affect such activities.

NOT FOR CONSULTATION

**Appendix D**  
**MS4 System Maps**



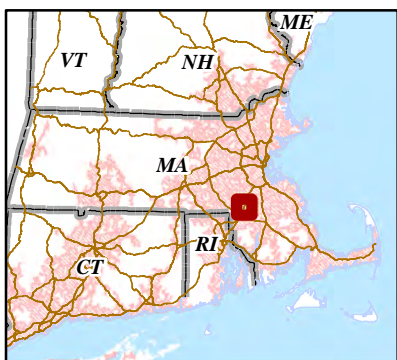
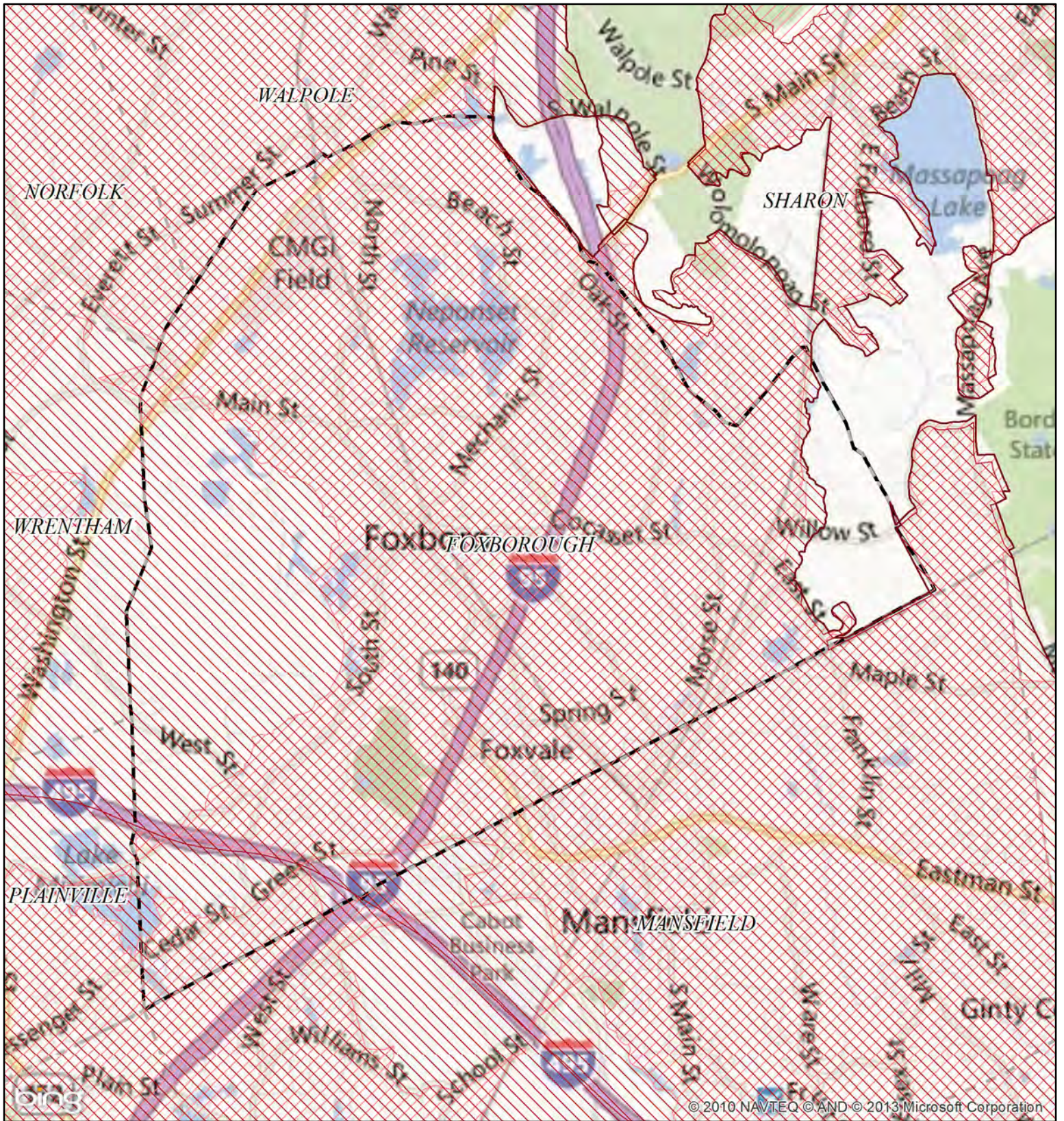

NPDES Phase II Stormwater Program  
Automatically Designated MS4 Areas

**Foxborough MA**

Regulated Area:

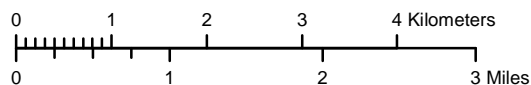

Town Population: 16865  
Regulated Population: 16702  
(Populations estimated from 2010 Census)



●  
Urbanized Areas, Town Boundaries:  
US Census (2000, 2010)  
Base map © 2013 Microsoft Corporation  
and its data suppliers



# Foxborough Drainage System

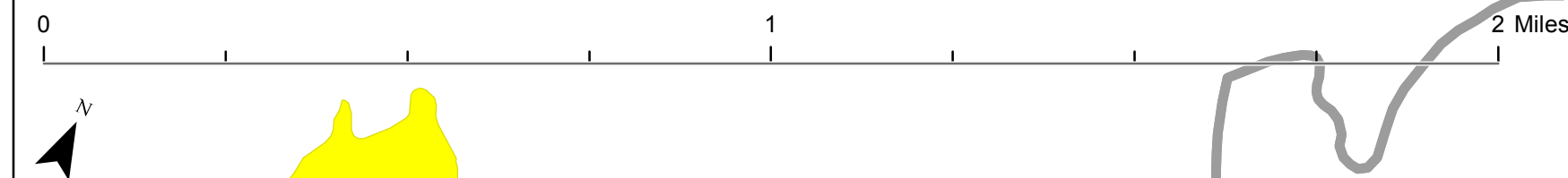

## Legend

- ▲ Outfall
  - Catch Basin
  - Basin Box
  - Drain Manhole
  - Leaching System
  - ▲ Inlet
  - ▲ Outlet
  - Pipe Ending
  - Sewer Manhole
  - Gravity Sewer
  - - - Force Main Sewer
  - Drain Pipe
  - Town Line
  - ▒ Detention Basin
  - ▒ Retention Basin
  - ▒ Swale
  - ▭ Catchment Delineations
  - ▭ Watersheds
- Impaired Rivers**
- Category**
- 2 - Attaining some uses; other uses not assessed
  - 3 - No uses assessed
  - 4A - Impaired - TMDL is completed
  - 4C - Impairment not caused by a pollutant
  - 5 - Impaired - TMDL required
- Impaired Lakes**
- Category**
- 2 - Attaining some uses; other uses not assessed
  - 3 - No uses assessed
  - 4A - Impaired - TMDL is completed
  - 4C - Impairment not caused by a pollutant
  - 5 - Impaired - TMDL required

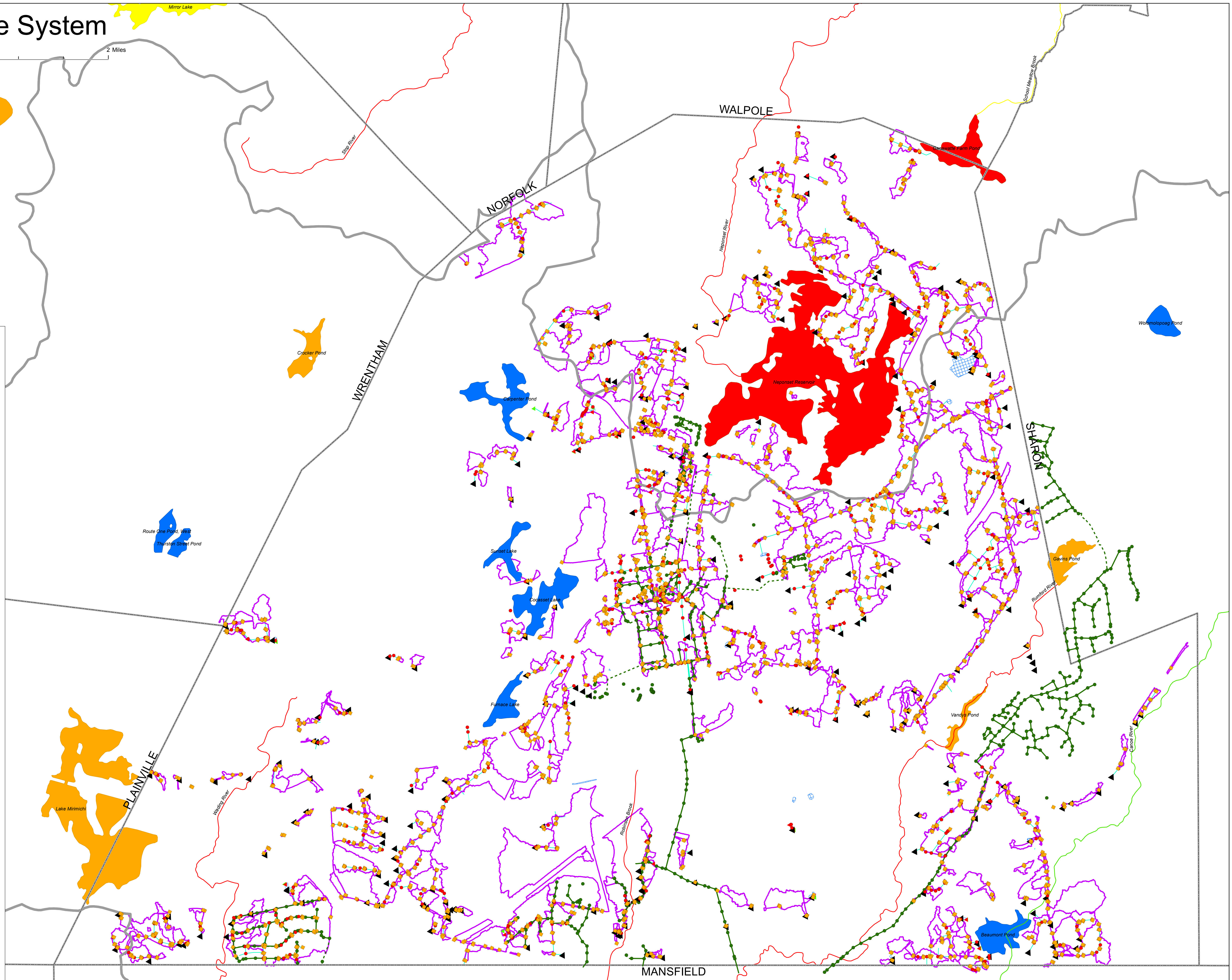

**Appendix E**  
**Standard Operating Procedures**



# Massachusetts Small MS4 General Permit

## Standard Operating Procedures

### Town of Foxborough, Massachusetts

June 30, 2020



### Index of Standard Operating Procedures

No.	Standard Operating Procedure Name	Form(s) Included	Related SOPs
1	Dry Weather Outfall Inspection	Dry Weather Outfall Inspection Survey	2, 10, 13
2	Wet Weather Outfall Inspection	Wet Weather Outfall Inspection Survey	1, 10, 13
3	Catch Basin Inspection and Cleaning	Catch Basin Inspection Form	16
4	Spill Response and Cleanup Procedures	Spill Response and Cleanup Contact List	-
5	Construction Site Inspection Procedures	Construction Site Stormwater Inspection Report	9
6	Erosion and Sedimentation Control	Erosion and Sedimentation Control Form	5, 9
7	Fuel and Oil Handling Procedures	Fuel Delivery Checklist	4
9	Inspecting Constructed BMPs	Inspecting Constructed BMPs Form	-
10	Locating Illicit Discharges	Illicit Discharge Incident Tracking Sheet	1, 2, 3, 13, 15
11	Oil/Water Separator Maintenance	Quarterly Inspection Form	4
12	Storage and Use of Pesticides and Fertilizer	-	4, 17
13	Water Quality Screening in the Field	Water Quality Screening Form	1, 2, 3, 10
15	Private Drainage Connections	Private Drainage Inspection Form	-
16	Street and Parking Lots	Street Sweeping Log	21
17	Hazardous Materials Storage and Handling	-	4
18	Winter Road Maintenance	-	4, 21
19	Operations and Maintenance of Parks and Opens Spaces	Inventory of Municipal Parks and Opens Spaces	7, 12, 16, 18, 21
20	Operations and Maintenance of Municipal Buildings and Facilities	Inventory of Municipal Buildings and Facilities	4, 7, 12, 16, 17
21	Operations and Maintenance of Municipal Vehicles and Equipment	Inventory of Municipal Vehicles and Equipment	4, 7, 17

## **SOP 1: DRY WEATHER OUTFALL INSPECTION**

### *Introduction*

Outfalls from an engineered storm drain system can be in the form of pipes or ditches. Under current and pending regulations, it is important to inspect and document water quality from these outfalls under both dry weather and wet weather conditions. SOP 2, “Wet Weather Outfall Inspection”, covers the objectives of that type of inspection. This SOP discusses the dry weather inspection objectives, and how they differ from wet weather inspection objectives.

During a dry weather period, it is anticipated that minimal flow from stormwater outfalls will be observed. Therefore, dry weather inspections aim to characterize any/all flow observed during a dry weather period and identify potential source(s) of an illicit discharge through qualitative testing; further described in SOP 13, “Water Quality Screening in the Field”.

### *Objectives of Dry Weather Inspections*

A dry weather period is a time interval during which less than 0.1 inch of rain is observed across a minimum of 72 hours. Unlike wet weather sampling, dry weather inspections are not intended to capture a “first flush” of stormwater discharge, rather they are intended to identify any/all discharges from a stormwater outfall during a period without recorded rainfall. The objective of inspections during a dry weather period is to characterize observed discharges and facilitate detection of illicit discharges.

### *Visual Condition Assessment*

The attached Dry Weather Outfall Inspection Survey is a tool to assist in documenting observations related to the both quantitative and qualitative characteristics of any/all flows conveyed by the structure during a dry period.

For any visual observation discharge from a stormwater outfall, an investigation into the pollution source should occur, but the following are often true:

1. Foam: indicator of upstream vehicle washing activities, or an illicit discharge.
2. Oil sheen: result of a leak or spill.
3. Cloudiness: indicator of suspended solids such as dust, ash, powdered chemicals and ground up materials.
4. Color or odor: Indicator of raw materials, chemicals, or sewage.
5. Excessive sediment: indicator of disturbed earth of other unpaved areas lacking adequate erosion control measures.
6. Sanitary waste and optical enhancers (fluorescent dyes added to laundry detergent): indicators of illicit discharge.
7. Orange staining: indicator of high mineral concentrations.

Both bacteria and petroleum can create a sheen on the water surface. The source of the sheen can be differentiated by disturbing it, such as with a pole. A sheen caused by oil will remain intact and move in a swirl pattern; a sheen caused by bacteria will separate and appear “blocky”. Bacterial or naturally occurring sheens are usually silver or relatively dull in color and will break up into a number of small patches of sheen. The cause may be presence of iron, decomposition of organic material or presence of certain bacteria. Bacterial sheen is not a pollutant but should be noted.

Many of these observations are indicators of an illicit discharge. Examples of illicit discharges include: cross-connections of sewer services to engineered storm drain systems; leaking septic systems; intentional discharge of pollutants to catch basins; combined sewer overflows; connected floor drains; and sump pumps connected to the system (under some circumstances). Additional guidelines for illicit discharge investigations are included in SOP 10, “Locating Illicit Discharges”. If dry weather flow is present at the outfall, and the flow does not appear to be an obvious illicit discharge (e.g. flow is clear, odorless, etc.) attempt to identify the source of flow (e.g. intermittent stream, wetlands drainage, etc.) and document the discharge for future comparison.

Although many of the observations are indicators of illicit discharge it should be noted that several of these indicators may also occur naturally. Orange staining may be the result of naturally occurring iron, and thus unrelated to pollution. Foam can be formed when the physical characteristics of water are altered by the presence of organic materials. Foam is typically found in waters with high organic content such as bog lakes, streams that originate from bog lakes, productive lakes, wetlands, or woody areas. To determine the difference between natural foam and foam cause by pollution, consider the following:

1. Wind direction or turbulence: natural foam occurrences on the beach coincide with onshore winds. Often, foam can be found along a shoreline and/or on open waters during windy days. Natural occurrences in rivers can be found downstream of a turbulent site.
2. Proximity to a potential pollution source: some entities including the textile industry, paper production facilities, oil industries, and fire fighting activities work with materials that cause foaming in water. If these materials are released to a water body in large quantities, they can cause foaming. Also, the presence of silt in water, such as from a construction site can cause foam.
3. Feeling: natural foam is typically persistent, light, not slimy to the touch.
4. Presence of decomposing plants or organic material in the water.

Optical enhancers, fluorescent dyes added to laundry detergent, are typically detected through the use of clean, white cotton pads placed within the discharge for several days, dried then viewed under a UV light. If the cotton pad displays fluorescent patches, optical enhancers are present. Optical enhancers are occasionally visible as a bluish-purple haze on the water surface; however the testing method should be used to confirm the presence of optical enhancers.

The Dry Weather Outfall Inspection Survey includes fields where these and other specific observations can be noted. The inspector shall indicate the presence of a specific water quality indicator or parameter

by marking “Yes”. If “Yes” is marked, provide additional details in the comments section. If the indicator in question is not present, mark “No”.

Within the comments section, provide additional information with regard to recorded precipitation totals, or more detailed descriptions of observations made during the inspection and corrective actions taken.

### *Measuring Water Quality*

Based on the results of the Visual Condition Assessment, it may be necessary to collect additional data about water quality. Water quality samples can be in the form of screening using field test kits and instrumentation, or by discrete analytical samples processed by a laboratory.

Information on selecting and using field test kits and instrumentation is included in SOP 13, “Water Quality Screening in the Field.” The Inspection Survey also provides values for what can be considered an appropriate benchmark for a variety of parameters that can be evaluated in the field.

If the results of screening using field test kits indicate that the outfall’s water quality exceeds the benchmarks provided, collection of discrete analytical samples should be considered.

### *Analytical Sample Collection*

Sample collection methods may vary based on specific outfall limitations, but shall follow test procedures outlined in 40 CFR 136. A discrete manual or grab sample can classify water at a distinct point in time. These samples are easily collected and used primarily when the water quality of the discharge is expected to be homogeneous, or unchanging, in nature. A flow-weighted composite sample will classify water quality over a measured period of time. These samples are used when the water quality of the discharge is expected to be heterogeneous, or fluctuating, in nature. Grab samples are more common for dry weather outfall inspections due to the time-sensitive nature of the process.

Protocols for collecting a grab sample shall include the following:

1. Do not eat, drink or smoke during sample collection and processing.
2. Do not collect or process samples near a running vehicle.
3. Do not park vehicles in the immediate sample collection area, including both running and non-running vehicles.
4. Always wear clean, powder-free nitrile gloves when handling sample containers and lids.
5. Never touch the inside surface of a sample container or lid, even with gloved hands.
6. Never allow the inner surface of a sample container or lid to be contacted by any material other than the sample water.
7. Collect samples while facing upstream and so as not to disturb water or sediments in the outfall pipe or ditch.
8. Do not overfill sample containers, and do not dump out any liquid in them. Liquids are often added to sample containers intentionally by the analytical laboratory as a preservative or for pH adjustment.



9. Slowly lower the bottle into the water to avoid bottom disturbance and stirring up sediment.
10. Do not allow any object or material to fall into or contact the collected water sample.
11. Do not allow rainwater to drip from rain gear or other surfaces into sample containers.
12. Replace and tighten sample container lids immediately after sample collection.
13. Accurately label the sample with the time and location.
14. Document on the Wet Weather Outfall Inspection Survey that analytical samples were collected, specify parameters, and note the sample time on the Inspection Survey. This creates a reference point for samples.

### *Analytical Sample Quality Control and Assurance*

Upon completion of successful sample collection, the samples must be sent or delivered to a MassDEP-approved laboratory for analytical testing. Quality control and assurance are important to ensuring accurate analytical test results.

Sample preservation is required to prevent contaminate degradation between sampling and analysis, and should be completed in accordance with 40 CFR 136.3.

Maximum acceptable holding times are also specified for each analytical method in 40 CFR 136.3. Holding time is defined as the period of time between sample collection and extraction for analysis of the sample at the laboratory. Holding time is important because prompt laboratory analysis allows the laboratory to review the data and if analytical problems are found, re-analyze the affected samples within the holding times.

Chain of custody forms are designed to provide sample submittal information and document transfers of sample custody. The forms are typically provided by the laboratory and must be completed by the field sampling personnel for each sample submitted to the lab for analysis. The document must be signed by both the person releasing the sample and the person receiving the sample every time the sample changes hands. The sampling personnel shall keep one copy of the form and send the remaining copies to the laboratory with the samples. Custody seals, which are dated, signed and affixed to the sample container, may be used if the samples are shipped in a cooler via courier or commercial overnight shipping.

### *Attachments*

1. Dry Weather Outfall Inspection Survey

### *Related Standard Operating Procedures*

1. SOP 2, Wet Weather Outfall Inspection
2. SOP 10, Locating Illicit Discharges
3. SOP 13, Water Quality Screening in the Field

**Outfall ID:** \_\_\_\_\_ **Town:** \_\_\_\_\_  
**Inspector:** \_\_\_\_\_ **Date:** \_\_\_\_\_  
**Street Name** \_\_\_\_\_  
**Last rainfall event** \_\_\_\_\_



**DRY WEATHER OUTFALL INSPECTION SURVEY**

<b>Type of Outfall (check one):</b>		<b>Pipe Outfall</b> <input type="checkbox"/>	<b>Open Swale Outfall</b> <input type="checkbox"/>
<b>Outfall Label:</b>		<b>Stencil</b> <input type="checkbox"/>	<b>Ground Inset</b> <input type="checkbox"/> <b>Sign</b> <input type="checkbox"/> <b>None</b> <input type="checkbox"/> <b>Other</b> _____
<b>Pipe Material:</b>	Concrete <input type="checkbox"/>	<b>Pipe Condition:</b>	Good <input type="checkbox"/> Poor <input type="checkbox"/>
	Corrugated metal <input type="checkbox"/>		Fair <input type="checkbox"/> Crumbling <input type="checkbox"/>
	Clay Tile <input type="checkbox"/>		
	Plastic <input type="checkbox"/>		
Other: _____ <input type="checkbox"/>			
<b>Swale Material:</b>	Paved (asphalt) <input type="checkbox"/>	<b>Swale Condition:</b>	Good <input type="checkbox"/> Poor <input type="checkbox"/>
	Concrete <input type="checkbox"/>		Fair <input type="checkbox"/> Crumbling <input type="checkbox"/>
	Earthen <input type="checkbox"/>		
	Stone <input type="checkbox"/>		
	Other: _____ <input type="checkbox"/>		
<b>Shape of Pipe/Swale (check one)</b>			
 <input type="checkbox"/>		 <input type="checkbox"/>	
 <input type="checkbox"/>		 <input type="checkbox"/>	
<b>Rounded Pipe/Swale</b>		<b>Rectangular Pipe/Swale</b>	<b>Triangular Swale</b>
<b>Trapezoidal Swale</b>			
<b>Pipe Measurements:</b>		<b>Swale Measurements:</b>	
Inner Dia. (in): d= _____		Swale Width (in): T= _____	
Outer Dia. (in): D= _____		Flow Width (in): t = _____	
Pipe Width (in): T= _____		Swale Height (in): H= _____	
Pipe Height (in): H= _____		Flow Height (in): h= _____*	
Flow Width (in): h= _____*		Bottom Width (in): b= _____	
		<b>Is there a headwall?</b>	
		Yes <input type="checkbox"/> No <input type="checkbox"/>	
		<b>Condition:</b>	
		Good <input type="checkbox"/> Poor <input type="checkbox"/>	
		Fair <input type="checkbox"/> Crumbling <input type="checkbox"/>	
		<b>Location Sketch</b>	
<b>Description of Flow:</b> Heavy <input type="checkbox"/> Moderate <input type="checkbox"/> Trickling <input type="checkbox"/> Dry <input type="checkbox"/>			
<b>If the outlet is submerged check yes and indicate approximate height of water above the outlet invert. h above invert (in):</b>		<b>Circle All Materials Present:</b>	
Odor: Yes <input type="checkbox"/> No <input type="checkbox"/>		Rip rap	
Optical enhancers suspected? Yes <input type="checkbox"/> No <input type="checkbox"/>		Excessive sediment	
Has channelization occurred? Yes <input type="checkbox"/> No <input type="checkbox"/>		Foam	
Has scouring occurred below the outlet? Yes <input type="checkbox"/> No <input type="checkbox"/>		Sanitary Waste	
<b>Required Maintenance:</b>		Orange Staining	
Tree Work		Sheen: Bacterial	
Ditch Work		Sheen: Petroleum	
Structural Corrosion		Floatables	
N/A		Algae	
Remove Trash/Debris		Excessive Vegetation	
Blocked Pipe			
Erosion at Structure			
Other			
<b>Comments:</b>			

## SOP 2: WET WEATHER OUTFALL INSPECTION

### *Introduction*

Outfalls from an engineered storm drain system can be in the form of pipes or ditches. Under current and pending regulations, it is important to inspect and document water quality from these outfalls under both dry weather and wet weather conditions. SOP 1, “Dry Weather Outfall Inspection”, covers the objectives of that type of inspection. This SOP discusses wet weather inspection objectives and how they differ from dry weather inspection objectives. The primary difference is that wet weather inspection aims to describe and evaluate the first flush of stormwater discharged from an outfall during a storm, representing the maximum pollutant load managed by receiving water.

### *Definition of Wet Weather*

A storm is considered a representative wet weather event if greater than 0.1 inch of rain falls and occurs at least 72 hours after the previously measurable (greater than 0.1 inch of rainfall) storm event. In some watersheds, based on the amount of impervious surface present, increased discharge from an outfall may not result from 0.1 inch of rain. An understanding of how outfalls respond to different events will develop as the inspection process proceeds over several months, allowing the inspectors to refine an approach for inspections.

Ideally, the evaluation and any samples collected should occur within the first 30 minutes of discharge to reflect the first flush or maximum pollutant load.

Typical practice is to prepare for a wet weather inspection event when weather forecasts show a 40% chance of rain or greater. If the inspector intends to collect analytical samples, coordination with the laboratory for bottleware and for sample drop-off needs to occur in advance.

### *Visual Condition Assessment*

The attached Wet Weather Outfall Inspection Survey should be used to document observations related to the quality of stormwater conveyed by the structure. Observations such as the following can indicate sources of pollution within the storm drain system:

- Oil sheen
- Discoloration
- Trash and debris

For any visual observation of pollution in a stormwater outfall discharge, an investigation into the pollution source should occur, but the following are often true:

1. Foam: indicator of upstream vehicle washing activities, or an illicit discharge.
2. Oil sheen: result of a leak or spill.

3. Cloudiness: indicator of suspended solids such as dust, ash, powdered chemicals and ground up materials.
4. Color or odor: Indicator of raw materials, chemicals, or sewage.
5. Excessive sediment: indicator or disturbed earth of other unpaved areas lacking adequate erosion control measures.
6. Sanitary waste and optical enhancers (fluorescent dyes added to laundry detergent): indicators of illicit discharge.
7. Orange staining: indicator of high mineral concentrations.

Many of these observations are indicators of an illicit discharge. Examples of illicit discharges include: cross-connections of sewer services to engineered storm drain systems; leaking septic systems; intentional discharge of pollutants to catch basins; combined sewer overflows; connected floor drains; and sump pumps connected to the system (under some circumstances). Additional guidelines for illicit discharge investigations are included in SOP 10, "Locating Illicit Discharges".

Although many of the observations are indicators of illicit discharge it should be noted that several of these indicators may also occur naturally. Orange staining may be the result of naturally occurring iron, and thus unrelated to pollution. Foam can be formed when the physical characteristics of water are altered by the presence of organic materials. Foam is typically found in waters with high organic content such as bog lakes, streams that originate from bog lakes, productive lakes, wetlands, or woody areas. To determine the difference between natural foam and foam cause by pollution, consider the following:

1. Wind direction or turbulence: natural foam occurrences on the beach coincide with onshore winds. Often, foam can be found along a shoreline and/or on open waters during windy days. Natural occurrences in rivers can be found downstream of a turbulent site.
2. Proximity to a potential pollution source: some entities including the textile industry, paper production facilities, oil industries, and fire fighting activities work with materials that cause foaming in water. If these materials are released to a water body in large quantities, they can cause foaming. Also, the presence of silt in water, such as from a construction site can cause foam.
3. Feeling: natural foam is typically persistent, light, not slimy to the touch.
4. Presence of decomposing plants or organic material in the water.

Both bacteria and petroleum can create a sheen on the water surface. The source of the sheen can be differentiated by disturbing it, such as with a pole. A sheen caused by oil will remain intact and move in a swirl pattern; a sheen caused by bacteria will separate and appear "blocky". Bacterial or naturally occurring sheens are usually silver or relatively dull in color and will break up into a number of small patches of sheen. The cause may be presence of iron, decomposition of organic material or presence of certain bacteria. Bacterial sheen is not a pollutant but should be noted.

Optical enhancers, fluorescent dyes added to laundry detergent, are typically detected through the use of clean, white cotton pads placed within the discharge for several days, dried then viewed under a UV light. If the cotton pad displays fluorescent patches, optical enhancers are present. Optical enhancers are occasionally visible as a bluish-purple haze on the water surface; however the testing method should be used to confirm the presence of optical enhancers.

The Wet Weather Outfall Inspection Survey includes fields where these and other specific observations can be noted. The inspector shall indicate the presence of a specific water quality indicator or parameter by marking “Yes”. If “Yes” is marked, provide additional details in the comments section. If the indicator in question is not present mark “No”.

Within the comments section, provide additional information with regard to recorded precipitation totals, or more detailed descriptions of observations made during the inspection and corrective actions taken.

### *Measuring Water Quality*

Based on the results of the Visual Condition Assessment, it may be necessary to collect additional data about water quality. Water quality samples can be in the form of screening using field test kits or by discrete analytical samples processed by a laboratory.

Information on how to use field test kits is included in SOP 13, “Water Quality Screening with Field Test Kits”, and the Wet Weather Outfall Inspection Survey includes fields to document the results of such screening. The Inspection Survey also provides values for what can be considered an appropriate benchmark for a variety of parameters that can be evaluated with field test kits.

If the results of screening using field test kits indicate that the outfall’s water quality exceeds the benchmarks provided, collection of discrete analytical samples should be considered.

### *Analytical Sample Collection*

Sample collection methods may vary based on specific outfall limitations but shall follow test procedures outlined in 40 CFR 136. A discrete manual or grab sample can classify water at a distinct point in time. These samples are easily collected and used primarily when the water quality of the discharge is expected to be homogeneous, or unchanging, in nature. A flow-weighted composite sample will classify water quality over a measured period of time. These samples are used when the water quality of the discharge is expected to be heterogeneous, or fluctuating, in nature. Grab samples are more common for wet weather outfall inspections due to the time-sensitive nature of the process.

Protocols for collecting a grab sample shall include the following:

1. Do not eat, drink or smoke during sample collection and processing.
2. Do not collect or process samples near a running vehicle.
3. Do not park vehicles in the immediate sample collection area, including both running and non-running vehicles.
4. Always wear clean, powder-free nitrile gloves when handling sample containers and lids.
5. Never touch the inside surface of a sample container or lid, even with gloved hands.
6. Never allow the inner surface of a sample container or lid to be contacted by any material other than the sample water.
7. Collect samples while facing upstream and so as not to disturb water or sediments in the outfall pipe or ditch.

8. Do not overfill sample containers, and do not dump out any liquid in them. Liquids are often added to sample containers intentionally by the analytical laboratory as a preservative or for pH adjustment.
9. Slowly lower the bottle into the water to avoid bottom disturbance and stirring up sediment.
10. Do not allow any object or material to fall into or contact the collected water sample.
11. Do not allow rainwater to drip from rain gear or other surfaces into sample containers.
12. Replace and tighten sample container lids immediately after sample collection.
13. Accurately label the sample with the time and location.
14. Document on the Wet Weather Outfall Inspection Survey that analytical samples were collected, specify parameters, and note the sample time on the Inspection Survey. This creates a reference point for samples.

### *Analytical Sample Quality Control and Assurance*

Upon completion of successful sample collection, the samples must be sent or delivered to a MassDEP-approved laboratory for analytical testing. Quality control and assurance are important to ensuring accurate analytical test results.

Sample preservation is required to prevent contaminant degradation between sampling and analysis and should be completed in accordance with 40 CFR 136.3.

Maximum acceptable holding times are also specified for each analytical method in 40 CFR 136.3. Holding time is defined as the period of time between sample collection and extraction for analysis of the sample at the laboratory. Holding time is important because prompt laboratory analysis allows the laboratory to review the data and if analytical problems are found, re-analyze the affected samples within the holding times.

Chain of custody forms are designed to provide sample submittal information and document transfers of sample custody. The forms are typically provided by the laboratory and must be completed by the field sampling personnel for each sample submitted to the lab for analysis. The document must be signed by both the person releasing the sample and the person receiving the sample every time the sample changes hands. The sampling personnel shall keep one copy of the form and send the remaining copies to the laboratory with the samples. Custody seals, which are dated, signed and affixed to the sample container, may be used if the samples are shipped in a cooler via courier or commercial overnight shipping.

### *Attachments*

1. Wet Weather Outfall Inspection Survey

### *Related Standard Operating Procedures*

1. SOP 1, Dry Weather Outfall Inspection
2. SOP 10, Locating Illicit Discharges
3. SOP 13, Water Quality Screening in the Field

**Outfall I.D.:** \_\_\_\_\_ **Date:** \_\_\_\_\_  
**Inspector:** \_\_\_\_\_  
**Time of Inspection:** \_\_\_\_\_  
**Street Name** \_\_\_\_\_  
**Last rainfall event** \_\_\_\_\_



**WET WEATHER OUTFALL INSPECTION SURVEY**

Visual Inspection:	Yes	No	Comments (Include probable source of observed contamination):
Color	<input type="checkbox"/>	<input type="checkbox"/>	
Odor	<input type="checkbox"/>	<input type="checkbox"/>	
Turbidity	<input type="checkbox"/>	<input type="checkbox"/>	
Excessive Sediment	<input type="checkbox"/>	<input type="checkbox"/>	
Sanitary Waste	<input type="checkbox"/>	<input type="checkbox"/>	
Pet Waste	<input type="checkbox"/>	<input type="checkbox"/>	
Floatable Solids	<input type="checkbox"/>	<input type="checkbox"/>	
Oil Sheen	<input type="checkbox"/>	<input type="checkbox"/>	
Bacterial Sheen	<input type="checkbox"/>	<input type="checkbox"/>	
Foam	<input type="checkbox"/>	<input type="checkbox"/>	
Algae	<input type="checkbox"/>	<input type="checkbox"/>	
Orange Staining	<input type="checkbox"/>	<input type="checkbox"/>	
Excessive Vegetation	<input type="checkbox"/>	<input type="checkbox"/>	
Optical Enhancers	<input type="checkbox"/>	<input type="checkbox"/>	
Other _____			

Sample Parameters	Analytical Test Method	Benchmark*	Field Screening Result	Full Analytical?
Ammonia <sup>1</sup>	EPA 350.2/SM4500-NH3C	>50.0 mg/L		<input type="checkbox"/> Yes <input type="checkbox"/> No
Specific Conductance <sup>1</sup>	SM 2510B	>2,000		<input type="checkbox"/> Yes <input type="checkbox"/> No
Detergents & Surfactants <sup>2</sup>	EPA 425.1/SM5540C	> 0.25 mg/L		<input type="checkbox"/> Yes <input type="checkbox"/> No
Fluoride <sup>2</sup>	EPA 300.0	>0.25 mg/L		<input type="checkbox"/> Yes <input type="checkbox"/> No
pH <sup>1</sup>	EPA 150.1/SM 4500H	<5		<input type="checkbox"/> Yes <input type="checkbox"/> No
Potassium <sup>1</sup>	EPA 200.7	>20 mg/L		<input type="checkbox"/> Yes <input type="checkbox"/> No

**Comments:** \_\_\_\_\_

<sup>1</sup> – *Illicit Discharge Detection and Elimination: A Guidance Manual for Program Development and Technical Assessments*, Center for Watershed Protection and Robert Pitt of University of Alabama, 2004, p. 134, Table 45.

<sup>2</sup> – *Appendix I – Field Measurements, Benchmarks and Instrumentation*, Draft Massachusetts North Coastal Small MS4 General Permit, 2009.

# SOP 3: Catch Basin Inspection and Cleaning

## Introduction

Catch basins help minimize flooding and protect water quality by removing trash, sediment, decaying debris, and other solids from stormwater runoff. These materials are retained in a sump below the invert of the outlet pipe (older catch basins may not have a sump). Catch basin cleaning reduces foul odors, prevents clogs in the storm drain system, and reduces the loading of trash, suspended solids, nutrients, bacteria, and other pollutants to receiving waters. The goal of this written Standard Operating Procedure (SOP) is to provide guidance to municipal employees on catch basin inspection and cleaning to reduce the discharge of pollutants from the MS4. If services are contracted, this SOP should be provided to the contractor. The contract should specify that the contractor is responsible for compliance with all applicable laws.

This SOP can also be used for inspection of catch basins or manholes for the purpose of conducting catchment investigations as part of the municipality's Illicit Discharge Detection and Elimination program.

The Department of Public Works performs routine inspections, cleaning, and maintenance of the approximately 2,223 catch basins that are located within the MS4 regulated area. The Town of Foxborough will include an optimization plan for catch basin cleaning and inspection in its annual report.

The Town of Foxborough will implement the following catch basin inspection and cleaning procedures to reduce the discharge of pollutants from the MS4:

## Procedures

### Inspection and Cleaning Frequency

- Each catch basin should be cleaned and inspected at least annually.
- Catch basins near construction activities (roadway construction, residential, commercial, or industrial development or redevelopment) or high-use areas should be inspected and cleaned more frequently if inspection finds excessive sediments or debris loadings.
- Catch basins should be cleaned to ensure that they are no more than 50 percent full<sup>1</sup> at any time. Establish inspection and maintenance frequencies needed to meet this "50 percent" goal. If a catch basin sump is more than 50 percent full during two consecutive inspections, document the findings, investigate the contributing drainage area for sources of excessive sediment loading, and, if possible, address the contributing sources. If no contributing sources are found, increase the inspection and cleaning frequencies of the sump.
- Street sweeping performed on an appropriate schedule will reduce the amount of sediment, debris, and organic matter entering the catch basins, which will in turn reduce the frequency with which they need to be cleaned. Reference SOP 16: Streets and Parking Lots for information on appropriate street sweeping frequencies. Street sweeping schedules should also be adjusted based on catch basin inspection findings, with more frequent sweepings for areas with higher catch basin loads.

---

<sup>1</sup> A catch basin sump is more than 50 percent full if the contents within the sump exceed one half the distance between the bottom interior of the catch basin to the invert of the deepest outlet of the catch basin



### Inspection and Cleaning Procedures

Catch basin inspection and cleaning procedures should address both the grate opening and the catch basin structure, including the sump and any inlet and outlet pipes. Document any and all observations about the condition of the catch basin structure and water quality (an inspection form and log of catch basins cleaned or inspected are included in the attachments). Collect data on the condition of the physical basin structure, its frame, and the grate, as well as on the quality of stormwater conveyed by the structure. Observations like those below can indicate sources of pollution within the storm drain system:

- Oil sheen
- Discoloration
- Trash and debris

Both oil and bacteria can create a sheen on the water's surface. The source of a sheen can be differentiating by disturbing it (e.g., with a pole). A sheen caused by oil will remain intact and move in a swirl pattern, while a sheen caused by bacteria will separate and appear "blocky." The bacteria that cause this sheen are naturally occurring iron bacteria – they are not considered a pollutant but should be noted. Other types of bacteria, such as fecal bacteria, are considered pollutants and their discovery should be recorded.

Observations like those below can indicate a potential connection of a sanitary sewer to the storm drain system, which is an illicit discharge:

- Indications of sanitary sewage, including fecal matter or sewage odors
- Foaming, such as from detergent
- Optical enhancers, fluorescent dye added to laundry detergent

In general, adhere to the following procedures when inspecting and cleaning catch basins. Record the findings in the log in the attachments:

1. Implement appropriate traffic safety procedures (e.g., traffic cones) prior to and during the catch basin inspection and cleaning process.
2. Work upstream to downstream in a given drainage network.
3. Clean sediment and trash off of the grate.
4. Visually inspect the outside of the grate.
5. Remove the grate and visually inspect the inside of the catch basin to determine cleaning needs.
6. Inspect the catch basin for structural integrity.
7. Determine the most appropriate equipment and method for cleaning the basin:
  - a. Manually use a shovel to remove accumulated sediments.
  - b. Use a bucket loader to remove accumulated sediments.
  - c. Use a high pressure washer to clean any remaining material out of the catch basin while capturing the slurry with a vacuum.
  - d. If necessary, after the catch basin is cleaned, use the rodder of the vacuum truck to clean the downstream pipe and pull back sediment that might have entered it.
8. If contamination is suspected, chemical analysis will be required to determine if the materials comply with the Massachusetts Department of Environmental Protection (MassDEP) Hazardous Waste Regulations, 310 CMR 30.000 ([https://www.mass.gov/files/documents/2016/08/xl/310cmr30\\_7883\\_54357.pdf](https://www.mass.gov/files/documents/2016/08/xl/310cmr30_7883_54357.pdf)). The chemical

analysis required will depend on suspected contaminants. Note the identification number of the catch basin on the sample label and note sample collection on the Catch Basin Inspection Form.

### **Handling and Disposal of Catch Basin Cleanings**

- Properly dispose of collected sediments and catch basin cleanings (solid material, such as leaves, sand, and twigs removed from stormwater collection systems during cleaning operations).
- Cleanings from stormwater-only drainage systems may be disposed at any landfill that is permitted by MassDEP to accept solid waste. MassDEP does not routinely require stormwater-only catch basin cleanings to be tested before disposal, unless there is evidence that they have been contaminated by a spill or some other means.
- Screenings may need to be placed in a drying bed to allow water to evaporate before proper disposal. In this case, ensure that the screenings are managed properly to prevent pollution.
- Catch basin cleanings must be handled and disposed in accordance with compliance with the applicable MassDEP regulations, policies, and guidance (<https://www.mass.gov/files/documents/2018/03/09/catch-basins.pdf>).

### **Documentation and Reporting**

The following information should be documented and included in the municipality's annual report – use the catch basin inspection log provided in the attachments to document the information to include in the report (alternatively, obtain records of volume of debris removed to include in the report):

- Metrics and other information used to reach the determination that the established plan for cleaning and maintenance is optimal for the MS4 (include in the SWMP and first annual report)
- Any action taken in response to excessive sediment or debris loadings
- Total number of catch basins
- Number of catch basins inspected
- Number of catch basins cleaned
- Total volume or mass of material removed from catch basins.

### **Employee Training**

- Employees who perform catch basin cleaning and inspection are trained once per year on these procedures and the proper operation of related equipment.
- Employees are also trained on stormwater pollution prevention, illicit discharge detection and elimination (IDDE) procedures, and spill and response procedures.
- If services are contracted, the contractor should be given a copy of this and any applicable SOPs to ensure compliance with MS4 regulations.

### **Attachments**

1. Catch Basin Inspection Form and Log
2. Catch Basin Inventory

### **Related Standard Operating Procedures**

1. SOP 16: Streets and Parking Lots

**CATCH BASIN INSPECTION FORM**

**Job No.:** \_\_\_\_\_ **Town:** \_\_\_\_\_ **Inspector:** \_\_\_\_\_ **Date:** \_\_\_\_\_

<b>Catch Basin I.D.</b>		<b>Final Discharge from Structure?</b> Yes <input type="checkbox"/> No <input type="checkbox"/> <b>If Yes, Discharge to Outfall No:</b> _____		
<b>Catch Basin Label:</b>	Stencil <input type="checkbox"/>	Ground Inset <input type="checkbox"/>	Sign <input type="checkbox"/>	None <input type="checkbox"/> Other _____
<b>Basin Material:</b>	Concrete <input type="checkbox"/> Corrugated metal <input type="checkbox"/> Stone <input type="checkbox"/> Brick <input type="checkbox"/> Other: _____ <input type="checkbox"/>	<b>Catch Basin Condition:</b>		Good <input type="checkbox"/> Poor <input type="checkbox"/> Fair <input type="checkbox"/> Crumbling <input type="checkbox"/>
<b>Pipe Material:</b>	Concrete <input type="checkbox"/> HDPE <input type="checkbox"/> PVC <input type="checkbox"/> Clay Tile <input type="checkbox"/> Other: _____ <input type="checkbox"/>	<b>Pipe Measurements:</b>		Inlet Dia. (in): d= _____ Outlet Dia. (in): D= _____
<b>Required Maintenance/ Problems (check all that apply):</b>				
<input type="checkbox"/> Tree Work Required <input type="checkbox"/> New Grate is Required <input type="checkbox"/> Pipe is Blocked <input type="checkbox"/> Frame Maintenance is Required <input type="checkbox"/> Remove Accumulated Sediment <input type="checkbox"/> Pipe Maintenance is Required <input type="checkbox"/> Basin Undermined or Bypassed		<input type="checkbox"/> Cannot Remove Cover <input type="checkbox"/> Ditch Work <input type="checkbox"/> Corrosion at Structure <input type="checkbox"/> Erosion Around Structure <input type="checkbox"/> Remove Trash & Debris <input type="checkbox"/> Need Cement Around Grate <b>Other:</b> _____		
<b>Catch Basin Grate Type:</b>	<b>Sediment Buildup Depth:</b>	<b>More than 50% full?</b>	<b>Description of Flow:</b>	<b>Street Name/ Structure Location:</b>
Bar: <input type="checkbox"/> Cascade: <input type="checkbox"/> Other: _____  Properly Aligned: Yes <input type="checkbox"/> No <input type="checkbox"/>	0-6 (in): _____ 6-12(in): _____ 12-18 (in): _____ 18-24 (in): _____ 24 + (in): _____	Yes <input type="checkbox"/>  No <input type="checkbox"/>	Heavy <input type="checkbox"/> Moderate <input type="checkbox"/> Slight <input type="checkbox"/> Trickling <input type="checkbox"/>	
<b>*If the outlet is submerged check yes and indicate approximate height of water above the outlet invert. h above invert (in):_</b>			Yes <input type="checkbox"/>	No <input type="checkbox"/>
<input type="checkbox"/> Flow <input type="checkbox"/> Standing Water (check one or both)	<b>Observations:</b>		<b>Circle those present:</b>	
	Color: _____		Foam	Oil Sheen
	Odor: _____		Sanitary Waste	Bacterial Sheen
<b>Weather Conditions :</b>	Dry > 24 hours <input type="checkbox"/>	Wet <input type="checkbox"/>	Orange Staining	Floatables
<b>Sample of Screenings Collected for Analysis?</b> Yes <input type="checkbox"/> No <input type="checkbox"/>			Excessive sediment	Pet Waste
<b>Amount of sediment removed:</b>			Other: _____	Optical Enhancers
<b>Comments:</b>				



## Department of Environmental Protection

One Winter Street Boston, MA 02108 • 617-292-5500

### Management of Catch Basin Cleanings

Catch basin cleanings - solid materials such as leaves, sand and twigs removed from storm water collection systems during cleaning operations - are typically classified as a solid waste by the Department of Environmental Protection (MassDEP). Catch basin cleanings must be handled and disposed in accordance with the agency's applicable regulations, policies and guidance.

#### Handling & Disposal

Except as explained below, catch basin cleanings from storm water-only drainage systems may be disposed at any landfill that is permitted by MassDEP to accept solid waste.

MassDEP does not routinely require storm water only catch basin cleanings to be tested before disposal, unless there is evidence that they have been contaminated by a spill or some other means. Contaminated catch basin cleanings must be evaluated in accordance with [310 CR 30.000: Hazardous Waste Regulations](#) and handled as hazardous waste if appropriate.

Systems that collect storm water run-off into sanitary sewers are called "combined sewers." MassDEP may require cleanings from combined sewer catch basins to be tested before disposal.

#### Landfill Restrictions

The MassDEP [310 CMR 19.000: Solid Waste Management Facility Regulations](#) (specifically see Section 19.130(7)) prohibit Massachusetts landfills from accepting materials that contain free draining liquids. When there is no free water in a truck used to transport catch basin cleanings, the agency will generally be satisfied that the material is sufficiently dry. Otherwise, the material will need to undergo a Paint Filter Liquids Test.

One way to remove liquids is to use a hydraulic lift truck during catch basin cleaning operations so that the material can be decanted at the site. After material from several catch basins along the same system is loaded, the truck may be elevated so that any free draining liquid is allowed to flow back into the drainage structure.

MassDEP may approve catch basin cleanings for use as grading and shaping material at landfills undergoing closure (see the agency's Revised Guidelines for Determining Closure Activities at Inactive Unlined Landfill Sites for additional information). Catch basin cleanings may be used as daily cover or grading material at active landfills only with specific MassDEP approval of the proposed use.

Consult with the Solid Waste Section Chief in the appropriate MassDEP Regional Office for information about applying for an approval and/or a Beneficial Use Determination (see Section 19.060 for other uses, including non-landfill uses).



# SOP 4: Spill Response and Cleanup

## Introduction

Municipalities are responsible for any contaminant spill or release that occurs on property that they own or operate. Particular areas of concern include any facilities that use or store chemicals, fuel oil, or hazardous waste, including schools, garages, and landfills. Implementation of proper spill response and cleanup procedures can help to mitigate the effects of a contaminant release. The goal of this written Standard Operating Procedure (SOP) is to provide guidance to municipal employees to help reduce the discharge of pollutants from the MS4 as a result of spills or releases.

The Town of Foxborough undertakes various precautions with spill response and cleanup procedures. Containment materials and secondary storage must be available where every hazardous materials are stored. Above ground storage exceeding 1,320 gallons has triggered the requirement to develop a Spill Prevention, Control and Countermeasure (SPCC) plan and should be completed within Year 3 of the MS4 permit.

## Procedures

The Town of Foxborough will implement the following spill response and cleanup procedures to reduce the discharge of pollutants from the MS4:

### Responding to a Spill

Employees should be trained in proper spill response specific to the materials used at their site and appropriate personal protective equipment (PPE). In the event of a spill, follow these spill response and cleanup procedures:

- If the facility has a Stormwater Pollution Prevention Plan (SWPPP), notify a member of the facility's Pollution Prevention Team, the facility supervisor, and/or the facility safety officer (fill out the attached spill response contact list). If not, continue to follow the procedures outlined below.
- Assess the contaminant release site for potential safety issues and for direction of flow.
- Complete the following:
  - Stop the contaminant release.
  - Contain the contaminant release through the use of spill containment berms or absorbents.
  - Protect all drains and/or catch basins with the use of absorbents, booms, berms or drain covers.
  - Clean up the spill.
  - Dispose of all contaminated products in accordance with applicable federal, state and local regulations.
    - i. Soil contaminated with petroleum should be handled and disposed of as described in MassDEP policy WCS-94-400, Interim Remediation Waste Management Policy for Petroleum Contaminated Soils (<https://www.mass.gov/files/documents/2016/08/mq/94-400.pdf>).
    - ii. Products saturated with petroleum products or other hazardous chemicals require special handling and disposal by licensed transporters. Licensed transporters will pick up spill contaminated materials for recycling or disposal. Save the shipping records for at least three years.

- iii. Waste oil contaminated industrial wipes and sorptive minerals:
  1. Perform the “one drop” test to ensure absorbents do not contain enough oil to be considered hazardous, as described in the MassDEP Waste Oil Management Guide  
<https://www.mass.gov/files/documents/2018/12/18/oilwiper.pdf>.
  2. Wring absorbents through a paint filter. If doing so does not generate one drop of oil, the materials are not hazardous.
  3. If absorbents pass the “one drop” test they may be discarded in the trash unless contaminated with another hazardous waste.
    - a. It is acceptable to mix the following fluids and handle them as waste oil:
      - i. Waste motor oil
      - ii. Hydraulic fluid
      - iii. Power steering fluid
      - iv. Transmission fluid
      - v. Brake fluid
      - vi. Gear oil
    - b. **Do not mix** the following materials with waste oil. Store each separately:
      - i. Gasoline
      - ii. Antifreeze
      - iii. Brake and carburetor cleaners
      - iv. Cleaning solvents
      - v. Other hazardous wastes
  4. If absorbents do not pass the “one drop” test they should be placed in separate metal containers with tight fitting lids, labeled “Oily Waste Absorbents Only.”
- If you need assistance containing and/or cleaning up the spill, or preventing it from discharging to a surface water (or an engineered storm drain system), contact your local fire department using the number listed below. **In the case of an emergency call 911.**
  - FOXBORO FIRE DEPARTMENT: 508-543-1230
- Contact the MassDEP 24-hour spill reporting notification line, toll-free at **(888)-304-1133**;
  - The following scenarios **are exempt** from MassDEP reporting requirements (see the MassDEP factsheet on oil and hazardous materials handling for more information:  
<https://www.mass.gov/files/documents/2016/08/xm/spillmgm.pdf>).
    - i. Spills that are less than 10 gallons of petroleum and do not impact a water body
    - ii. Spills that are less than one pound of hazardous chemicals and do not present an imminent health or safety hazard
    - iii. Fuel spills from passenger vehicle accidents
    - iv. Spills within a vault or building with a watertight floor and walls that completely contain all released chemicals

### Reporting a Spill

When contacting emergency response personnel or a regulatory agency, or when reporting the contaminant release, be prepared to provide the following information:

1. Your name and the phone number you are calling from.
2. The exact address and location of the contaminant release.
3. Specifics of release, including:
  - a. What was released;
  - b. How much was released, which may include:
    - i. Pounds
    - ii. Gallons
    - iii. Number of containers
4. Where was the release sent/what was contaminated, addressing:
  - a. Pavement
  - b. Soil
  - c. Drains
  - d. Catch basins
  - e. Water bodies
  - f. Public streets
  - g. Public sidewalks
5. The concentration of the released contaminant.
6. What/who caused the release.
7. Is the release being contained and/or cleaned up or is the response complete.
8. Type and amount of petroleum stored on site, if any.
9. Characteristics of contaminant container, including:
  - a. Tanks
  - b. Pipes
  - c. Valves

### **Maintenance and Prevention Guidance**

Prevention of spills is preferable to even the best response and cleanup. To mitigate the effects of a contaminant release, provide proper maintenance and inspection at each facility. To protect against contaminant release adhere to the following guidance:

- Ensure all employees are properly trained to respond in the case of a spill, understand the nature and properties of the contaminant, and understand the spill control materials and personnel safety equipment. Maintain training records of current personnel on site and retain training records of former personnel for at least three years from the date last worked at the facility.
- Provide yearly maintenance and inspection at all municipal facilities, paying particular attention to underground storage tanks. Maintain maintenance and inspection records on site.
- Implement good management practices where chemicals and hazardous wastes are stored:
  - a. Ensure storage in closed containers inside a building and on an impervious surface wherever possible.
  - b. If storage cannot be provided inside, ensure secondary containment for 110 percent of the maximum volume of the storage container.
  - c. Locate storage areas near maintenance areas to decrease the distance required for transfer.
  - d. Provide accurate labels, Material Safety Data Sheets (MSDS) information, and warnings for all stored materials.
  - e. Regularly inspect storage areas for leaks.
  - f. Ensure secure storage locations, preventing access by untrained or unauthorized persons.



- g. Maintain accurate records of stored materials.
- Replace traditional hazardous materials such as pesticides and cleansers with non-hazardous products such as bio-lubricants which can reduce response costs in the case of a spill.

Maintain appropriately stocked spill response kits at each facilities and locations where oil, chemicals, or other hazardous materials are handled and stored.

### **Employee Training**

- Employees who perform work with potential stormwater pollutants once per year on proper spill procedures.
- Employees are also trained on stormwater pollution prevention and illicit discharge detection and elimination (IDDE) procedures.
- If services are contracted, the contractor should be given a copy of this and any applicable SOPs to ensure compliance with MS4 regulations.

### **Attachments**

1. Spill Response and Cleanup Contact List

**Spill Response and Cleanup Contact List**

Contact	Phone Number	Date and Time Contacted
Safety Officer: _____		
Facility Supervisor: _____		
Fire Department: _____	<b>(508) 543-1230</b>	
MassDEP 24-Hour Spill Reporting	<b>(888) 304-1133</b>	
MassDEP Regional Offices:		
Northeast Regional Office	<b>(978) 694-3200</b>	
Southeast Regional Office	<b>(508) 946-2700</b>	
Central Regional Office	<b>(508) 792-7650</b>	
Western Regional Office	<b>(413) 784-1100</b>	
Hazardous Waste Compliance Assistance Line	<b>(617) 292-5898</b>	
Household Hazardous Products Hotline	<b>(800) 343-3420</b>	
Massachusetts Department of Fire Services	<b>(978) 567-3100 or (413) 587-3181</b>	
Licensed Site Professionals Association (Wakefield, MA)	<b>(781) 876-8915 (617) 556-1091</b>	
Licensed Site Professionals Board		



Massachusetts  
Department  
of  
ENVIRONMENTAL  
PROTECTION

# fact sheet

## Managing spills of oil and hazardous materials

### Information for municipalities

#### Purpose

Oil or chemical spill responses are local events. Because timely action is critical to the success of any cleanup, the Massachusetts Department of Environmental Protection (MassDEP) has prepared this guide to help municipal officials:

- Take defensive action at all spills to identify receptors and limit/contain the release
- After relevant training, take proactive actions to control and clean up spills of limited scope
- Provide support, in accordance with the Incident Management System, to the Fire Department, which normally is the lead agency in spill response situations
- Determine when MassDEP or a Licensed Site Professional (LSP) needs to lead a cleanup
- Represent the municipality's interests in cleanup decisions

#### Who must clean up a spill?

The primary responsibility for hiring contractors for on-site cleanup and disposal of waste materials, including all associated costs, rests with the person or party that causes or contributes to the release and/or with the owner of the property where it happens. They are collectively referred to as Potentially Responsible Parties (PRPs).<sup>1</sup>



*Methuen Fire Department response to liquid asphalt spill. Photo by Steven Ross, MassDEP.*

<sup>1</sup> M.G.L. Chapter 21E (the Massachusetts Oil and Hazardous Material Release Prevention Act) and 310 CMR 40.0000 (the Massachusetts Contingency Plan, or MCP) spell out the procedures and requirements for release notification, spill response and the cleanup standards that must be met.

Massachusetts Department of  
Environmental Protection  
One Winter Street  
Boston, MA 02108-4746

Commonwealth of Massachusetts  
Mitt Romney, Governor  
Kerry Healey, Lt. Governor

Executive Office of  
Environmental Affairs  
Stephen R. Pritchard, Secretary

Department of  
Environmental Protection  
Robert W. Gollodge, Jr.,  
Commissioner

Produced by the  
Bureau of Waste Site Cleanup,  
2/01, rev. 4/04, 4/06  
Printed on recycled paper

This information is available in  
alternate format by calling our ADA  
Coordinator at  
(617) 56-1057.



## Does the size, type, or location of a spill make a difference?

Yes. Depending on the size and type of spill, MassDEP and other local, state, and federal agencies may have a role in spill response. The PRP must report spills to MassDEP if they exceed specific thresholds. Some releases are exempt from reporting requirements under the MCP. These are spills that involve:

- less than 10 gallons of petroleum and which does not impact a waterbody
- less than one pound of hazardous chemicals and which does not pose an imminent hazard
- fuel from passenger vehicle accidents or
- a vault or building with a watertight floor and with walls that completely contain all released chemicals

Regardless of whether MassDEP notification is required, all spills of oil and hazardous materials must be cleaned up to the extent that no risk to human health is present.

## Who responds to oil and hazardous material releases of a limited scope?

The fire department normally responds to spills, initiates containment, and usually directs cleanup of spills of limited scope, i.e. those that do not trigger MassDEP reporting thresholds. When the PRP is unable or unwilling to take responsibility, the fire department may also arrange for cleanup, either by hiring an outside contractor or by using in-house resources. The municipal public works department or other local agencies sometimes provide support. MassDEP generally does not respond to non-reportable releases or those of limited scope, but will be available for technical support. MassDEP will always respond to larger and more complicated spills with potential for posing imminent health, safety, or environmental hazards. MassDEP also attempts to respond to releases where public safety officials request assistance in directing the cleanup.

## What specific roles do local officials play?

First responders to a spill are usually equipped to take some action to contain it. Containment is critical to protecting resources at risk. For example, the fire department might take measures to stop the flow or contain the release with absorbents, while public works personnel deliver and spread sand, pick up debris, and provide street drainage maps to aid in the spill investigation. Some municipalities have one or more environmental cleanup firms on retainer to help deal with responses to spills of limited scope.

When PRPs are unable or unwilling to respond, a statewide comprehensive "Hazardous Materials and Medical Waste Collection and Disposal" (FAC36) contract can be used by towns, cities, and state agencies to hire cleanup companies. The contract also provides for emergency response preparedness training for government workers. The contract establishes "Not to Exceed" rates for labor, transportation, and oil and hazardous materials disposal. Information about the Comm-PASS contract may be found at the web site of the Massachusetts Operational Services Division at [www.mass.gov/osd](http://www.mass.gov/osd).

## What training is necessary for cleanup workers?

Because of their roles as first responders and the associated risks of direct exposure to hazardous chemicals, fire department personnel typically undergo training to deal with petroleum and chemical releases, as described in OSHA 1910.120. The International Association of Fire Fighters and the Massachusetts Firefighting Academy offer training programs.

Basic awareness training is highly recommended for staff from other municipal agencies who may be at less risk of direct exposure but still play critical support roles.

## How do wastes from spill cleanups need to be handled?

Sand and absorbents contaminated with petroleum can be reused, disposed, or otherwise handled as described in MassDEP policy WSC-94-400, Interim Remediation Waste Management Policy for Petroleum Contaminated Soils, [www.mass.gov/dep/images/wsc94400.pdf](http://www.mass.gov/dep/images/wsc94400.pdf). But sand and absorbents that are saturated

with petroleum products or by other hazardous chemicals may need special handling (disposal) by licensed transporters. Depending on the size and severity of a spill, a Licensed Site Professional (LSP) may also need to be hired to oversee the cleanup and sign-off on the disposal. MassDEP requires municipalities to properly manage and store small quantities of hazardous materials from spill cleanups. If storage that is consistent with MassDEP guidelines is not possible, an environmental waste removal firm should be hired to remove the material.

#### Contacting MassDEP Regional Offices:

Northeast Regional Office – 205B Lowell Street, Wilmington, Massachusetts 01887

<http://www.mass.gov/dep/about/region/northeast.htm> (978) 694-3200

Southeast Regional Office - 20 Riverside Dr., Lakeville, MA 02347

<http://www.mass.gov/dep/about/region/southeast.htm> (508) 946-2700

Central Regional Office - 627 Main St., Worcester, MA 01608

<http://www.mass.gov/dep/about/region/centralr.htm> (508) 792-7650

Western Regional Office - 436 Dwight St., Springfield, MA 01103

<http://www.mass.gov/dep/about/region/westernr.htm> (413) 784-1100

Visit <http://www.mass.gov/dep/about/region/findyour.htm> to determine which MassDEP regional office serves your community.

#### For more information:

- If you have questions, please email MassDEP at [BWSC.Information@state.ma.us](mailto:BWSC.Information@state.ma.us).
- For copies of MassDEP regulations, policies, and other publications, visit: <http://www.mass.gov/dep/bwsc/pubs.htm>

#### Related regulations and guidance documents:

- Interim Remediation Waste Management Policy for Petroleum Contaminated Soil, WSC-94-400, [www.mass.gov/dep/images/wsc94400.pdf](http://www.mass.gov/dep/images/wsc94400.pdf)
- Reuse and Disposal of Contaminated Soil at Massachusetts Landfills, COMM-97-001, <http://www.mass.gov/dep/recycle/laws/97-001.htm>
- Characteristics of Hazardous Waste, 310 CMR 30.120, <http://www.mass.gov/dep/service/regulations/310cmr30.pdf>
- A Summary of Requirements for Small Quantity Generators, <http://www.mass.gov/dep/recycle/laws/sqgsum.pdf>

#### MassDEP Telephone numbers:

- Hazardous Waste Compliance Assistance Line – (617) 292-5898
- Household Hazardous Products Hotline – (800) 343-3420

#### Above ground or underground storage tanks:

Call the local fire department or the Massachusetts Department of Fire Services at (978) 567-3100 or 413-587-3181.

#### LSP information:

Visit the LSP Board's web page at <http://www.mass.gov/lsp> or call (617) 556-1091.

---

## MassDEP 24-hour Spill Reporting

### To report a release of oil or hazardous materials, and other environmental emergencies, call the MassDEP 24-hour notification line toll-free at

# (888) 304-1133

Massachusetts Department of  
Environmental Protection  
One Winter Street  
Boston, MA 02108-4746

Commonwealth of Massachusetts  
Mitt Romney, Governor  
Kerry Healey, Lt. Governor

Executive Office of  
Environmental Affairs  
Stephen R. Pritchard, Secretary

Department of  
Environmental Protection  
Robert W. Gollodge, Jr.,  
Commissioner

Produced by the  
Bureau of Waste Site Cleanup,  
2/01, rev. 4/04, 4/06  
Printed on recycled paper

This information is available in  
alternate format by calling our ADA  
Coordinator at  
(617) 56-1057.





Massachusetts  
Department  
of  
ENVIRONMENTAL  
PROTECTION

# WASTE MANAGEMENT GUIDANCE FOR INDUSTRIAL WIPERS AND SORPTIVE MINERALS CONTAMINATED WITH WASTE OIL

**Policy BWP 92-02**, signed by Steven A. DeGabriele, Acting Director, Division of Hazardous Waste, May 20, 1992. Reference to Policy #WSC-400-89 was changed on April, 2001 to Policy #WSC 94-400 which supersedes the previous Policy.

## Summary

The Department of Environmental Protection (DEP) provides the following guidance on the applicability of the mixture rule, MGL Chapter 21C, 310 CMR 30.140 (1) (c), to sorptive minerals and industrial wipers that do not contain free-flowing waste oil<sup>1</sup> and are therefore non-saturated. "Sorptive minerals" refers to absorbent clays or diatomaceous earth materials used in commercial and industrial settings, such as auto repair and machine shops. "Industrial wipers" refers to shop towels, rags and disposable wipers used in similar situations.

It is DEP's position that oily, non-saturated, industrial wipers and sorptive minerals do not typically pose a significant threat to human health when managed properly and that this policy provides a sufficient degree of environmental protection. DEP's policy is consistent with EPA's recent proposed rule to regulate waste oil, which included a conditional exemption to the mixture rule for industrial wipers and sorptive minerals.

## Conditional Exemptions to the Mixture Rule

The Department interprets the mixture rule as inapplicable to sorptive minerals and industrial wipers that are contaminated with only small amounts of waste oil, provided that:

- They do not contain free-flowing waste oil, as defined by "one drop" in this guidance document, and
- They are used ONLY for spills or leaks when collection of waste oil as liquid is not feasible or practical.

This interpretation does not allow generators to dilute hazardous waste with solid waste so the mixture can be deemed non-hazardous. Intentional dilution of waste oil that could otherwise have been collected as a liquid is a violation of MGL Chapter 21C and 310 CMR 30.000. To the greatest extent possible, waste oils shall be collected in their liquid state for subsequent reuse, recycling, treatment or disposal in accordance with MGL Chapter 21C and 310 CMR 30.000, and any other applicable environmental protection requirements.

---

<sup>1</sup> "Waste Oil" as defined in 310 CMR 30.131. Additionally, "waste oil" refers to both "used waste oil" and "unused waste oil", as defined in 310 CMR 30.010.

Further, this interpretation covers only waste oil-contaminated sorptive minerals and industrial wipers, and does not apply to other hazardous wastes, such as listed solvents. For virgin (“unused”) oil-contaminated absorbent materials used at sites subject to Chapter 21E (releases to soil or ground or surface water), generators should refer to Section 4.0 of DEP Policy #WSC-94-400, “Interim Remediation Waste Management Policy for Petroleum Contaminated Soils.”

## **The “One Drop” Rule/Testing Procedures**

DEP will use the “one drop” approach in EPA’s proposed rule on waste oil (Federal Register, September 23, 1991, vol. 56, p. 48025) as the means for determining whether sorptive minerals and industrial wipers contaminated with waste oil are saturated and therefore hazardous. As long as one drop of oil can flow from a mixture when subjected to its respective test, the mixture is saturated and, therefore, hazardous. The one drop approach employs a simple and inexpensive testing procedure.

The Paint Filter Liquids Test (310 CMR 30.156) shall be the method for determining whether oil/sorptive mineral mixtures pass the one drop test. For industrial wipers, the one drop determination shall be made by “wringing” the rags out by hand or by some other mechanical compaction method. If it is apparent that the industrial wipers or sorptive minerals are non-saturated, testing may not be necessary, though generators remain responsible for proving that their waste can pass the one drop test.

## **Preferred Material Management Practices**

### **Sorptive materials that fail the one drop test:**

The standard rules of hazardous waste management shall pertain to 1) industrial wipers that contain free-flowing waste oil; 2) used, sorptive minerals containing free-flowing waste oil; and 3) all free-flowing waste oil removed from sorptive minerals and industrial wipers.

Proper management of these materials requires compliance with applicable provisions of 310 CMR 30.000, including segregating each type of waste; keeping containers closed, except to add or remove waste; and labeling each container with “Waste Oil” and “Toxic” and the date accumulation began in that container. Waste oil-saturated materials must be transported and disposed in accordance with 310 CMR 30.000.

### **Materials that pass the one drop test:**

Waste oil/sorptive mineral mixtures and industrial wipers that pass the one drop test, and which are used only when it is not feasible or practical to collect the waste oil as a liquid, are not hazardous waste, and therefore have several waste management options as a solid waste. DEP recommends that generators follow the Bureau of Waste Prevention’s hierarchy of solid waste management, which is to first reduce; second, to reuse/recycle; third, to incinerate in a waste-to-energy facility; and last, to landfill.

As an example, the order of DEP’s recommendations is

first, conservative use of absorbent materials,

second, recycling by laundering rags or substituting reusable drip mats for sorptive minerals, or reuse of sorptive minerals at an asphalt batching facility;

third, energy recovery at an incinerator; and finally, disposal at a lined landfill with leachate control.

## EPA's Position and Supporting Data

DEP's interpretation is consistent with EPA's September 23, 1991 proposed rule to regulate waste oil as hazardous waste, which includes a discussion on the "Applicability of the [Federal] Mixture Rule to Specific Solid Wastes" and conditional exemptions for industrial wipers and sorptive minerals.

EPA's position is based in part on comments it received in 1986 on a proposal to amend the mixture rule to exclude sorptive minerals. Analytical data provided by the Sorptive Minerals Institute (SMI) showed that waste oil/sorptive mineral mixtures did not release hazardous constituents under pressure and that significant quantities of hazardous constituents did not leach out of sorptive minerals. Further SMI testing using the TCLP showed that the constituents of concern did not leach when exposed to prolonged TCLP extraction. EPA concluded, based on this data, that these mixtures were unlikely to pose a hazard when disposed, and that an exemption from the mixture rule should be considered.

EPA's view is also based on comments it received on its 1985 proposal to regulate waste oil as a hazardous waste and to allow a conditional exemption to the mixture rule for industrial wipers. EPA stated in its proposed waste oil rule last September that a wiper not containing free-flowing waste oil would be considered non-hazardous waste since it would contain "insignificant quantities" of waste oil.

Further, the EPA is currently reviewing a regulatory petition requesting a conditional exemption from hazardous waste status, under the mixture rule, for wipers contaminated with listed solvents. While a determination is pending on this interpretation, the EPA has directed its regions and states to use a case-by-case approach in formulating policy on this subject.

DEP will continue to evaluate the need for rulemaking and regulatory guidance in this area. Specifically, DEP's interpretation of 310 CMR 30.140(1) (c) may be subject to revision as the EPA is currently reevaluating its mixture rule and considering other ways to regulate waste mixtures.

Questions should be addressed to James Paterson at telephone number (617) 556-1096.

Massachusetts Department of  
Environmental Protection  
One Winter Street  
Boston, MA 02108-4746

Commonwealth of  
Massachusetts  
Argeo Paul Cellucci, Governor  
Jane Swift, Lt. Governor

Executive Office of  
Environmental Affairs  
Bob Durand, Secretary

Department of  
Environmental Protection  
Lauren A. Liss, Commissioner

Produced by the  
Bureau of Waste Prevention  
Business Compliance Division  
March 2001. Printed on recycled  
paper.

This information is available in  
alternate format by calling our  
ADA Coordinator at  
(617) 574-6872.





## SOP 5: CONSTRUCTION SITE INSPECTION

Construction sites that lack adequate stormwater controls can contribute a significant amount of sediment to nearby bodies of water. This Standard Operating Procedure describes the major components of a municipal Stormwater Construction Inspection Plan, as well as procedures for evaluating compliance of stormwater controls at construction sites.

### *Stormwater Construction Inspection Plan*

A stormwater Construction Site Inspection program is a program developed by municipalities to track, inspect, and enforce local stormwater requirements at construction sites.

This SOP assumes that the municipality has legal authority (i.e., a bylaw or ordinance) in place, per the requirements of the 2003 Massachusetts MS4 Permit, to require sediment and erosion control at construction sites. This legal authority must require construction site operators “to implement a sediment and erosion control program which includes [Best Management Practices] that are appropriate for the conditions at the construction site, including efforts to minimize the area of the land disturbance.” The legal authority must also give inspectors the authority to enter the site.

A municipal stormwater Construction Site Inspection program should include or address the following:

1. Construction Site Inventory
  - A tracking system to inventory projects and identify sites for inspection.
  - Track the results of inspection and prioritize sites based on factors such as proximity to waterways, size, slope, and history of past violations.
2. Construction Requirements and BMPs
  - Municipalities provide contractors with guidance on the appropriate selection and design of stormwater BMPs.
3. Plan Review Procedures
  - Submitted plans must be reviewed to ensure they address local requirements and protect water quality.
4. Public Input
  - Per the 2003 Massachusetts MS4 Permit, a program must allow the public to provide comment on inspection procedures, and must consider information provided by the public.
5. Construction Site Inspections
  - Identify an inspection frequency for each site.
  - See more detailed information below.
6. Enforcement Procedures
  - A written progressive enforcement policy for the inspection program.

- Sanctions, both monetary and non-monetary, shall be utilized to ensure compliance with the program
7. Training and Education
- Municipal staff conducting inspections should receive training on regulatory requirements, BMPs, inspections, and enforcement.

### *Conducting Stormwater Inspections at Construction Sites*

The role of the construction inspector is to ensure that site operations match the approved site plans and the Stormwater Pollution Prevention Plan (SWPPP) for the project, and that all precautions are taken to prevent pollutants and sediment from the construction site from impacting local waterways. The inspector is also expected to determine the adequacy of construction site stormwater quality control measures.

The attached Construction Site Stormwater Inspection Report shall be used by the inspector during site visits. Construction site inspectors should abide by the following guidelines:

1. Inspections to monitor stormwater compliance should be performed at least once per month at each active construction site, with priority placed on sites that require coverage under the USEPA 2012 Construction General Permit (i.e., that disturb one or more acres), and sites that are located in the watershed of any 303(d) water bodies.
2. The inspection shall begin at a low point and work uphill, observing all discharge points and any off-site support activities.
3. Written and photographic records shall be maintained for each site visit.
4. During the inspection, the inspector should ask questions of the contractor. Understanding the selection, implementation, and maintenance of BMPs is an important goal of the inspection process, and requires site-specific input.
5. The inspector should not recommend or endorse solutions or products. The inspector may offer appropriate advice, but all decisions must be made by the contractor.
6. The inspector shall always wear personal protective equipment appropriate for the site.
7. The inspector shall abide by the contractor's site-specific safety requirements.
8. The inspector has legal authority to enter the site. However, if denied permission to enter the site, the inspector should never force entry.

Prior to planning a site visit, the inspector shall determine if the project is subject to USEPA's 2012 Construction General Permit, which is true if the the project disturbs one or more acres, total. The 2012 Construction General Permit replaces the 2008 Construction General Permit , which expired on February 15, 2012. Operators of sites that required coverage under the USEPA's 2008 Construction General Permit but continue to be active should have submitted a new Notice of Intent (NOI) under the 2012 Permit.

If the site requires this coverage, the inspector shall visit the USEPA Region 1 eNOI website (<http://cfpub.epa.gov/npdes/stormwater/cgpenoi.cfm> or [http://cfpub.epa.gov/npdes/stormwater/ noi/noisearch.cfm](http://cfpub.epa.gov/npdes/stormwater/noi/noisearch.cfm)) to determine if the contractor filed for coverage under the 2012 and/or 2008 Construction General Permits, respectively. Print a copy of the project's NOI.

If the project disturbs one or more acres and is under construction, but does not show up in either database, the project is in violation of the Construction General Permit. Call the contractor to determine if the NOI process has been started. If not, notify the contractor verbally of this requirement and the violation. Work cannot proceed on the site until a Notice of Intent (NOI) for coverage under the 2012 Construction General Permit has been approved by USEPA. The inspector may choose to print instructions on how to file an NOI and meet with the contractor to review these. Issue a written Stop Work Order until the NOI has been approved by USEPA.

Once it has been determined that the site is in compliance with the 2012 Construction General Permit, the site inspection process can continue. The Construction Site Inspection process shall include the following:

1. Plan the inspection before visiting the construction site
  - a. Obtain and review permits, site plans, previous inspection reports, and any other applicable information.
  - b. Print the approved NOI from the USEPA 2012 Construction General Permit NOI website, listed previously.
  - c. Inform the contractor of the planned site visit.
2. Meet with the contractor
  - a. Review the Construction SWPPP (if the site includes over one acre of disturbance) or other document, as required by the municipality's legal authority. Compare BMPs in the approved site plans with those shown in the SWPPP.
  - b. Review the project's approved NOI and confirm that information shown continues to be accurate.
  - c. Get a general overview of the project from the contractor.
  - d. Review inspections done by the contractor.
  - e. Review the status of any issues or corrective actions noted in previous inspection reports.
  - f. Discuss any complaints or incidents since the last meeting.
3. Inspect perimeter controls
  - a. Examine perimeter controls to determine if they are adequate, properly installed, and properly maintained.
  - b. For each structural BMP, check structural integrity to determine if any portion of the BMP needs to be replaced or requires maintenance.
4. Inspect slopes and temporary stockpiles
  - a. Determine if sediment and erosion controls are effective.
  - b. Look for slumps, rills, and tracking of stockpiled materials around the site.
5. Compare BMPs in the site plan with the construction site conditions

- a. Determine whether BMPs are in place as specified in the site plan, and if the BMPs have been adequately installed and maintained.
- b. Note any areas where additional BMPs may be needed which are not specified in the site plans.
6. Inspect site entrances/exits
  - a. Determine if there has been excessive tracking of sediment from the site.
  - b. Look for evidence of additional entrances/exits which are not on the site plan and are not properly stabilized.
7. Inspect sediment basins
  - a. Look for signs that sediment has accumulated beyond 50% of the original capacity of the basin.
8. Inspect pollution prevention and good housekeeping practices
  - a. Inspect trash areas and material storage/staging areas to ensure that materials are properly maintained and that pollutant sources are not exposed to rainfall or runoff.
  - b. Inspect vehicle/equipment fueling and maintenance areas for the presence of spill control measures and for evidence of leaks or spills.
9. Inspect discharge points and downstream, off-site areas
  - a. Walk down the street and/or in other directions off-site to determine if erosion and sedimentation control measures are effective in preventing off-site impacts.
  - b. Inspect down-slope catch basins to determine if they are protected, and identify whether sediment buildup has occurred.
10. Meet with the contactor again prior to leaving
  - a. Discuss the effectiveness of current controls and whether modifications are needed.
  - b. Discuss possible violations or concerns noted during the site inspection, including discrepancies between approved site plans, the SWPPP, and/or the implementation of stormwater controls.
  - c. Agree on a schedule for addressing all discrepancies, and schedule a follow-up inspection.
11. Provide a written copy of the inspection report to the contractor.
12. Follow up, as determined, and provide copy of subsequent inspection to the contractor.
13. Use Stop Work orders, as needed, until compliance with the 2012 Construction General Permit and/or other document, as required by the municipality's legal authority, can be achieved.

#### *Attachments*

1. Construction Site Stormwater Inspection Report

#### *Related Standard Operating Procedures*

1. SOP 9, Inspecting Constructed Best Management Practices



(continued)

	<b>BMP Description</b>	<b>Installed and Operating Properly?</b>	<b>Corrective Action Needed</b>
3		Yes <input type="checkbox"/> No <input type="checkbox"/>	
4		Yes <input type="checkbox"/> No <input type="checkbox"/>	
5		Yes <input type="checkbox"/> No <input type="checkbox"/>	
6		Yes <input type="checkbox"/> No <input type="checkbox"/>	
7		Yes <input type="checkbox"/> No <input type="checkbox"/>	
8		Yes <input type="checkbox"/> No <input type="checkbox"/>	
9		Yes <input type="checkbox"/> No <input type="checkbox"/>	
10		Yes <input type="checkbox"/> No <input type="checkbox"/>	
11		Yes <input type="checkbox"/> No <input type="checkbox"/>	
12		Yes <input type="checkbox"/> No <input type="checkbox"/>	
13		Yes <input type="checkbox"/> No <input type="checkbox"/>	
14		Yes <input type="checkbox"/> No <input type="checkbox"/>	
15		Yes <input type="checkbox"/> No <input type="checkbox"/>	
16		Yes <input type="checkbox"/> No <input type="checkbox"/>	
17		Yes <input type="checkbox"/> No <input type="checkbox"/>	
18		Yes <input type="checkbox"/> No <input type="checkbox"/>	
19		Yes <input type="checkbox"/> No <input type="checkbox"/>	
20		Yes <input type="checkbox"/> No <input type="checkbox"/>	

**Erosion and Sedimentation Control**

Document any of the following issues found on the construction site, and the corrective action(s) required for each.

Issue	Status	Corrective Action Needed
Have all ESC features been constructed before initiating other construction activities?	Yes <input type="checkbox"/> No <input type="checkbox"/>	
Is the contractor inspecting and maintaining ESC devices regularly?	Yes <input type="checkbox"/> No <input type="checkbox"/>	
Is existing vegetation maintained on the site as long as possible?	Yes <input type="checkbox"/> No <input type="checkbox"/>	
Is construction staged so as to minimize exposed soil and disturbed areas?	Yes <input type="checkbox"/> No <input type="checkbox"/>	
Are disturbed areas restored as soon as possible after work is completed?	Yes <input type="checkbox"/> No <input type="checkbox"/>	
Is clean water being diverted away from the construction site?	Yes <input type="checkbox"/> No <input type="checkbox"/>	
Are sediment traps and sediment barriers cleaned regularly?	Yes <input type="checkbox"/> No <input type="checkbox"/>	
Are vegetated and wooded buffers protected and left undisturbed?	Yes <input type="checkbox"/> No <input type="checkbox"/>	
Are soils stabilized by mulching and/or seeding when they are exposed for a long time?	Yes <input type="checkbox"/> No <input type="checkbox"/>	
Has vegetation been allowed to establish itself before flows are introduced to channels?	Yes <input type="checkbox"/> No <input type="checkbox"/>	
Is regular, light watering used for dust control?	Yes <input type="checkbox"/> No <input type="checkbox"/>	
Is excessive soil compaction with heavy machinery avoided, to the extent possible?	Yes <input type="checkbox"/> No <input type="checkbox"/>	

(continued)

Issue	Status	Corrective Action Needed
Are erosion control blankets used when seeding slopes?	Yes <input type="checkbox"/> No <input type="checkbox"/>	
Are trees and vegetation that are to be retained during construction adequately protected?	Yes <input type="checkbox"/> No <input type="checkbox"/>	
Are areas designated as off-limits to construction equipment flagged or easily distinguishable?	Yes <input type="checkbox"/> No <input type="checkbox"/>	
If excavated topsoil has been salvaged and stockpiled for later use on the project, are stockpiles adequately protected?	Yes <input type="checkbox"/> No <input type="checkbox"/>	
Are temporary slope drains or chutes used to transport water down steep slopes?	Yes <input type="checkbox"/> No <input type="checkbox"/>	
Do all entrances to the storm sewer system have adequate protection?	Yes <input type="checkbox"/> No <input type="checkbox"/>	

**Overall Site Conditions**

Document any of the following issues found on the construction site, and the corrective action(s) required for each.

Issue	Status	Corrective Action Needed
Are slopes and disturbed areas not being actively worked properly stabilized?	Yes <input type="checkbox"/> No <input type="checkbox"/>	
Are material stockpiles covered or protected when not in use?	Yes <input type="checkbox"/> No <input type="checkbox"/>	
Are natural resource areas protected with sediment barriers or other BMPs?	Yes <input type="checkbox"/> No <input type="checkbox"/>	
Are perimeter controls and sediment barriers installed and maintained?	Yes <input type="checkbox"/> No <input type="checkbox"/>	



(continued)

Issue	Status	Corrective Action Needed
Are discharge points and receiving waters free of sediment deposits and turbidity?	Yes <input type="checkbox"/> No <input type="checkbox"/>	
Are storm drain inlets properly protected?	Yes <input type="checkbox"/> No <input type="checkbox"/>	
Is there evidence of sediment being tracked into streets?	Yes <input type="checkbox"/> No <input type="checkbox"/>	
Is trash/litter from the construction site collected and placed in dumpsters?	Yes <input type="checkbox"/> No <input type="checkbox"/>	
Are vehicle/equipment fueling and maintenance areas free of spills and leaks?	Yes <input type="checkbox"/> No <input type="checkbox"/>	
Are potential stormwater contaminants protected inside or under cover?	Yes <input type="checkbox"/> No <input type="checkbox"/>	
Is dewatering from site properly controlled?	Yes <input type="checkbox"/> No <input type="checkbox"/>	
Are portable restroom facilities properly sited and maintained?	Yes <input type="checkbox"/> No <input type="checkbox"/>	
Are all hazardous materials and wastes stored in accordance with local regulations?	Yes <input type="checkbox"/> No <input type="checkbox"/>	

**Non-Compliance Actions**

The municipality shall provide the site operator with a copy of this report, and notice of the corrective action(s) to be taken. The site operator shall have thirty days from the receipt of the notice to commence curative action of the violation.

## **SOP 6: EROSION AND SEDIMENTATION CONTROL**

Erosion and sedimentation from land-disturbing human activities can be a significant source of stormwater pollution. This Standard Operating Procedure describes methods for reducing or eliminating pollutant loading from such activities.

### *Controlling Erosion and Sediment through Design and Planning*

Prevention of erosion and sedimentation is preferable to installing treatment devices. Consistent application and implementation of the following guidelines during the design and review phases can prevent erosion and sedimentation:

1. Avoid sensitive areas, steep slopes, and highly erodible soils to the maximum extent possible when developing site plans.
2. Identify potential problem areas before the site plan is finalized and approved.
3. Plan to use sediment barriers along contour lines, with a focus on areas where short-circuiting (i.e., flow around the barrier) may occur.
4. Use berms at the top of a steep slopes to divert runoff away from the slope's edge.
5. Design trapezoidal or parabolic vegetated drainage channels, not triangular.
6. Use vegetated channels with rip rap check dams, instead of impervious pavement or concrete, to reduce the water velocity of the conveyance system.
7. Design a check dam or sediment forebay with level spreader at the exit of outfalls to reduce water velocity of the discharge and collect sediment.
8. Use turf reinforcement matting to stabilize vegetated channels, encourage vegetation establishment, and withstand flow velocities without scouring the base of the channel.
9. Plan open channels to follow land contours so natural drainage is not disrupted.
10. Use organic matting for temporary slope stabilization and synthetic matting for permanent stabilization.
11. Provide a stable channel, flume, or slope drain where it is necessary to carry water down slopes.

### *Controlling Erosion and Sediment on Construction Sites*

During the construction phase, it is important to inspect active sites regularly to ensure that practices are consistent with approved site plans and the site's Stormwater Pollution Prevention Plan (SWPPP) or other document, as required by the municipality's legal authority. The following guidelines apply:

1. Erosion and sediment control features should be constructed before initiating activities that remove vegetated cover or otherwise disturb the site. These shall be installed consistent with the approved site plans and with manufacturer's instructions.
2. Erosion and sediment control devices shall be inspected by the contractor regularly, and maintained as needed to ensure function.

3. In the SWPPP or other document, the contractor shall clearly identify the party responsible for maintaining erosion and sediment control devices.
4. An inspection should be completed of active construction sites every month, at a minimum, to check the status of erosion and sedimentation controls. Refer to SOP 5, "Construction Site Inspection", for construction site stormwater inspection procedures.
5. Existing vegetation should be maintained on site as long as possible.
6. Construction should proceed progressively on the site in order to minimize exposed soil, and disturbed areas should be restored as soon as possible after work has been completed.
7. Stockpiles shall be stabilized by seeding or mulching if they are to remain for more than two weeks.
8. Disturbed areas shall be protected from stormwater runoff by using protective Best Management Practices (BMPs).
9. Clean water shall be diverted away from disturbed areas on construction sites to prevent erosion and sedimentation.
10. Sediment traps and sediment barriers should be cleaned out regularly to reduce clogging and maintain design function.
11. Vegetated and wooded buffers shall be protected.
12. Soils shall be stabilized by mulching and/or seeding when they would be exposed for more than one week during the dry season, or more than two days during the rainy season.
13. Vegetation shall be allowed to establish before introducing flows to channels.
14. Regular light watering shall be used for dust control, as this is more effective than infrequent heavy watering.
15. Excessive soil compaction with heavy machinery shall be avoided, to the extent possible.
16. Construction activities during months with higher runoff rates shall be limited, to the extent possible.

#### *Controlling Erosion and Sediment by Proper Maintenance of Permanent BMPs*

Many construction phase BMPs can be integrated into the final site design, but ongoing inspection and maintenance are required to ensure long-term function of any permanent BMP. Refer to SOP 9, "Inspection of Constructed Best Management Practices", for more information. The following guidelines summarize the requirements for long-term maintenance of permanent BMPs.

1. Responsibility for maintaining erosion and sediment control devices shall be clearly identified.
2. Erosion and sediment control devices shall be inspected following heavy rainfall events to ensure they are working properly.
3. Erosion control blankets shall be utilized when seeding slopes.
4. Vegetated and wooded buffers shall be protected, and left undisturbed to the extent possible.
5. Runoff shall not be diverted into a sensitive area unless this has been specifically approved.
6. Sedimentation basins shall be cleaned out once sediment reaches 50% of the basin's design capacity.
7. Snow shall not be plowed into, or stored within, retention basins, rain gardens, or other BMPs.



**Erosion and Sediment Control (ESC) on Construction Sites**

Document any of the following issues found on the construction site, and the corrective action(s) required for each.

Issue	Status	Corrective Action Needed
Have all ESC features been constructed before initiating other construction activities?	Yes <input type="checkbox"/> No <input type="checkbox"/>	
Is the contractor inspecting and maintaining ESC devices regularly?	Yes <input type="checkbox"/> No <input type="checkbox"/>	
Is existing vegetation maintained on the site as long as possible?	Yes <input type="checkbox"/> No <input type="checkbox"/>	
Is construction staged so as to minimize exposed soil and disturbed areas?	Yes <input type="checkbox"/> No <input type="checkbox"/>	
Are disturbed areas restored as soon as possible after work is completed?	Yes <input type="checkbox"/> No <input type="checkbox"/>	
Is clean water being diverted away from the construction site?	Yes <input type="checkbox"/> No <input type="checkbox"/>	
Are sediment traps and sediment barriers cleaned regularly?	Yes <input type="checkbox"/> No <input type="checkbox"/>	
Are vegetated and wooded buffers protected and left undisturbed?	Yes <input type="checkbox"/> No <input type="checkbox"/>	
Are soils stabilized by mulching and/or seeding when they are exposed for a long time?	Yes <input type="checkbox"/> No <input type="checkbox"/>	
Has vegetation been allowed to establish itself before flows are introduced to channels?	Yes <input type="checkbox"/> No <input type="checkbox"/>	
Is regular, light watering used for dust control?	Yes <input type="checkbox"/> No <input type="checkbox"/>	
Is excessive soil compaction with heavy machinery avoided, to the extent possible?	Yes <input type="checkbox"/> No <input type="checkbox"/>	

(continued)

Issue	Status	Corrective Action Needed
Are erosion control blankets used when seeding slopes?	Yes <input type="checkbox"/> No <input type="checkbox"/>	
Are trees and vegetation that are to be retained during construction adequately protected?	Yes <input type="checkbox"/> No <input type="checkbox"/>	
Are areas designated as off-limits to construction equipment flagged or easily distinguishable?	Yes <input type="checkbox"/> No <input type="checkbox"/>	
If excavated topsoil has been salvaged and stockpiled for later use on the project, are stockpiles adequately protected?	Yes <input type="checkbox"/> No <input type="checkbox"/>	
Are temporary slope drains or chutes used to transport water down steep slopes?	Yes <input type="checkbox"/> No <input type="checkbox"/>	
Do all entrances to the storm sewer system have adequate protection?	Yes <input type="checkbox"/> No <input type="checkbox"/>	

**Non-Compliance Actions**

The municipality shall provide the site operator with a copy of this report, and notice of the corrective action(s) to be taken. The site operator shall have thirty days from the receipt of the notice to commence curative action of the violation.

8. Easements and service routes shall be maintained, to enable maintenance equipment to access BMPs for regular cleaning.

*Related Standard Operating Procedures*

1. SOP 5, Construction Site Inspection
2. SOP 9, Inspection of Constructed Best Management Practices

# SOP 7: Fuel and Oil Handling

## Introduction

Spills, leaks, and overfilling can occur during handling of fuels and petroleum-based materials, representing a potential source of stormwater pollution, even in small volumes. The goal of this written Standard Operating Procedure (SOP) is to provide guidance to municipal employees on a variety of ways by which fuels and petroleum-based materials can be delivered, as well as steps to be taken when petroleum products (such as waste oil) are loaded onto vehicles for offsite disposal or recycling. Delivery, unloading, and loading of waste oils are hereafter referred to as “handling.” Attached is a fuel delivery form checklist.

## Procedures

The Town of Foxborough will implement the following fuel and oil handling procedures to help reduce the discharge of pollutants from the MS4:

### General Guidelines

For all manners of fuel and oil handling described below, a member of the facility’s Pollution Prevention Team (if the facility has a SWPPP) or another knowledgeable person familiar with the facility should be present during handling procedures. This person should ensure that the following are observed:

- There is no smoking while fuel handling is in process or underway.
- Sources of flame are kept away while fuel handling is being completed. This includes smoking, lighting matches, carrying any flame, or carrying a lighted cigar, pipe, or cigarette.
- The delivery vehicle’s hand brake is set and wheels are chocked while the activity is being completed.
- Catch basins and drain manholes are adequately protected.
- No tools are to be used that could damage fuel or oil containers or the delivery vehicle.
- No flammable liquid should be unloaded from any motor vehicle while the engine is operating, unless the engine of the motor vehicle is required to be used for the operation of a pump.
- Ensure that local traffic does not interfere with fuel transfer operations. If it does, make appropriate accommodations.
- The attending persons should watch for any leaks or spills:
  - Any small leaks or spills should be immediately stopped, and spilled materials absorbed and disposed of properly. Follow the procedures in SOP 4: Spill Response and Cleanup.
  - In the event of a large spill or one that discharges to surface waters or an engineered storm drain system, the facility representative should activate the facility’s Stormwater Pollution Prevention Plan (SWPPP) and report the incident as specified in the document.

### Delivery by Bulk (Tanker) Truck

Procedures for the delivery of bulk fuel should include the following:

- The truck driver should check in with the facility upon arrival.
- The facility representative should ensure that the appropriate spill cleanup and response equipment and personal protective equipment are readily available and easily accessible. Refer to SOP 4: Spill Response and Cleanup for examples of spill cleanup and response materials.
- The facility representative should check to ensure that the amount of delivery does not exceed the available capacity of the tank.



- A level gauge can be used to verify the level in the tank.
- If a level gauge is not functioning or is not present on the tank, the tank should be stick tested prior to filling.
- The truck driver and the facility representative should both remain with the vehicle during the delivery process.
- The truck driver and the facility representative should inspect all visible lines, connections, and valves for leaks.
- When delivery is complete and the hoses are removed, buckets should be placed underneath connection points to catch drippings.
- The delivery vehicle should be inspected prior to departure to ensure that the hose is disconnected from the tank.
- The facility representative should inspect the fuel tank to verify that no leaks have occurred, or that any leaked or spilled material has been cleaned and disposed of properly.
- The facility representative should gauge tank levels to ensure that the proper amount of fuel is delivered, and collect a receipt from the truck driver.

### **Delivery of Drummed Materials**

Drummed materials may include motor oil, hydraulic fluid, transmission fluid, or waste oil from another facility (as approved). Procedures for the delivery of drummed materials should include the following:

- The truck driver should check in with the facility upon arrival.
- The facility representative should ensure that the appropriate spill cleanup and response equipment and personal protective equipment are readily available and easily accessible. Refer to SOP 4: Spill Response and Cleanup for examples of spill cleanup and response materials. The facility representative should closely examine the shipment for damaged drums.
  - If damaged drums are found, they should be closely inspected for leaks or punctures.
  - Breached drums should be removed to a dry, well-ventilated area and the contents transferred to other suitable containers.
  - Drums should be disposed of in accordance with all applicable regulations.
- Drummed materials should not be unloaded outdoors during wet weather events.
- The truck driver and the facility representative should both remain with the vehicle during the delivery process.
- Drums should be handled and unloaded carefully to prevent damage.
- Upon completion of unloading, the facility representative should inspect the unloading point and the drums to verify that no leaks have occurred, that any leaked or spilled material has been cleaned up and disposed of properly, and that the unloaded drums are not leaking.
- The facility representative should check to ensure that the proper amount of fuel or other material is delivered, and collect a receipt from the truck driver.

### **Removal of Waste Oil from the Facility**

When waste oil or similar oil products need to be removed from the premises, only haulers certified to transport waste oil should be utilized. Procedures should include the following:

- The disposal truck driver should check in with the facility upon arrival.
- The facility representative should ensure that the appropriate spill cleanup and response equipment and personal protective equipment are readily available and easily accessible. Refer to SOP 4: Spill

Response and Cleanup for examples of spill cleanup and response materials. The truck driver and the facility representative should both remain with the vehicle during the tank draining process.

- When draining is complete and the hoses are removed, buckets should be placed underneath connection points to catch drippings.
- The facility representative should inspect the loading point and the tank to verify that no leaks have occurred, or that any leaked or spilled material has been cleaned up and disposed of properly.
- The facility representative should collect a receipt from the truck driver.
- When draining bulk oil tanks:
  - The facility representative should verify that the volume of waste oil in the tank does not exceed the available capacity of the disposal hauler's vehicle.
  - The disposal hauler vehicle should be inspected prior to departure to ensure that the hose is disconnected from the tank.

### **Employee Training**

- Employees who handle or deliver fuel and/or oil are trained once per year on proper procedures.
- Employees are also trained on stormwater pollution prevention, illicit discharge detection and elimination (IDDE) procedures, and spill and response procedures.
- If services are contracted, the contractor should be given a copy of this and any applicable SOPs to ensure compliance with MS4 regulations.

### **Attachments**

1. Fuel Delivery Checklist

### **Related Standard Operating Procedures**

- SOP 4: Spill Response and Cleanup

**FUEL DELIVERY FORM**  
**TOWN OF FOXBOROUGH, MASSACHUSETTS**

**Date:** \_\_\_\_\_  
**Time of Arrival:** \_\_\_\_\_  
**Time of Departure:** \_\_\_\_\_  
**Truck Number:** \_\_\_\_\_  
**Name of Truck Driver:** \_\_\_\_\_  
**Name of Town Employee:** \_\_\_\_\_

**BEFORE UNLOADING:**

Is all spill response equipment and personal protective equipment in place?

Yes  No

In the case of bulk fuel delivery, does tank capacity exceed the amount of delivery?

Yes  No  N/A

In the case of drum fuel delivery, are all drums free of leaks and punctures?

Yes  No  N/A

**COMMENCE UNLOADING. REMAIN WITH VEHICLE AT ALL TIMES.**

**AFTER UNLOADING IS COMPLETE:**

Have all fuel containers, including the vehicle, been inspected for leaks?

Yes  No

Has the ground at the unloading point been inspected for evidence of leaks?

Yes  No

If there are any leaks or spills, has the material been properly cleaned?

Yes  No

Has the correct amount of fuel been delivered?

Yes  No

Has a receipt been collected?

Yes  No

**DELIVERY IS COMPLETE.**

# SOP 9: Inspection and Maintenance of Structural Stormwater Best Management Practices (BMPs)

## Introduction

Best Management Practices (BMPs) are policies, procedures and structures designed to reduce stormwater pollution, prevent contaminant discharges to natural water bodies, and reduce stormwater facility maintenance costs. Structural BMPs are permanent site features designed to treat stormwater before infiltrating it to the subsurface or discharging it to a surface water body. Regular inspection and maintenance of structural stormwater BMPs is critical for these engineered systems to function as designed (e.g., provide benefits to water quality, groundwater recharge, and peak flow attenuation).

This Standard Operating Procedure (SOP) provides general inspection and maintenance frequencies and procedures for eight common structural stormwater BMPs, including:

1. Bioretention Areas and Rain Gardens
2. Constructed Stormwater Wetlands
3. Extended Dry Detention Basins
4. Proprietary Media Filters
5. Sand and Organic Filters
6. Wet Basins
7. Dry Wells
8. Infiltration Basins

This SOP is based on the Massachusetts Stormwater Handbook and is not intended to replace the stormwater BMP Operation and Maintenance guidance contained in the Handbook. This SOP is also not intended to replace the Stormwater BMP Operation and Maintenance (O&M) Plan required by the Massachusetts Wetlands Protection Act, Order of Conditions.

The Department of Public Works is responsible for inspection and maintenance of structural stormwater BMPs and other stormwater infrastructure in the Town of Foxborough. A list of existing structural stormwater BMPs is included in the attachments, along with inspection and maintenance checklists for each type of BMP.

Structural stormwater BMPs will be inspected annually at a minimum. Inspection checklists for each type of structural BMP are provided in the attachments.

## Procedures

### **Bioretention Areas and Rain Gardens**

Bioretention areas and rain gardens are shallow depressions filled with sandy soil, topped with a thick layer of mulch, and planted with dense native vegetation. There are two types of bioretention cells:

1. Filtering bioretention area: Areas that are designed solely as an organic filter.
2. Exfiltration bioretention area: Areas that are configured to recharge groundwater in addition to acting as a filter.

***Inspection and Maintenance***

Regular inspection and maintenance are important to prevent against premature failure of bioretention areas or rain gardens. Regular inspection and maintenance of pretreatment devices and bioretention cells for sediment buildup, structural damage and standing water can extend the life of the soil media.

**Maintenance Schedule: Bioretention Areas and Rain Gardens**

Activity	Time of Year	Frequency
Inspect for soil erosion and repair	Year round	Monthly
Inspect for invasive species and remove if present	Year round	Monthly
Remove trash	Year round	Monthly
Mulch Void Areas	Spring	Annually
Remove dead vegetation	Fall and spring	Bi-annually
Replace dead vegetation	Spring	Annually
Prune	Spring or fall	Annually
Replace all media and vegetation	Late spring/early summer	As needed

When failure is discovered, excavate the bioretention area, scarify the bottom and sides, replace the filter fabric and soil, replant vegetation, and mulch the surface.

Never store snow within a bioretention area or rain garden. This would prevent the recharge and water quality treatment of ground water.

**Constructed Stormwater Wetlands**

Constructed stormwater wetlands maximize pollutant removal from stormwater through the use of wetland vegetation uptake, retention, and settling. Constructed storm water wetlands must be used in conjunction with other BMPs, such as sediment forebays.

***Inspection and Maintenance***

Regular inspection and maintenance are important for the health of constructed stormwater wetlands. They help identify the need for replacement of vegetation and media, detect potentially harmful invasive species, and ensure the overall health of the wetland.

**Maintenance Schedule, Constructed Stormwater Wetlands: Years 0-3**

Activity	Time of Year	Frequency
Inspect for invasive species and remove if present	Year round	Monthly
Record and Map:	Year round	Annually
Types and distribution of dominant wetland plants	Year round	Bi-annually
Presence and distribution of planted wetland species	Spring	Annually
Presence and distribution of invasive species	Fall and spring	Bi-annually
Indications other species are replacing planted wetland species	Spring	Annually
Percent of standing water that is not vegetated	Spring or fall	Annually
Replace all media and vegetation	Late spring/early summer	As needed

Stability of original depth zones and micro-topographic features		
Accumulation of sediment in the forebay and micropool and survival rate of plants		

**Maintenance Schedule, Constructed Stormwater Wetlands: Years 4-Lifetime**

Activity	Time of Year	Frequency
Inspect for invasive species and remove if present	Year round	Monthly
Clean forebays	Year round	Annually
Clean sediment in basin/wetland system	Year round	Once every 10 years
Mulch Void Areas	Spring	Annually
Remove dead vegetation	Fall and spring	Bi-annually
Replace dead vegetation	Spring	Annually
Prune	Spring or fall	Annually
Replace all media and vegetation	Late spring/early Summer	As needed

Never store snow within a constructed stormwater wetland. This would prevent required water quality treatment and the recharge of groundwater.

**Extended Dry Detention Basins**

Extended dry detention basins are designed to control both stormwater quantity and quality. These BMPs are designed to hold stormwater for at least 24 hours, allowing solids to settle and reducing local and downstream flooding. Pretreatment is required to reduce the potential for overflow clogging. The outflow may be designed as either fixed or adjustable. Additional nutrient removal may be achieved by a micropool or shallow marsh.

***Inspection and Maintenance***

Annual inspection of extended dry detention basins is required to ensure that the basins are operating properly. Potential problems include: erosion within the basin and banks, tree growth on the embankment, damage to the emergency spillway, and sediment accumulation around the outlet. Should any of these problems be encountered, necessary repairs should be made immediately.

**Maintenance Schedule: Extended Dry Detention Basins**

Activity	Time of Year	Frequency
Inspect basins	Spring and fall	Bi-annually and during and after major storms
Examine outlet structure for clogging or high outflow release velocities	Spring and fall	Bi-annually
Mow upper stage, side slopes, embankment and emergency spillway	Spring through fall	Bi-annually
Remove trash and debris	Spring	Bi-annually
Remove sediment from basin	Year round	At least once every 5 years

**Proprietary Media Filters**

Media Filters are designed to reduce total suspended solids and other target pollutants, such as organics, heavy metals, or nutrients – these materials are sorbed onto the filter media, which is contained in a concrete structure. The substrate used as filter media depends on the target pollutants, and may consist of leaf compost, pleated fabric, activated charcoal, perlite, amended sand in combination with perlite, and zeolite. Two types of Media Filters are manufactured: Dry media filters, which are designed to dewater within 72 hours, and wet media filters, which maintain a permanent pool of water as part of the treatment system.

***Inspection and Maintenance***

Maintenance in accordance with the manufacturer’s requirements is necessary to ensure stormwater treatment. Inspection or maintenance of the concrete structure may require OSHA confined space training. Dry media filters are required to dewater in 72 hours, thus preventing mosquito and other insect breeding. Proper maintenance is essential to prevent clogging. Wet media filters require tight fitting seals to keep mosquitoes and other insects from entering and breeding in the permanent pools. Required maintenance includes routine inspection and treatment.

**Maintenance Schedule: Proprietary Media Filters**

Activity	Time of Year	Frequency
Inspect for standing water, trash, sediment and clogging	Per manufacturer’s schedule	Bi-annually (minimum)
Remove trash and debris	N/A	Each inspection
Examine to determine if system drains in 72 hours	Spring, after large storm	Annually
Inspect filtering media for clogging	Per manufacturer’s schedule	Per manufacturer’s schedule

**Sand and Organic Filters**

Sand and organic filters, also known as filtration basins, are intended for stormwater quality control rather than quantity control. These filters improve water quality by removing pollutants through a filtering media and settling pollutants on top of the sand bed and/or in a pretreatment basin. Pretreatment is required to prevent filter media from clogging. Runoff from the filters is typically discharged to another BMP for additional treatment.

***Inspection and Maintenance***

If properly maintained, sand and organic filters have a long life. Maintenance requirements of the filters include raking the sand and removing sediment, trash, and debris from the surface of the BMP. Over time, fine sediments will penetrate deep into the sand requiring replacement of several inches or the entire sand layer. Discolored sand is an indicator of the presence of fine sediments, suggesting that the sand should be replaced.

**Maintenance Schedule: Sand and Organic Filters**

Activity	Frequency
Inspect filters and remove debris	After every major storm for the first 3 months after construction completion. Every 6 months thereafter.

**Wet Basins**

Wet basins are intended to treat stormwater quality through the removal of sediments and soluble pollutants. A permanent pool of water allows sediments to settle and removes the soluble pollutants, including some metals and nutrients. Additional dry storage is required to control peak discharges during large storm events. If properly designed and maintained, wet basins can add fire protection, wildlife habitats, and aesthetic values to a property.

***Inspection and Maintenance***

To ensure proper operation, wet basin outfalls should be inspected for evidence of clogging or excessive outfall releases. Potential problems to investigate include erosion within the basin and banks, damage to the emergency spillway, tree growth on the embankment, sediment accumulation around the outlet, and the emergence of invasive species. Should any of these problems be encountered, perform repairs immediately. An on-site sediment disposal area will reduce sediment removal costs.

**Maintenance Schedule: Wet Basins**

Activity	Time of Year	Frequency
Inspect wet basins	Spring and/or fall	Annually (Minimum)
Mow upper stage, side slopes, embankment and emergency spillway	Spring through fall	Bi-annually (Minimum)
Remove sediment, trash and debris	Spring through fall	Bi-annually (Minimum)
Remove sediment from basin	Year round	As required, but at least once every 10 years

**Dry Wells**

Dry wells are used to infiltrate uncontaminated runoff. These BMPs should never be used to infiltrate stormwater or runoff that has the potential to be contaminated with sediment and other pollutants. Dry wells provide groundwater recharge and can reduce the size and cost required of downstream BMPs or storm drains. However, they are only applicable in drainage areas of less than one acre and may experience high failure rates due to clogging.



***Inspection and Maintenance***

Proper dry well function depends on regular inspection. Clogging has the potential to cause high failure rates. The water depth in the observation well should be measured at 24 and 48 hour intervals after a storm and the clearance rate calculated. The clearance rate is calculated by dividing the drop in water level (inches) by the time elapsed (hours).

**Maintenance Schedule: Dry Wells**

Activity	Frequency
Inspect dry wells	After every major storm for the first 3 months after construction completion. Annually thereafter.

**Infiltration Basins**

Infiltration basins are designed to contain stormwater and provide groundwater recharge. Pollution prevention and pretreatment are required to ensure that contaminated stormwater is not infiltrated. Infiltration basins reduce local flooding and preserve the natural water balance of the site. High failure rates, however, often occur due to improper siting, inadequate pretreatment, poor design, and lack of maintenance.

***Inspection and Maintenance***

Regular maintenance is required to prevent clogging, which results in infiltration basin failure. Clogging may be due to upland sediment erosion, excessive soil compaction, or low spots. Inspections should include signs of differential settlement, cracking, erosion, leakage in the embankments, tree growth on the embankments, riprap condition, sediment accumulation, and turf health.

**Maintenance Schedule: Infiltration Basins**

Activity	Time of Year	Frequency
Preventative maintenance	Spring and fall	Bi-annually
Inspection	Spring and fall	After every major storm for the first 3 months after construction completion. Bi-annually thereafter and discharges through the high outlet orifice.
Mow/rake buffer area, side slopes and basin bottom	Spring and fall	Bi-annually
Remove trash, debris and organic matter	Spring and fall	Bi-annually

**Employee Training**

- Employees who perform inspection or maintenance on structural BMPs are trained once per year on proper procedures.
- If services are contracted, the contractor should be given a copy of this and any applicable SOPs to ensure compliance with MS4 regulations.

**Attachments**

1. Structural BMP Inventory Template
2. Structural BMP Inspection and Maintenance Checklists

## SOP 10: LOCATING ILLICIT DISCHARGES

### *Introduction*

An “illicit discharge” is any discharge to an engineered storm drain system that is not composed entirely of stormwater unless the discharge is defined as an allowable non-stormwater discharge under the 2003 Massachusetts MS4 Permit. Illicit discharges may enter the engineered storm drain system through direct or indirect connections, such as: cross-connections of sewer services to engineered storm drain systems; leaking septic systems; intentional discharge of pollutants to catch basins; combined sewer overflows; connected floor drains; and sump pumps connected to the system (under some circumstances). Illicit discharges can contribute high levels of pollutants, such as heavy metals, toxics, oil, grease, solvents, nutrients, and pathogens to receiving streams.

Illicit discharges can be located by several methods, including routine dry weather outfall inspections and catch basin inspections, which are described in detail in SOP 1, “Dry Weather Outfall Inspection” and SOP 3, “Catch Basin Inspection and Cleaning”, respectively, as well as from citizen reports.

This SOP assumes that the municipality has legal authority (i.e., a bylaw or ordinance) in place, per the requirements of the 2003 Massachusetts MS4 Permit, to prohibit the connection of non-stormwater discharges into the storm drain system. The authority or department for addressing illicit discharge reports would be clearly identified in the municipality’s legal authority. In Massachusetts, this is typically a combination of the Board of Health, the Department of Public Works (or Highway Department), and the local sanitary sewer department or commission. In some communities, the Conservation Commission may also play a role. This SOP refers to “appropriate authority” generically to reflect differences in how municipalities have identified these roles.

### *Identifying Illicit Discharges*

The following are often indicators of an illicit discharge from stormwater outfall:

1. Foam: indicator of upstream vehicle washing activities, or an illicit discharge.
2. Oil sheen: result of a leak or spill.
3. Cloudiness: indicator of suspended solids such as dust, ash, powdered chemicals and ground up materials.
4. Color or odor: Indicator of raw materials, chemicals, or sewage.
5. Excessive sediment: indicator of disturbed earth of other unpaved areas lacking adequate erosion control measures.
6. Sanitary waste and optical enhancers (fluorescent dyes added to laundry detergent): indicator of the cross-connection of a sewer service.
7. Orange staining: indicator of high mineral concentrations.

Both bacteria and petroleum can create a sheen on the water surface. The source of the sheen can be differentiated by disturbing it, such as with a pole. A sheen caused by oil will remain intact and move in

a swirl pattern; a sheen caused by bacteria will separate and appear “blocky”. Bacterial sheen is not a pollutant but should be noted.

### *Citizen Call in Reports*

Reports by residents and other users of a water body can be effective tools in identifying the presence of illicit discharges. Many communities have set up phone hotlines for this purpose, or have provided guidance to local police departments and dispatch centers to manage data reported in this manner. Municipal employees and the general public should receive education to help identify the signs of illicit discharges and should be informed how to report such incidents.

When a call is received about a suspected illicit discharge, the attached IDDE Incident Tracking Sheet shall be used to document appropriate information. Subsequent steps for taking action to trace, document, and eliminate the illicit discharge are described in the following sections.

Potential illicit discharges reported by citizens should be reviewed on an annual basis to locate patterns of illicit discharges, identify high-priority catchments, and evaluate the call-in inspection program.

### *Tracing Illicit Discharges*

Whenever an illicit discharge is suspected, regardless of how it was identified, the attached IDDE Incident Tracking Sheet should be utilized. The Incident Tracking Sheet shall be provided to the appropriate authority (i.e., Board of Health, Department of Public Works, etc.), which shall promptly investigate the reported incident.

If the presence of an illicit discharge is confirmed by the authority, but its source is unidentified, additional procedures to determine the source of the illicit discharge should be completed.

1. Review and consider information collected when illicit discharge was initially identified, for example, the time of day and the weather conditions for the previous 72 hours. Also consider and review past reports or investigations of similar illicit discharges in the area.
2. Obtain storm drain mapping for the area of the reported illicit discharge. If possible, use a tracking system that can be linked to your system map, such as GIS.
3. Document current conditions at the location of the observed illicit discharge point, including odors, water appearance, estimated flow, presence of floatables, and other pertinent information. Photograph relevant evidence.
4. If there continues to be evidence of the illicit discharge, collect water quality data using the methods described in SOP 13, “Water Quality Screening in the Field”. This may include using field test kits or instrumentation, or collecting analytical samples for full laboratory analysis.
5. Move upstream from the point of observation to identify the source of the discharge, using the system mapping to determine infrastructure, tributary pipes, and drainage areas that contribute. At each point, survey the general area and surrounding properties to identify potential sources of the illicit discharge. Document observations at each point on the IDDE Incident Tracking Sheet as well as with photographs.
6. Continue this process until the illicit discharge is no longer observed, which will define the boundaries of the likely source. For example if the illicit discharge is present in catch basin 137

but not the next upstream catch basin, 138, the source of the illicit discharge is between these two structures.

If the source of the illicit discharge could not be determined by this survey, consider using dye testing, smoke testing, or closed-circuit television inspection (CCTV) to locate the illicit discharge.

### Dye Testing

Dye testing is used to confirm a suspected illicit connection to a storm drain system. Prior to testing, permission to access the site should be obtained. Dye is discharged into the suspected fixture, and nearby storm drain structures and sanitary sewer manholes observed for presence of the dye. Each fixture, such as sinks, toilets, and sump pumps, should be tested separately. A third-party contractor may be required to perform this testing activity.

### Smoke Testing

Smoke testing is a useful method of locating the source of illicit discharges when there is no obvious potential source. Smoke testing is an appropriate tracing technique for short sections of pipe and for pipes with small diameters. Smoke added to the storm drain system will emerge in connected locations. A third-party contractor may be required to perform this testing activity.

### Closed Circuit Television Inspection (CCTV)

Televised video inspection can be used to locate illicit connections and infiltration from sanitary sewers. In CCTV, cameras are used to record the interior of the storm drain pipes. They can be manually pushed with a stiff cable or guided remotely on treads or wheels. A third-party contractor may be required to perform this testing activity.

If the source is located, follow steps for removing the illicit discharge. Document repairs, new sanitary sewer connections, and other corrective actions required to accomplish this objective. If the source still cannot be located, add the pipe segment to a future inspection program.

This process is demonstrated visually on the last page of this SOP.

### *Removing Illicit Discharges*

Proper removal of an illicit discharge will ensure it does not recur. Refer to Table SOP 10-1, attached for, for examples of the notification process.

In any scenario, conduct a follow up inspection to confirm that the illicit discharge has been removed. Suspend access to the storm drain system if an “imminent and substantial danger” exists or if there is a threat of serious physical harm to humans or the environment.

### *Attachments*

1. Illicit Discharge Incident Tracking Sheet

*Related Standard Operating Procedures*

1. SOP 1: Dry Weather Outfall Inspection
2. SOP 2: Wet Weather Outfall Inspection
3. SOP 3: Catch Basin Inspection
4. SOP 13: Using Field Test Kits For Outfall Screening
5. SOP 15: Private Drainage Connections

**Table SOP 10-1**

**Notification and Removal Procedures for Illicit Discharges  
 into the Municipal Separate Storm Sewer System**

<b>Financially Responsible</b>	<b>Source Identified</b>	<b>Enforcement Authority</b>	<b>Procedure to Follow</b>
Private Property Owner	One-time illicit discharge (e.g. spill, dumping, etc.)	Ordinance enforcement authority (e.g. Code Enforcement Officer)	<ul style="list-style-type: none"> <li>• Contact Owner</li> <li>• Issue Notice of Violation</li> <li>• Issue fine</li> </ul>
Private Property Owner	Intermittent or continuous illicit discharge from legal connection	Ordinance enforcement authority (e.g. Code Enforcement Officer)	<ul style="list-style-type: none"> <li>• Contact Owner</li> <li>• Issue Notice of Violation</li> <li>• Determine schedule for removal</li> <li>• Confirm removal</li> </ul>
Private Property Owner	Intermittent or continuous illicit discharge from illegal connection or indirect (e.g. infiltration or failed septic)	Plumbing Inspector or ordinance enforcement authority	<ul style="list-style-type: none"> <li>• Notify plumbing inspector</li> </ul>
Municipal	Intermittent or continuous illicit discharge from illegal connection or indirect (e.g. failed sewer line)	Ordinance enforcement authority (e.g. Code Enforcement Officer)	<ul style="list-style-type: none"> <li>• Issue work order</li> <li>• Schedule removal</li> <li>• Remove connection</li> <li>• Confirm removal</li> </ul>
Exempt 3 <sup>rd</sup> Party	Any	USEPA	<ul style="list-style-type: none"> <li>• Notify exempt third party and USEPA of illicit discharge</li> </ul>

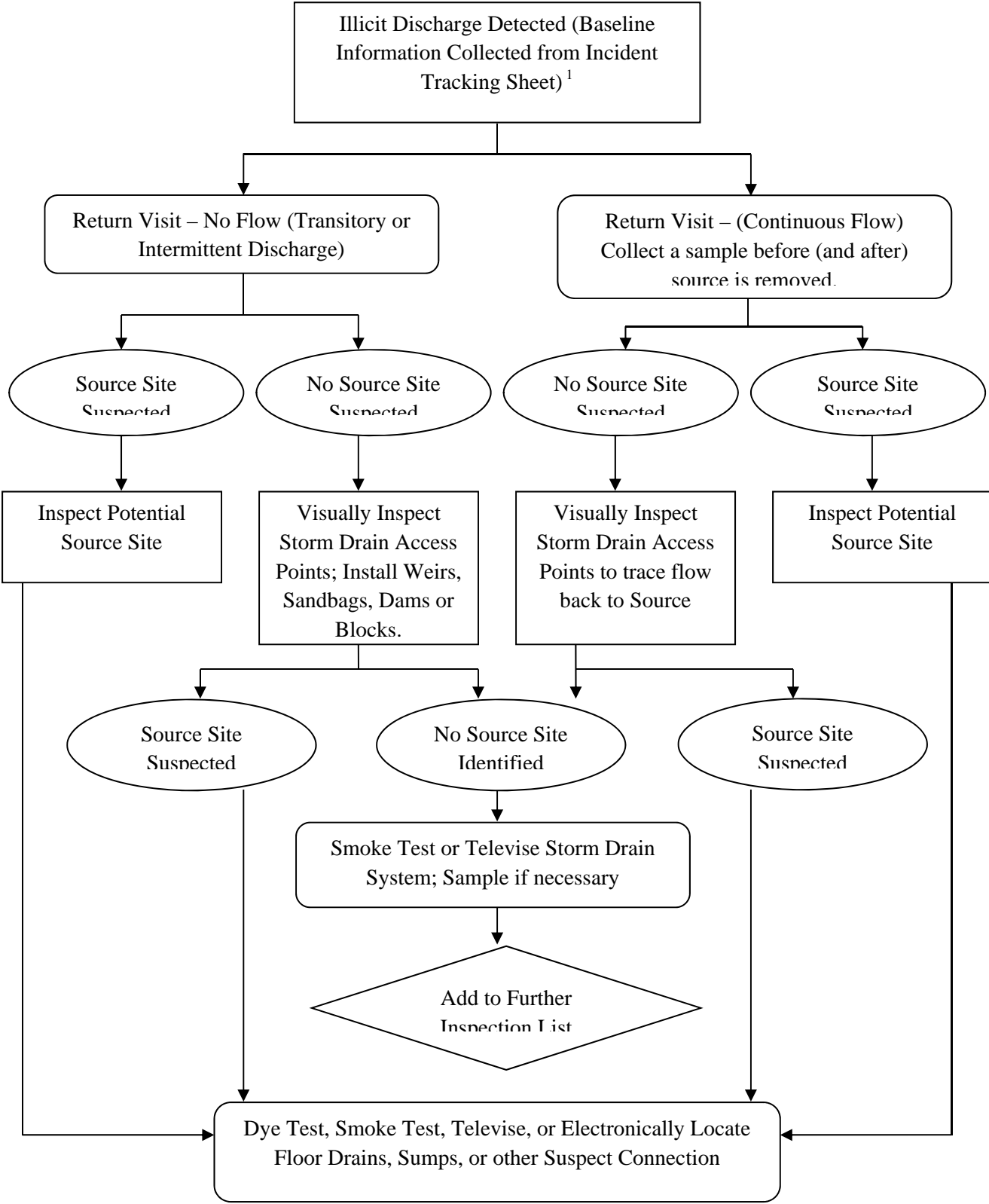

<sup>1</sup> – Guidelines and Standard Operating Procedures: Illicit Discharge Detection and Elimination and Pollution Prevention/Good Housekeeping for Stormwater Phase II Communities in New Hampshire, New Hampshire Estuary Project, 2006, p. 25, Figure 2-1.

### Illicit Discharge Incident Tracking Sheet

Incident ID:			
<b>Responder Information (for Citizen-Reported issues)</b>			
Call Taken By:		Call Date:	
Call Time:		Precipitation (inches) in past 24-48 hours:	
<b>Observer Information</b>			
Date and Time of Observation:		Observed During Regular Maintenance or Inspections? <input type="checkbox"/> Yes <input type="checkbox"/> No	
Caller Contact Information (optional) or Municipal Employee Information:			
<b>Observation Location: (complete one or more below)</b>			
Latitude and Longitude:			
Stream Address or Outfall #:			
Closest Street Address:			
Nearby Landmark:			
<b>Primary Location Description</b>		<b>Secondary Location Description:</b>	
<input type="checkbox"/> Stream Corridor (In or adjacent to stream)		<input type="checkbox"/> Outfall	<input type="checkbox"/> In-stream Flow <input type="checkbox"/> Along Banks
<input type="checkbox"/> Upland Area (Land not adjacent to stream)		<input type="checkbox"/> Near Storm Drain	<input type="checkbox"/> Near other water source (stormwater pond, wetland, ect.):
Narrative description of location:			
<b>Upland Problem Indicator Description</b>			
<input type="checkbox"/> Dumping	<input type="checkbox"/> Oil/Solvents/Chemicals	<input type="checkbox"/> Sewage	
<input type="checkbox"/> Detergent, suds, etc.	<input type="checkbox"/> Other: _____		
<b>Stream Corridor Problem Indicator Description</b>			
Odor	<input type="checkbox"/> None	<input type="checkbox"/> Sewage	<input type="checkbox"/> Rancid/Sour <input type="checkbox"/> Petroleum (gas)
	<input type="checkbox"/> Sulfide (rotten eggs); natural gas	<input type="checkbox"/> Other: Describe in "Narrative" section	
Appearance	<input type="checkbox"/> "Normal"	<input type="checkbox"/> Oil Sheen	<input type="checkbox"/> Cloudy <input type="checkbox"/> Foam
	<input type="checkbox"/> Optical enhancers	<input type="checkbox"/> Discolored	
	<input type="checkbox"/> Other: Describe in "Narrative" section		
Floatables	<input type="checkbox"/> None	<input type="checkbox"/> Sewage (toilet paper, etc)	<input type="checkbox"/> Algae <input type="checkbox"/> Trash or debris
	<input type="checkbox"/> Other: Describe in "Narrative" section		
Narrative description of problem indicators:			
Suspected Source (name, personal or vehicle description, license plate #, address, etc.):			





## **SOP 11: OIL/WATER SEPARATOR (OWS) MAINTENANCE**

Oil/water separators (OWS), also known as gas/oil separators, are structural devices intended to provide pretreatment of floor drain water from industrial and garage facilities. An OWS allows oils (and substances lighter than water) to be intercepted and be removed for disposal before entering the sanitary sewer system. Substances heavier than water settle into sludge at the bottom of the unit. The remaining water passes through the unit into the sanitary sewer system.

OWS units are generally required where petroleum-based products, wastes containing petroleum, or oily and/or flammable materials are used, produced, or stored. OWS units should not be used to manage stormwater or flow from vehicle washing facilities. High flow rates through an OWS will reduce the structure's ability to separate materials. Detergents and solvents can emulsify oil and grease, allowing the particles to enter the sewer, so these should not be disposed of in drains entering the OWS.

### *General OWS Maintenance Requirements*

1. Each OWS at a facility may receive different materials in different quantities, so the cleanout schedule may not be the same for every OWS at a facility.
2. Employees performing inspections of an OWS must be properly trained and be familiar with the maintenance of that specific structure, since function can vary based on design. Third-party firms may be utilized to perform quarterly inspections.
3. Do not drain petroleum, oil, or lubricants directly to an OWS. The structures are designed to manage these materials at low and medium concentrations in sanitary sewage, not as slug loads.
4. Do not drain antifreeze, degreasers, detergents, fuels, alcohols, solvents, coolant, or paint to the OWS.
5. Separator compartment covers should be tightly sealed to ensure floor drainage only enters the first compartment of the OWS.
6. Drains should be kept free of debris and sediment to the maximum extent practicable.
7. Spill cleanup materials should be maintained in the area served by the OWS. For more information on spill cleanup and response materials, refer to SOP 4, "Spill Response and Cleanup Procedures".

### *OWS Inspection Procedures*

Daily inspection of an OWS should include a visual examination of the area served by the OWS for evidence of spills or leaks.

Weekly inspections of an OWS should include the following:

1. Visually examine the area served by the OWS for evidence of spills or leaks.
2. Inspect the point of discharge (i.e., sewer manhole) for evidence of petroleum bypassing the OWS.
3. Inspect drains for any signs of unauthorized substances entering the OWS.
4. Examine the OWS for signs of leaks or any malfunction.

Quarterly inspections of an OWS should include the following:

1. Complete tasks noted as appropriate for daily and weekly inspection.
2. Complete the Quarterly OWS Inspection Checklist, attached, during the inspection.
3. Take the following measurements to benchmark function of the OWS:
  - A. Distance from rim of access cover to bottom of structure
  - B. Distance from rim of access cover to top of sludge layer
  - C. Depth of sludge layer ( $C = A - B$ )
  - D. Distance from rim of access cover to the oil/water interface
  - E. Distance from rim of access cover to the top of the liquid surface
  - F. Depth of oil layer ( $F = D - E$ )

### *OWS Cleaning Procedures*

Cleaning of the OWS is required when there has been a spill to the OWS that exceeds ten gallons of oil, one gallon of detergent or solvent, or any material prohibited by the owner of the sanitary sewer. Cleaning is also required when the levels of accumulated sludge and/or oil meet the manufacturer's recommended levels for cleaning. This will vary based on the manufacturer of the OWS. If the manufacturer's recommendations are unknown, the following guidelines are appropriate for determining when to clean:

1. When sludge accumulates to 25% of the wetted height of the separator compartment; or
2. When oil accumulates to 5% of the wetted height of the separator compartment; or
3. When 75% of the retention capacity of the OWS is filled.

Cleaning should be performed a minimum of once per year. When cleaning is required, it shall be performed by licensed OWS maintenance companies. Materials removed from the OWS must be disposed of in accordance with Massachusetts Hazardous Waste Regulations, 310 CMR 30.00.

### *Documentation of Cleaning and Service*

The operator of the premises where the OWS is located shall maintain a log describing the date and type of all inspections, service and maintenance performed in connection with the Separator. Documentation shall include the identity of the inspector (or the identity of the person or entity that performed the service and/or maintenance). Records shall also document the amount of residue removed from the OWS each time it was cleaned, and how removed materials were disposed. This documentation shall be maintained for a minimum of six years.

### *Attachments*

1. Quarterly OWS Inspection Checklist

### *Related Standard Operating Procedures*

1. SOP 4, Spill Response and Cleanup Procedures

**OIL/WATER SEPARATOR (OWS)  
QUARTERLY INSPECTION CHECKLIST**

Facility: \_\_\_\_\_

OWS Location: \_\_\_\_\_

Inspected By: \_\_\_\_\_

Date: \_\_\_\_\_

Visual Inspection	Are there any signs of spills or leaks in the general area?	Yes <input type="checkbox"/>	No <input type="checkbox"/>
	Is there any evidence of petroleum bypassing the OWS?	Yes <input type="checkbox"/>	No <input type="checkbox"/>
	Are there any unauthorized substances entering the OWS?	Yes <input type="checkbox"/>	No <input type="checkbox"/>
	Does the OWS exhibit any signs of leaks or malfunctions?	Yes <input type="checkbox"/>	No <input type="checkbox"/>

If you answered “Yes” to any of the above questions, further inspection, repair, and/or cleaning may be necessary.

Measurements	A	Distance from rim of access cover to bottom of structure	
	B	Distance from rim of access cover to top of sludge layer	
	C = A - B	Depth of sludge layer	
	D	Distance from rim of access cover to the oil/water interface	
	E	Distance from rim of access cover to the top of the liquid surface	
	F = D - E	Depth of oil layer	

If the values for “C” and/or “F” are greater than those in the manufacturer’s recommendations, the OWS must be cleaned by a licensed OWS maintenance company.

# SOP 12: Storage and Use of Pesticides and Fertilizer

## Introduction

The use and improper storage of pesticides, herbicides, and fertilizers can contribute to the discharge of nutrients and toxic compounds to the municipal storm drainage system and surface waters. The goal of this Standard Operating Procedure (SOP) is to provide guidance on municipal employees on proper handling and storage of pesticides, herbicides, and fertilizers to prevent the discharge of pollutants from the MS4.

## Procedures

Below are procedures for the storage and use of fertilizers, pesticides, and herbicides by municipal employees. In this section, the term “pesticide” include products used as herbicides. Refer to SOP 4: Spill Response and Cleanup and SOP 17: Hazardous Materials Storage and Handling for information on and handling spills and hazardous materials.

### *Storage*

- Store pesticides and fertilizers in high, dry locations in accordance with the manufacturer’s specifications.
- Store in cool, well-ventilated, and insulated areas to protect against temperature extremes.
- Store in areas that have been constructed in accordance with local fire codes for storing flammable or combustible materials.
  - Flammable products should be stored separately from non-flammable products, preferably in a fire-proof cabinet.
  - Small quantities (less than 500 lbs. or 220 gallons) of pesticides can be stored in cabinets constructed of double-walled 18-gauge sheet metal.
  - Large quantities (greater than 500 lbs. or 220 gallons) of pesticides can be stored in a prefabricated Hazardous Material Storage building or in a purpose-built storage facility. It is not anticipated that many municipal facilities will store quantities in excess of 500 lbs. or 220 gallons of pesticides.
  - Building walls should have a two-hour fire rating and be impervious to the stored materials.
  - Floors should be watertight, impervious, and provide spill containment.
- Store materials in an enclosed area or in covered, impervious containment, such as a locked cabinet. The cabinet should be located in a first story room or one that has direct access to the outdoors. Storage areas should be equipped with easily accessible spill cleanup materials and portable firefighting equipment. Regularly inspect storage areas for leaks and spills. Emergency eyewash stations and emergency drench showers should be located near the storage area.
- For pesticides, storage cabinets should be kept locked and the door to the storage area should contain a weather proof sign that warns of the existence and danger of the pesticides inside. The door should be kept locked. The sign should be visible at a distance of 25 feet and should read as follows:

**DANGER**  
**PESTICIDE STORAGE AREA**  
**ALL UNAUTHORIZED PERSONS KEEP OUT**  
**KEEP DOORS LOCKED WHEN NOT IN USE**

The sign should be posted in both English and any other language used by maintenance workers.

- Pesticides should not be stored in the same place as ammonium nitrate fertilizer.
- Separate pesticides and fertilizers from other chemical storage and other flammable materials.
- Label all containers with date of purchase. Clearly label all secondary containers. Use older materials first.
- Order for delivery as close to the time of use as possible to reduce the amount of chemicals stored at the facility.
- Order only the amount of materials needed in order to minimize excess or obsolete materials, which require storage and disposal.
- Never leave unlabeled or unstable pesticides and fertilizers in uncontrolled locations.
- Maintain a current written inventory of all pesticides and fertilizers at the storage site.
- Ensure that contaminated waste materials are kept in designated containers and stored in labeled, designated, covered, and contained areas.
- Dispose of excess or obsolete pesticides/fertilizers and associated waste materials in accordance with the manufacturer's specification and all applicable regulations.

***Use and Application of Fertilizers***

- All fertilizer products manufactured or distributed in the State of Massachusetts must be registered with the Department of Agricultural Resources.
- Perform soil testing before choosing a fertilizer. The quantity of available nutrients already present in the soil will determine the type and amount of fertilizer that is recommended. The soil test will also determine the soil pH, humic matter, texture, and exchangeable acidity, which will indicate whether pH adjustment is required for fertilizer to work efficiently. A soil test should be completed at each facility, as soil type can vary widely within a single community.
  - Soil tests are recommended every 3-4 years for turf and plantings (more frequently for problem or newly planted areas) and every year for soil where phosphorus-containing fertilizers are used. Soil pH tests should be conducted every year for all sites.
  - When collecting soil samples, take multiple samples for each target area at a four-inch depth; mix the samples together in a container and properly label the sample with property information and site use type. Separately sample areas that have discoloration, abnormal plant growth, or other problems. Take the sample at approximately the same time every year. If the area has been fertilized, wait eight weeks after fertilizing to test the soil to ensure nutrients have been absorbed.
- When selecting the optimal type of fertilizer to use on an area, consider the soil test results, type of turf, and type of turf use. Slow-use fertilizer should be used for turf grass.
- Calibrate application equipment regularly to ensure proper application and loading rates.

- Mix fertilizers using clean application equipment under cover in an area where accidental spills will not enter surface water or groundwater and will not contaminate the soil.
- Fertilizers should only be applied by properly trained personnel.
- Never apply fertilizers in quantities exceeding the manufacturer's instructions. Instead, apply small amounts throughout the growing season.
- Time fertilizer application methods for maximum plant uptake, usually in the fall and spring (e.g., between April 15 and October 15). When applying at the beginning and end of planting season, take into consideration the slower uptake rate of fertilizer by plants and adjust the fertilizer application accordingly.
- Never apply fertilizer during a drought, when the soil is dry or frozen, when it is raining, or immediately before expected rain.
- Fertilizer should be applied when the ground temperature is above 55° F.
- Apply fertilizers in amounts appropriate for the type of vegetation to minimize losses to surface water and groundwater. Use the results of the soil test to determine optimal fertilizer timing and application rates.
- Where applicable, till fertilizers into the soil rather than dumping or broadcasting (proper application techniques will depend on the type of soil and vegetation).
- Do not hose down paved areas after fertilizer application if drainage will enter into an engineered storm drain system or drainage ditch.
- Limit irrigation after fertilizer application to prevent runoff (approximately ½ inch of water per application for a week following application).
- Turn off irrigation systems during periods of adequate rainfall.
- Do not over-apply fertilizer in late fall to “use it up” before winter. The effectiveness of fertilizer does not reduce when stored.
- If phosphorus fertilizer is used when re-seeding, mix the phosphorus into the root zone. Do not apply directly to the soil surface.
- Avoid combined products such as “weed and feed,” which do not target specific problems at the appropriate time.

### ***Use and Application of Pesticides and Herbicides***

The State of Massachusetts has a stringent program for registration of pesticides and certification of those authorized to apply them. Once a pesticide has been approved for use by the USEPA, it must be registered by the Massachusetts Pesticide Board Subcommittee prior to being distributed, purchased, or used in Massachusetts. Pesticide classification in Massachusetts is based on the potential adverse effects the pesticide may have on humans or the environment. “Restricted Use” pesticides can only be sold by Licensed Dealers to Certified Applicators, while “State Limited Use” pesticides may be restricted to use by certain individuals or require written permission from the Department of Agricultural Resources prior to use. Legal application of pesticides must be performed by an individual licensed or certified by the Massachusetts Department of Agricultural Resources. A Commercial Applicator License is required for applying general use pesticides, and a Commercial Applicator Certification is required for applying restricted and state limited use products.

### ***Use and Application of Pesticides***

- Pesticides should only be applied by licensed or certified applicators.

- Calibrate application equipment regularly to ensure proper application and loading rates.
- Ensure that pesticide application equipment is capable of immediate shutoff in case of emergency.
- Conduct spray applications according to specific label directions and applicable local regulations.
- Never apply pesticides in quantities exceeding the manufacturer's instructions.
- Apply pesticides at the life stage when the pest is most vulnerable.
- Never apply pesticides if it is raining or immediately before expected rain.
- Establish setback distances from pavement, storm drains, and waterbodies, which act as buffers from pesticide application, with disease-resistant plants and minimal mowing.
- Do not apply pesticides within 100 feet of open waters or of drainage channels.
- Spot treat infected areas instead of the entire location.
- Mix pesticides and clean application equipment under cover in an area where accidental spills will not enter surface water or groundwater and will not contaminate soil.
- Do not hose down paved areas after pesticide application to a storm drain or drainage ditch.
- Recycle rinsate from equipment cleaning back into product.
- Choose the least toxic pesticide that is still capable of reducing the infestation to acceptable levels.
- Use alternatives to pesticides, such as manual weed control, biological controls, and Integrated Pest Management strategies (learn more at: <https://www.mass.gov/files/documents/2016/08/wk/ipm-kit-for-bldg-mgrs.pdf>).
- For the use of herbicides, reduce seed release of weeds by timing cutting and pesticide application at seed set. Select vegetation and landscaping that is low-maintenance in order to tolerate low levels of weeds without interfering with aesthetics.

### Employee Training

- Employees who handle pesticides, fertilizers, and herbicides are trained ##NUMBER times per year on proper handling and storage procedures.
- Employees are also trained on stormwater pollution prevention, illicit discharge detection and elimination (IDDE) procedures, and spill and response procedures.
- If services are contracted, the contractor should be given a copy of this and any applicable SOPs to ensure compliance with MS4 regulations.

### Related Standard Operating Procedures

- SOP 4: Spill Response and Cleanup
- SOP 17: Hazardous Materials Storage and Handling

## SOP 13: WATER QUALITY SCREENING IN THE FIELD

### *Introduction*

Outfalls from an engineered storm drain system can be in the form of pipes or ditches. Under current and pending regulations, it is important to inspect and document water quality within the MS4 system under both dry weather and wet weather conditions. SOP 1, “Dry Weather Outfall Inspection” and SOP 2, “Wet Weather Outfall Inspection”, cover the objectives of these activities and how water quality parameters can be collected during both types of inspections. SOP 3, “Catch Basin Inspection and Cleaning”, describes how this operations and maintenance activity can serve as an additional opportunity to collect water quality data.

SOP 2 included detailed information on how to collect discrete analytical samples to be processed by a laboratory. In contrast, this SOP addresses screening-level measurements than can be collected at outfalls, catch basins, receiving waters, or other water bodies. The measurements can be collected with field test kits or with portable meters.

Water quality screening data collected in this manner can feed into an illicit discharge detection and elimination investigation, like the process described in SOP 10, “Locating Illicit Discharges”.

### *Visual Condition Assessment*

SOP 1, SOP 2, and SOP 3 describe a Visual Condition Assessment to collect observations related to the quality of stormwater conveyed by an engineered storm drain system. These observations may include such visual evidence and/or potential pollutants as:

- Foaming (detergents)
- Discoloration
- Evidence of sanitary waste
- Optical enhancers (fluorescent dyes added to laundry detergent); and
- Turbidity

If a Visual Condition Assessment indicates the presence of these pollutants, it may be necessary to quantify the extent of each, and gather data on other parameters that cannot be visually observed but can be measured using field kits or meters. These parameters include:

- Ammonia
- Chloride (present in treated drinking water but not groundwater)
- Conductivity
- Fluoride
- Hardness
- pH
- Potassium



*Field Kits and Sampling Methods Available*

In recent drafts of new MS4 Permits, U.S. EPA Region 1 has identified several test kits that are acceptable for use in the field, and other regulatory agencies have also completed similar reviews. The following table shows field test kits and portable meters that can be used for screening parameters.

**Table SOP 13-1  
Field Measurements, Test Kits, and Instrumentation**

Analyte or Parameter	Instrumentation (Portable meter)	Field Test Kit
Ammonia	CHEMetrics™ V-2000 Colorimeter Hach™ DR/890 Colorimeter Hach™ Pocket Colorimeter™ II	CHEMetrics™ K-1410 CHEMetrics™ K-1510 (series) Hach™ NI-SA Hach™ Ammonia Test Strips
Bacteria	Bacteria field test kits require 24-hour window	
Boron	N/A	Hanna™ HI 38074 Taylor™ K-1541
Chloride	CHEMetrics™ V-2000 Colorimeter Hach™ Pocket Colorimeter™ II LaMotte™ DC1200 Colorimeter	CHEMetrics™ K-2002 through K-2070 Hach™ CDS-DT Hach™ Chloride QuanTab® Test Strips
Color		Hach™ ColorDisc
Conductivity	CHEMetrics™ I-1200	N/A
Detergents (Surfactants)	CHEMetrics™ I-2017	CHEMetrics™ K-9400 and K-9404 Hach™ DE-2
Fluoride	CHEMetrics™ V-2000 Colorimeter Hach™ Pocket Colorimeter™ II	N/A
Hardness	N/A	CHEMetrics™ K-1705 and K-1710 CHEMetrics™ K-4502 through K-4530 Hach™ HA-DT Hach™ Hardness Test Strips
Optical enhancers	Field tests still under development	
pH	CHEMetrics™ I-1000	Hach™ 17J through 17N Hach™ pH Test Strips
Potassium	Horiba™ Cardy C-131	LaMotte™ 3138 KIW
Turbidity	CHEMetrics™ I-1300	N/A

Each field test kit will include instructions specific to that test kit, and most kits are available in configurations that detect different ranges of the parameter. For example, the CHEMetrics™ detergents kit K-9400 shown above detects concentrations of 0 to 3 milligrams per liter (mg/L) while the K-9404 kit detects concentrations of 0 to 1,400 mg/L.

The table below shows values identified by the U.S. EPA and the Center for Watershed Protection as typical screening values for select parameters. These represent the typical concentration (or value) of each parameter expected to be found in stormwater. Screening values that exceed these benchmarks may be indicative of pollution and/or illicit discharges.

**Table SOP 13-2**  
**Benchmark Field Measurements for Select Parameters**

Analyte or Parameter	Benchmark
Ammonia	>50.0 mg/L
Conductivity	>2,000
Detergents (Surfactants)	> 0.25 mg/L
Fluoride	>0.25 mg/L
pH	<5
Potassium	>20 mg/L

If and when water quality screening samples, whether using field test kits or portable meters, exceed these benchmark concentrations, the inspector should consider collecting analytical samples for laboratory analysis.

#### *Advantages and Disadvantages of Field Testing*

Field test kits can be convenient for use as a screening tool, initial purchase costs are low (typically \$0.50 to \$5.00 for the kits included in Table SOP 13-1), and the costs are far less than full analyses at a laboratory. However, some disadvantages of this screening method include:

- Limited shelf life
- Labor cost associated with inspector's time
- Generation of wastes, including glass vials and used reagent
- Steps and processes for each kit can vary widely, resulting in errors
- Trained staff are required in order to effectively utilize kits
- Not all kits are accepted by all regulatory agencies
- Limited useful detection range

Portable instrumentation such as the colorimeters shown in Table SOP 13-1 have the benefit of providing accurate readings, measure to low detection limits, and can be purchased pre-programmed to measure concentrations of most parameters required. Disadvantages of portable instrumentation include:

- High initial purchase cost
- Requirement for ongoing calibration and maintenance
- Individual probes require periodic replacement
- Specific storage requirements to maintain calibration
- Trained staff are required in order to effectively utilize meters

*Related Standard Operating Procedures*

1. SOP 1, Dry Weather Outfall Inspection
2. SOP 2, Wet Weather Outfall Inspection
3. SOP 3, Catch Basin Cleaning and Inspection
4. SOP 10, Locating Illicit Discharges

**WATER QUALITY SCREENING FORM**

Outfall I.D.			
Outfall Location			
Inspector's Name			
Date of Inspection		Date of Last Inspection	
Start Time		End Time	
Type of Inspection:	Regular <input type="checkbox"/>	Pre-Storm Event <input type="checkbox"/>	During Storm Event <input type="checkbox"/> Post-Storm Event <input type="checkbox"/>
Most Recent Storm Event			

**FIELD WATER QUALITY SCREENING RESULTS**

Sample Parameter	Field Test Kit or Portable Instrument Meter	Benchmark	Field Screening Result	Full Analytical Required?
Ammonia <sup>1</sup>		> 50.0 mg/L		<input type="checkbox"/> Yes <input type="checkbox"/> No
Boron <sup>1</sup>		> 0.35 mg/L		<input type="checkbox"/> Yes <input type="checkbox"/> No
Chloride <sup>2</sup>		230 mg/L		<input type="checkbox"/> Yes <input type="checkbox"/> No
Color <sup>1</sup>		> 500 units		<input type="checkbox"/> Yes <input type="checkbox"/> No
Specific Conductance <sup>1</sup>		> 2,000 µS/cm		<input type="checkbox"/> Yes <input type="checkbox"/> No
Detergents & Surfactants <sup>3</sup>		> 0.25 mg/L		<input type="checkbox"/> Yes <input type="checkbox"/> No
Fluoride <sup>3</sup>		> 0.25 mg/L		<input type="checkbox"/> Yes <input type="checkbox"/> No
Hardness <sup>1</sup>		< 10 mg/L or > 2,000 mg/L		<input type="checkbox"/> Yes <input type="checkbox"/> No
pH <sup>1</sup>		< 5		<input type="checkbox"/> Yes <input type="checkbox"/> No
Potassium <sup>1</sup>		> 20 mg/L		<input type="checkbox"/> Yes <input type="checkbox"/> No
Turbidity <sup>1</sup>		> 1,000 NTU		<input type="checkbox"/> Yes <input type="checkbox"/> No

<sup>1</sup> – *Illicit Discharge Detection and Elimination: A Guidance Manual for Program Development and Technical Assessments*, Center for Watershed Protection and Robert Pitt of University of Alabama, 2004, p. 134, Table 45.

<sup>2</sup> – *Env-Ws 1703.21 Water Quality Criteria for Toxic Substances*, State of New Hampshire Department Surface Water Quality Regulations.

<sup>3</sup> – *Appendix I – Field Measurements, Benchmarks and Instrumentation*, Draft Massachusetts North Coastal Small MS4 General Permit, 2009.

**FULL ANALYTICAL TESTING WATER QUALITY RESULTS**

<b>Sample Parameter</b>	<b>Analytical Test Method</b>	<b>Sample Collection (Time/Date)</b>	<b>Testing Lab</b>	<b>Analytical Testing Result</b>
Ammonia	EPA 350.2/SM4500-NH3C			
Bacteria	E coli: 1103.1; 1603 Enterococcus: 1106.1; 1600			
Boron	EPA 212.3			
Chloride	EPA 9251			
Color	EPA 110.2			
Specific Conductance	SM 2510B			
Detergents & Surfactants	EPA 425.1/SM5540C			
Fluoride	EPA 300.0			
Hardness	EPA 130.1/SM 2340B			
Optical Enhancers	N/A*			
pH	EPA 150.1/SM 4500H			
Potassium	EPA 200.7			
Turbidity	SM 2130B			

\*- There is presently no USEPA Standard Method for analysis of optical enhancers. Typically, sample pads are described as with "Present" or "Not Present" for fluorescing dye when exposed to UV light or a fluorometer.

## SOP 15: PRIVATE DRAINAGE CONNECTIONS

### *Introduction*

The 2003 Massachusetts MS4 Permit described a number of non-stormwater discharges to the engineered storm drain system that are considered “allowable”, as long as an individual community has not prohibited the discharge. Allowable non-stormwater discharges to the storm drain system can include the following, per Page 8 of the 2003 Massachusetts MS4 Permit (not inclusive):

- Diverted stream flows;
- Uncontaminated groundwater infiltration (as defined at 40 CFR 35.2005(20));
- Uncontaminated pumped groundwater;
- Foundation drains;
- Water from crawl space pumps;
- Footing drains; and
- Flows from riparian habitats and wetlands.

The municipalities regulated under the 2003 Massachusetts MS4 Permit have approved connection of the above sources to engineered storm drain systems in a variety of ways, ranging from full acceptance to full prohibition of discharges from these sources.

This Standard Operating Procedure intends to provide guidance to the municipalities on how to evaluate non-stormwater discharges to the engineered storm drain system from private connections such as foundation drains (also referred to as perimeter drains), footing drains (similar to foundation drains), non-pumped groundwater infiltration, and other private non-stormwater discharges. Discharges from sump pumps or other pumped groundwater sources are being addressed by a separate Sump Pump Discharge Policy, and are not covered by this Standard Operating Procedure.

### *Applicability of Private Drainage Connections*

Connections of private drainage to the municipal storm drain system generate two primary concerns. The first concern is the potential for pollution from the connection, such as if subsurface contamination or septic system waste is conveyed via drainage from a foundation drain to the stormwater outfall. The second concern is that system capacity can be reduced because of pipe space occupied by flow from private sources. This results in a decreased capacity for the system to convey stormwater during wet weather events, increasing pipe surcharging and the potential for localized street flooding.

For both of these reasons, this SOP is not intended to encourage connections of private drainage to the engineered storm drain system. Instead, this SOP is to be used as guidance for connecting private drainage in scenarios where property damage may result, where discharge of water to the ground surface would result in a public hazard or nuisance, and where there is no other reasonable alternative for discharge of stormwater from the private property.

The connection of private drainage cannot be used for the discharge of non-stormwater from the site.

*Requirements for Connection of Private Drainage*

A community may consider connection of private drainage to the engineered storm drain system if all of the following conditions are met.

1. The owner of the private drainage (hereafter referred to as the applicant) accepts responsibility for securing all other permits or approvals for the completion of the work, including any right-of-way process required by the municipality.
2. The applicant agrees to submit plans for review by the municipality, showing the location of all proposed work.
3. The applicant agrees to pay for all costs associated with the completion of the work, including but not limited to the costs of land survey, legal reviews, testing, permitting, construction, engineering design, and traffic control.
4. The applicant agrees to compensate the municipality for the time of its Town Engineer, Code Enforcement Officer, water department (or quasi-municipal water district), consulting engineer, and/or other official, as required, for their review of the proposed connection plans.
5. The applicant agrees to perform flow metering to determine the volume of discharge that would enter the municipal system from the property.
6. The applicant agrees to have dye and/or smoke testing performed to confirm that no prohibited fixtures would be connected to the municipal system from the property (i.e., to document that the connection would not represent an illicit discharge).
7. The applicant agrees to use the same materials specified by the municipality for construction of the system, and provide a materials list to the municipality for review and approval in advance of construction. If any pump is to be utilized to convey the drainage, cut sheets on the selected pump shall be provided to the municipality for review and approval in advance of construction.
8. The applicant's contractor agrees to secure all road opening permits, drainlayer permits, and other construction permits as required by the municipality.
9. The applicant's discharge is in close proximity to the municipal system, for example, within 300 linear feet, and the connection to the municipal system can be completed without impacting other private property or municipal infrastructure and without significant impact to aboveground assets. Aboveground assets may include trees, fences, stone walls, utility poles, gardens, signs, or other semi-permanent features.
10. The applicant agrees to execute a covenant for the property to reflect the drainage connection, and record this covenant with the Registry of Deeds for the property.
11. The applicant agrees to install a backflow preventer, cleanout, and a shutoff device in such places that all fittings are accessible to the municipality.
12. The applicant agrees to install an oil/water separator, if required by the municipality, and provide documentation of maintenance of this device.
13. The applicant agrees to complete confirmation analytical testing of the discharge, with pollutants and laboratory specified by the municipality. This testing may occur during the initial evaluation phase, and may be required annually or on some other frequency to demonstrate ongoing compliance.

14. The applicant agrees to provide record drawings to the municipality documenting the location of the discharge, with ties to permanent structures.
15. The applicant agrees to pay any annual review or inspection fees associated with the discharge.

#### *Right of Refusal for New Connections of Private Drainage*

The municipality shall reserve the right to refuse connection of the private drainage to the engineered storm drain system if any of the following can be demonstrated:

1. The municipal system does not have adequate capacity to manage proposed flow from the connection.
2. The private drainage includes flow from municipal users or sources.
3. The stormwater outfall that manages flow from the applicant's property discharges to a water body identified as impaired in the most current version of the Integrated List of Waters (i.e., the 303(d) list) or is subject to stringent local controls.
4. The connection would be located within 100 linear feet of a subsurface wastewater disposal system (i.e., septic system).
5. The connection would be located within a public drinking water supply Zone I.
6. The connection would be located within a public drinking water supply Zone II, and the municipality's water department (or quasi-municipal water district) has not approved of the connection in writing.
7. Flow conveyed by the discharge would create a safety hazard such as ponding or freezing to vehicular, pedestrian, bicycle or other transportation, or would create erosion or the potential for erosion.
8. The connection jeopardizes public health, safety, or natural resources.
9. The the connection fails to meet the terms and conditions of this SOP.

#### *Existing Connections of Private Drainage*

Existing private connections are considered to be a grandfathered, as long as they are used only for discharge of non-stormwater discharges allowed by the 2003 Massachusetts MS4 Permit. Any modification made to any grandfathered connection shall be subject to the conditions in this SOP.

The municipality may revoke grandfathered approval if the municipality determines that any of the nine conditions under "Right of Refusal for New Connections of Private Drainage" become applicable.



## SUMP PUMP INSPECTION

Discharge from sump pumps is not always an allowable non-stormwater discharge. As such, the practice of connecting sump pumps to the engineered storm drain system was not fully addressed by the 2003 Massachusetts MS4 Permit. It is therefore up to the discretion of the municipality to determine whether or not a building owner should be permitted to connect a sump pump to the engineered storm drain system.

All sump pumps that have been approved via permit process to tie into the engineered storm drain system should be inspected annually. The inspector has the right to enter and inspect the premises where the sump pump is located, including any tanks, storage areas, or rooms that may discharge or be caused to discharge to the sump pump. The inspector also has the right to sample or monitor any substances or parameters at any location for purposes of assuring compliance with the Sump Pump Drainage Connection Agreement or as otherwise authorized by the Clean Water Act. In addition, the inspector has the right to have access to and copy any records required to be kept under the terms and conditions of the Agreement.

This form shall be used by the inspector to ensure that the sump pump remains in compliance with the current policy.

### General Information

Address of Connection			
Make/Model			
Inspector's Name			
Date of Inspection		Date of Last Inspection	
Start Time		End Time	

### Compliance Review

Each of the following conditions should be evaluated as "True" during the on-site inspection to demonstrate compliance. If any of the following conditions, as recorded during the inspection, are not satisfied (i.e., if the evaluation is "False"), the sump pump shall be considered to be in violation of the original connection Agreement.

#### *Prior to the Inspection*

The inspector shall review the following questions prior to completing the on-site inspection.

Condition	Evaluation	Comment
A covenant for the property to reflect the drainage connection has been recorded at the Registry of Deeds	True <input type="checkbox"/> False <input type="checkbox"/>	
Record drawings documenting the location of the discharge were supplied to the municipality after construction.	True <input type="checkbox"/> False <input type="checkbox"/>	
<b>If property has an oil/water separator:</b> evidence of annual maintenance of oil/water separator was provided to municipality in previous period	True <input type="checkbox"/> False <input type="checkbox"/>	
<b>If property was required to complete analytical monitoring:</b> results of analytical testing of discharge provided to municipality in previous period.	True <input type="checkbox"/> False <input type="checkbox"/>	
Other:		

*During the On-Site Inspection*

The inspector shall make the following observations during the on-site inspection, and note the results in the table.

Condition	Evaluation	Comment
Sump pump is used for the discharge of stormwater only	True <input type="checkbox"/> False <input type="checkbox"/>	
The discharge, and liquid in the sump, is visibly free of oil or other pollutants.	True <input type="checkbox"/> False <input type="checkbox"/>	
Grey water/black water is not visibly present in the discharge	True <input type="checkbox"/> False <input type="checkbox"/>	
Sediment-laden surface water is not visibly present in the discharge	True <input type="checkbox"/> False <input type="checkbox"/>	
Flow from the connection does not exceed approved flow	True <input type="checkbox"/> False <input type="checkbox"/>	
No prohibited fixtures are connected to the municipal system from the property	True <input type="checkbox"/> False <input type="checkbox"/>	
The pump presently utilized is the same as the pump approved by the municipality.	True <input type="checkbox"/> False <input type="checkbox"/>	

(continued)

Condition	Evaluation	Comment
The pump presently utilized is the same as the pump approved by the municipality.	True <input type="checkbox"/> False <input type="checkbox"/>	
Backflow preventer, cleanout, and shutoff device remain operational and easily accessible to municipality	True <input type="checkbox"/> False <input type="checkbox"/>	
Other:		

**Review of Compliance with Sump Pump Policy**

If any of the following conditions is applicable, as recorded during the inspection, the municipality shall have the right to revoke approval of the sump pump, including grandfathered sump pumps.

<input type="checkbox"/>	There is inadequate capacity of the drainage system to manage flow from the connection.
<input type="checkbox"/>	Private drainage includes flow from industrial users or sources.
<input type="checkbox"/>	Private drainage includes flow from multiple users, systems, or sources.
<input type="checkbox"/>	The connection is located within 100 linear feet of a subsurface wastewater disposal system, such as a septic system.
<input type="checkbox"/>	The stormwater outfall managing the property flow discharges to a water body identified as impaired in the most current of the Integrated List of Waters (303(d) list) or is subject to stringent local controls.
<input type="checkbox"/>	The connection is located within a public drinking water Zone I.
<input type="checkbox"/>	The connection is located in a public drinking water supply Zone II, and the water department or district has not approved of the connection in writing.
<input type="checkbox"/>	Flow conveyed to the discharge creates a safety hazard such as ponding or freezing to vehicular, pedestrian, bicycle, or other transportation, or creates erosion or the potential for erosion.
<input type="checkbox"/>	The connection jeopardizes public health, safety, or natural resources.
<input type="checkbox"/>	The connection fails to meet the terms and conditions of the Agreement.

**Non-Compliance Actions**

The municipality shall provide the property owner with written notice of the violation with corrective action to be taken. The property owner shall have thirty days from the receipt of the notice to commence curative action of the violation.

# SOP 16: Streets and Parking Lots

## Introduction

Regular sweeping of streets and municipally-owned parking lots is important for maintaining clean and safe roadways. It also plays a vital role in keeping pollutants like sand, trash, and leaves out of the MS4. The goal of this written Standard Operating Procedure (SOP) is to provide guidance to municipal employees on street and parking lot sweeping procedures and frequencies to reduce the discharge of pollutants to the storm drainage system and receiving waters. If sweeping services are contracted, this SOP should be provided to the contractor. The contract should specify that the contractor is responsible for compliance with all applicable laws.

## Procedures

The Town of Foxborough will implement the following street and parking lot sweeping procedures to reduce the discharge of pollutants from the MS4:

### Sweeping Frequency

- Due to the impairments of its surface waters, the Town of Foxborough has elected to have all streets swept and/or cleaned a minimum of twice per year, once in the spring (following winter activities such as sanding) and at least once in the fall (Sept. 1 – Dec. 1; following leaf fall).
- Sweep as soon as possible after snow melt and following winter activities such as sanding to capture sand and debris before it is washed into the storm drainage system.
- Consider more frequent sweeping for targeted areas based on pollutant load reduction potential, inspections, pollutant loads, catch basin cleaning or inspection results, land use, impaired waters, or other factors.
- For rural uncurbed roadways with no catch basins and limited access highways, the Town of Foxborough will either meet the minimum frequencies above, or develop and implement an inspection, documentation, and targeted sweeping plan outlining reduced frequencies within two (2) years of the effective date of the MS4 Permit, and submit such plan with its year one annual report.
- The Town of Foxborough's annual report will include the sweeping schedule developed above to target areas with high pollutant loads.

### Sweeping Practices

- Street sweeping should be conducted in dry weather. Sweeping should not be conducted during or immediately after rain storms.
- Dry cleaning methods should be used whenever possible, with the exception of very fine water spray for dust control. Avoid wet cleaning or flushing of the pavement.
- When necessary, enact parking bans to facilitate sweeping on busy streets.
- Sweep in a manner that avoids depositing debris into storm drains.
- Sweeping equipment (mechanical, regenerative air, vacuum filter, tandem sweeping) should be selected depending on the level of debris. Brush alignment, sweeper speed, rotation rate, and sweeping pattern should be set to optimal levels to manage debris.
- Routinely inspect and perform maintenance on sweeping equipment to reduce the potential for leaks. See SOP 21: Operations and Maintenance of Municipal Vehicles and Equipment for more information.

### **Sweepings Reuse and Disposal**

- The reuse of sweepings is recommended by MassDEP. If street sweepings are reused (e.g., as anti-skid material or fill in parking lots), they should be properly filtered to remove solid waste, such as paper or trash, in accordance with their intended reuse. All reuse and/or disposal of street sweepings will be managed in accordance with current MassDEP policies and regulations.
- Sweepings intended for reuse can be stored for up to one year in approved temporary storage areas. Storage areas should be protected to prevent erosion and runoff and should be located away from wetland resource areas and buffer zones, surface water, or groundwater.
- Sweepings are classified as solid waste. If not reused, they should be disposed of at solid waste disposal sites.
- For additional information on approved reuses of sweepings and storage/disposal policies, refer to MassDEP policy #BAW-18-001: Reuse and Disposal of Street Sweeping (<https://www.mass.gov/files/documents/2018/05/14/street-sweepings.pdf>).
- The Town of Foxborough will use storage area behind the Landfill for temporary storage of sweepings. Street sweepings will ultimately be disposed of at the Compost Facility.

### **Documentation and Reporting**

The following information should be documented and included in each annual report:

- Number of miles cleaned or the volume or mass of material removed (refer to the sweeping log in the attachments).

### **Employee Training**

- Employees who perform street and parking lot sweeping are trained once per year on these procedures and the proper operation of related equipment.
- Employees are also trained on stormwater pollution prevention, illicit discharge detection and elimination (IDDE) procedures, and spill and response procedures.
- If services are contracted, the contractor should be given a copy of this and any applicable SOPs to ensure compliance with MS4 regulations.

### **Attachments**

1. Street and Parking Lot Sweeping Log

### **Related Standard Operating Procedures**

1. SOP 21: Operations and Maintenance of Municipal Vehicles and Equipment



Commonwealth of Massachusetts  
Executive Office of Energy & Environmental Affairs

# Department of Environmental Protection

One Winter Street Boston, MA 02108 • 617-292-5500

Charles D. Baker  
Governor

Karyn E. Polito  
Lieutenant Governor

Matthew A. Beaton  
Secretary

Martin Suuberg  
Commissioner

**REUSE AND DISPOSAL OF STREET SWEEPINGS**

**DEPARTMENT OF ENVIRONMENTAL PROTECTION**

**POLICY # BAW-18-001**

**(SUPERSEDES POLICY # BWP-94-092)**

This Policy provides guidance to the regulated community about the Department of Environmental Protection's requirements, standards, and approvals for handling reuse or disposal of street sweepings. This Policy supersedes Department Policy BWP-94-092.

5/14/18

Date

Christine Kirby  
Assistant Commissioner

This information is available in alternate format. Contact Michelle Waters-Ekanem, Director of Diversity/Civil Rights at 617-292-5751.  
TTY# MassRelay Service 1-800-439-2370

MassDEP Website: [www.mass.gov/dep](http://www.mass.gov/dep)

Printed on Recycled Paper

**POLICY #BAW-18-001  
TABLE OF CONTENTS**

	<b>Page</b>
<b>1. Policy Statement and Scope</b>	<b>1</b>
<b>2. Applicability</b>	<b>1</b>
<b>3. Definitions</b>	<b>2</b>
<b>4. Handling</b>	<b>2</b>
<b>4.1 Collection of Street Sweepings</b>	<b>2</b>
<b>4.2 Storage</b>	<b>2</b>
<b>4.3 Preparation Prior to Use</b>	<b>3</b>
<b>5. Approved Uses, Restrictions &amp; Conditions - No Prior Approval Needed from MassDEP</b>	<b>3</b>
<b>5.1 Use at Landfills</b>	<b>3</b>
<b>5.2 Use as Fill in Public or Private Ways and Parking Lots</b>	<b>3</b>
<b>5.3 Use as Additive to Restricted Use Compost</b>	<b>4</b>
<b>5.4 Reuse as Anti-Skid Material</b>	<b>4</b>
<b>5.5 Reuse at Landfills Regulated Under MassDEP Policy #COMM-97-001</b>	<b>5</b>
<b>5.6 Use at Reclamation Soil Facilities Regulated Under MassDEP Policy #COMM 15-001</b>	<b>5</b>
<b>6. Approved Use, Restrictions &amp; Conditions - Prior Approval Needed from MassDEP</b>	<b>6</b>
<b>6.1 Use as Bulking Agent for Wastewater Sludge or Septage Disposal</b>	<b>6</b>
<b>7. Other Uses</b>	<b>6</b>
<b>8. Disposal</b>	<b>6</b>
<b>9. Record Keeping</b>	<b>6</b>
<b>10. Additional Information</b>	<b>7</b>

## 1. Policy Statement and Scope

This Policy explains MassDEP requirements for managing Street Sweepings. Street Sweepings are “solid waste” subject to the Massachusetts solid waste regulations. The options for managing Street Sweepings are as follows.

- Use the Street Sweepings in accordance with the preapproved uses described in Section 4 of this policy.
- Use the Street Sweepings for a beneficial use not included in the list of preapproved uses after obtaining a permit from MassDEP under the provisions of the solid waste regulations, 310 CMR 19.060, Beneficial Use of Solid Wastes.
- Dispose of Street Sweepings at a permitted solid waste landfill.

## 2. Applicability

This policy applies to the reuse or disposal of Street Sweepings that are generated in the ordinary and customary cleaning of roadways and parking lots. This policy does not apply to catch basin cleanings or Street Sweepings mixed with catch basin cleanings or any other type of wastes. The disposal and reuse of catch basin cleanings is discussed in the “Management of Catch Basin Cleanings” Fact Sheet issued by the MassDEP (<https://www.mass.gov/lists/massdep-solid-waste-policies-guidance-fact-sheets>).

This policy does not apply to the material generated as the result of the clean-up of an oil or hazardous material spill. However, Street Sweepings that are generated in the ordinary and customary maintenance of roadways and parking lots are not exempt from the Hazardous Waste Regulations, 310 CMR 30.000, and must be handled as hazardous waste when they exhibit any of the characteristics of a hazardous waste. If there is no evidence of unusual contamination, MassDEP does not require Street Sweepings to be routinely tested, but, as is the case with any waste, the generator has the ultimate responsibility for determining whether the waste is a hazardous waste.

Although Street Sweepings are not considered soil, they may be managed under Policy #COMM-97-001, “Reuse and Disposal of Contaminated Soil at Massachusetts Landfills”, in accordance with Section 5.5 of this policy.



### 3. Definitions

This section contains definitions of the important terms used in this Policy.

*Department or MassDEP* means the Massachusetts Department of Environmental Protection.

*Parking lots* mean publicly or privately owned paved areas that provide access for the general public to park their car while patronizing retail or service businesses. Parking lots also include the paved areas used by the employees at office parks and businesses.

*Private way* means the strip of land over and under a privately owned, paved road or highway.

*Public way* means the strip of land over and under a publicly owned, paved road or highway and includes the publicly owned land adjacent to the road or highway.

*Street Sweepings* means materials consisting primarily of sand and soil generated during the routine cleaning of roadways or parking lots but may also contain some leaves and other miscellaneous solid wastes collected during street sweeping. Street Sweepings do not include the material generated during the clean-up of a spill or material from other structures associated with a roadway such as catch basins.

*Urban center roads* mean local roads in central commercial and retail business districts and industrial and manufacturing areas.

### 4. Handling

#### 4.1 Collection of Street Sweepings

Although MassDEP does not regulate the collection of Street Sweepings, collection practices should be compatible with intended uses. Keeping sweepings from Urban Center Roads separate from sweepings from other areas will provide the generator of the Street Sweepings with the most options under this policy.

This policy does not cover sweepings known to be contaminated by spills, and such sweepings should be collected separately and kept segregated. Depending on the contamination and circumstances, the handling of contaminated sweepings may be governed by the Massachusetts Contingency Plan, 310 CMR 40.0000, the Massachusetts Hazardous Waste Regulations, 310 CMR 30.000, the Massachusetts Site Assignment Regulations for Solid Waste Facilities, 310 CMR 16.00 or the Massachusetts Solid Waste Management Facility Regulations, 310 CMR 19.000.

#### 4.2 Storage

Street Sweepings shall be temporarily stored prior to use, only when the following conditions are satisfied:

- Storage must be:
  - at the site where the sweepings are generated (e.g. at a parking area that was swept);
  - at a location, such as a Department of Public Works (DPW) yard, that is under the control of the governmental entity doing the sweeping or has contracted for the sweeping; or,

- at other locations with prior written approval from the appropriate MassDEP Regional Office.
- The Street Sweepings shall be protected from wind and rain to the extent necessary to prevent dust, erosion, and off-site migration;
- The Street Sweepings shall not be stored within the 100 foot buffer zone of a wetland or within wetland resource areas including bordering vegetative wetlands and riverfront areas;
- The Street Sweepings shall not be stored within 500 feet of a ground or surface drinking water supply;
- Storage of the Street Sweepings shall incorporate good management practice and result in no public nuisance; and
- Storage of the Street Sweepings must be temporary. Street Sweepings shall be used within one year of collection unless the MassDEP Regional Office where the Street Sweepings are stored grants a written extension. An extension may be granted when it is demonstrated that all storage conditions will continue to be satisfied and the stored Street Sweepings will be put to a specific identified use prior to the expiration of the extension period.

#### **4.3 Preparation Prior to Use**

Solid waste, such as paper, auto parts and other trash, shall be removed from all Street Sweepings prior to use. Solid waste screened from the Street Sweepings shall be disposed of at a permitted solid waste facility. Leaves, twigs and other organic matter should also be removed when good engineering practice indicates this is necessary to produce a material that is suitable for the intended use.

### **5. Approved Uses, Restrictions & Conditions-No Prior Approval Needed from MassDEP**

This policy allows Street Sweepings to be used in several applications. An approval from MassDEP is not required when the restrictions and conditions are adhered to as identified in this policy. However, Street Sweepings shall not be used unless prior approval is obtained from the owner of the location where the sweepings are to be used.

#### **5.1 Use at Landfills**

Street Sweepings may be used for daily cover at permitted lined solid waste landfills and need no prior MassDEP approval if the Street Sweepings satisfy the requirements for daily cover material specified at 310 CMR 19.130(15). A list of active permitted solid waste landfills can be found on the MassDEP website.

#### **5.2 Use as Fill in Public or Private Ways and Parking Lots**

Street Sweepings may be used for fill in public and private ways and parking lots without prior approval from MassDEP only when the following additional restrictions and conditions are observed:

- The Street Sweepings have not been collected from Urban Center Roads (see definition);
- Any collection, storage, or preparation for use of the Street Sweepings shall be in accordance with Sections 4.1 and 4.2 of this policy.
- The Street sweepings have been screened to remove all debris and solid waste and all debris/solid waste screened from the sweepings shall be disposed at a permitted solid waste facility (see Section 8);
- The Street Sweepings are kept above the level of the groundwater;
- The Street Sweepings are not used in designated "No Salt Areas";

- The Street Sweepings are not used within the 100 foot buffer zone of a wetland or within wetland resource areas including bordering vegetative wetlands and riverfront areas;
- The Street Sweepings are not used within 500 feet of a ground or surface drinking water supply;
- In public ways the Street Sweepings are used under the paved road surface or, except in residential areas, as fill along the side of the road within the public way;
- In private roadways or in residential areas the Street Sweepings are used only under the paved road surface; and
- In parking lots the Street Sweepings are used only under the paved parking surface.

### **5.3 Use As an Additive to Restricted Use Compost**

Street Sweepings may be used as an additive to compost without prior written approval from MassDEP only when the following additional restrictions and conditions are observed:

- The Street Sweepings have not been collected from Urban Center Roads (see definition);
- Any collection, storage, or preparation for use of the Street Sweepings shall be in accordance with Sections 4.1 and 4.2 of this policy.
- The Street Sweepings have been screened to remove all debris and solid waste and all debris and solid waste screened from the sweepings is disposed at a permitted solid waste facility (see Section 8);
- The compost is used only along public ways and parking lot areas;
- The compost is not used in residential areas;
- The compost is kept above the level of the groundwater;
- The compost is not used in designated "No Salt Areas";
- The compost is not used within the 100 foot buffer zone of a wetland or within wetland resource areas including bordering vegetative wetlands and riverfront areas; and
- The compost is not used within 500 feet of a ground or surface drinking water supply.

### **5.4 Reuse as Anti-Skid Material**

Street Sweepings may be used as a component to anti-skid material (e.g. street sanding material) without prior written approval from MassDEP only when the following additional restrictions and conditions are observed:

- The Street Sweepings have not been collected from Urban Center Roads (see definition);
- Any collection, storage, or preparation for use of the Street Sweepings shall be in accordance with Sections 4.1 and 4.2 of this policy;
- The Street Sweepings have been screened to remove all debris and solid waste and all debris and solid waste screened from the Street Sweepings is disposed at a permitted solid waste facility (see Sections 8);
- The anti-skid material/Street Sweepings are not used in designated "No Salt Areas";
- The anti-skid material/Street Sweepings are not used within the 100 foot buffer zone of a wetland or within wetland resource areas including bordering vegetative wetlands and riverfront areas; and
- The anti-skid material/Street Sweepings are not used within 500 feet of a ground or surface drinking water supply.

The use of Street Sweepings as anti-skid material in accordance with this policy is not a determination of the efficacy of the material for this purpose. Proper engineering review should be done to ensure the material works as intended.

### **5.5 Reuse at Landfills Regulated Under MassDEP Policy #COMM-97-001**

Street Sweepings may be reused at a permitted Massachusetts landfill and need no prior written MassDEP approval if the sweepings have been adequately characterized pursuant to the MassDEP Policy #COMM-97-001 and the Street Sweepings have been screened to remove debris and solid waste.

All screened debris and solid waste removed from Street Sweepings shall be disposed of at a permitted solid waste facility. Street Sweepings for use at the landfill may contain only incidental, randomly dispersed, de minimis quantities of ash and/or Solid Waste as defined in 310 CMR 16.000 and 310 CMR 19.000, which collectively shall comprise less than 1% by volume of the Street Sweeping materials, as determined by visual inspections. Any Street Sweeping materials approved and brought onto the landfill property for use at the landfill shall contain no more than 5% (by volume) of Asphalt Pavement, Brick, and Concrete (“ABC”) material (as defined in 310 CMR 19.000), as determined by visual inspection. Any such material must measure less than 6 inches in any dimension.

Persons who wish to send Street Sweepings to a landfill must comply with MassDEP Policy #COMM-97-001 which requires sampling of the Street Sweepings to demonstrate that the Street Sweepings meet the standards listed in the Policy.

### **5.6 Use at Reclamation Soil Facilities Regulated Under MassDEP Policy # COMM-15-01**

Street Sweepings may be used for fill at a permitted Reclamation Soil Facility (the Facility) and need no prior written MassDEP approval if the Street Sweepings have been adequately characterized pursuant to the Facility-specific Soil/Fill Management Plan and the Street Sweepings have been screened to remove debris and solid waste.

All screened debris and solid waste removed from Street Sweepings shall be disposed of at a permitted solid waste facility. Street Sweepings for use at the Facility may contain only incidental, randomly dispersed, de minimis quantities of ash and/or Solid Waste as defined in 310 CMR 16.000 and 310 CMR 19.000, which collectively shall comprise less than 1% by volume of the Street Sweeping materials, as determined by visual inspections. Any Street Sweeping materials approved and brought onto the property for use at the Facility shall contain no more than 5% (by volume) of ABC material, as determined by visual inspection. Any such material must measure less than 6 inches in any dimension.

Pursuant to Policy # COMM-15-01, persons who wish to send Street Sweepings to a Facility must sample and analyze the Street Sweepings as required by the Facility’s Soil/Fill Management Plan and demonstrate that the Street Sweepings meets the Facility’s acceptance criteria. Unless specifically addressed in a Facility’s Soil/Fill Management Plan, a minimum sampling frequency of 1 sample per 100 cubic yards is required for characterization of Street Sweepings originating from Urban Center Roads. Street Sweepings originating from non-Urban Center Roads may be sampled at a minimum of 1 sample per 500 cubic yards. Regardless of its point of origin, if the total quantity of Street Sweepings is less than 100 cubic yards, a minimum of one composite sample is required for characterization of the material. A list of active permitted Reclamation Soil facilities may be found at <https://www.mass.gov/soil-transport-re-use-and-disposal>.

## **6. Approved Use, Restrictions & Conditions- Prior Approval Needed from MassDEP**

This policy allows Street Sweepings to be used in several applications. Prior written approval from MassDEP is required when using the Street Sweepings as identified in this section of the policy. In addition, Street Sweepings shall not be used at a location until prior written approval is obtained from the owner of the location where the Street Sweepings are to be used.

### **6.1 Use as a Bulking Agent for Wastewater Sludge or Septage Disposal**

Street Sweepings may be used as a bulking material for wastewater treatment plant sludge or septage when the mixed material will be disposed in a permitted lined or unlined sludge or septage landfill in compliance with MGL Chapter 21, Sections 26-53 and MGL Chapter 83 Sections 6 & 7 provided that the appropriate MassDEP Regional Office's Bureau of Water Resources has granted prior written approval.

## **7. Other Uses**

Any use not approved in this policy requires a MassDEP permit under the Beneficial Use provisions of the Solid Waste Management Facility Regulations at 310 CMR 19.060. A "Beneficial Use Determination" (BUD) can be issued only after the submission of an application characterizing the waste and describing the proposed beneficial use.

## **8. Disposal**

While the beneficial use of Street Sweepings is strongly encouraged, MassDEP does not prohibit the disposal of Street Sweepings. Street Sweepings may be disposed in permitted solid waste landfills without prior approval from the Department.

## **9. Record Keeping**

Any entity using Street Sweeping for any use listed under sections 5.3 or 5.4 shall keep records for a period of three years of the source of the sweepings, the location of use and the amount of sweepings used.

## **10. Additional Information**

For additional copies of this policy, permit application forms or other MassDEP documents, call any MassDEP Regional Office and ask for the Service Center or visit <http://www.mass.gov/dep>. The permit application numbers for Beneficial Use Determinations are BWP SW 39, 40, 41 and 42.

Copies of all Massachusetts regulations, including the solid waste regulations, are available at the MassDEP website and may also be purchased from the State House Bookstore at 617-727-2834. The solid waste regulations are:

- 310 CMR 16.000, Site Assignment Regulations for Solid Waste Facilities: and,
- 310 CMR 19.000, Solid Waste Management Facility Regulations.

If you have technical questions about the policy, please call any MassDEP Regional Office and ask to speak with a staff member in the solid waste program

# SOP 17: Hazardous Materials Storage and Handling

## Introduction

A hazardous material is any biological, chemical, or physical material with properties that make it dangerous or potentially harmful to human health or the environment. Hazardous materials can be released to the environment in a variety of ways. When hazardous materials come into contact with rain or snow, the pollutants are washed into the storm sewer system and to surface waterbodies and/or groundwater. Hazardous materials associated with municipal facilities and their operations include, but are not limited to, oil, gasoline, antifreeze, fertilizers, pesticides, and de-icing agents and additives.

Municipally owned or managed facilities where hazardous materials are commonly stored and handled include:

- Equipment storage and maintenance yards
- Hazardous waste disposal facilities
- Hazardous waste handling and transfer facilities
- Composting facilities
- Materials storage yards
- Municipal buildings and facilities (e.g., schools, libraries, police and fire departments, town offices, municipal pools, and parking garages)
- Public works yards
- Solid waste handling and transfer facilities
- Vehicle storage and maintenance yards
- Water and wastewater facilities

Minimizing or eliminating contact of hazardous materials with stormwater can significantly reduce pollution of receiving waters. Proper hazardous material handling and storage also contributes to employee health, an organized workplace, and efficient operations. The goal of this written Standard Operating Procedure (SOP) is to provide guidance to municipal employees to help prevent stormwater pollution resulting from the handling and storage of hazardous materials. If services are contracted, this SOP should be provided to the contractor. The contract should also specify that the contractor is responsible for compliance with all applicable laws.

## Procedures

The Town of Foxborough will implement the following procedures for handling and storing hazardous materials to reduce the discharge of pollutants to the MS4:

### Handling, Loading, and Unloading

- Avoid loading/unloading materials in the rain and/or provide cover.
- Retrace areas where materials have been transferred to identify spills. If spills are found, immediately clean them up. Follow procedures in SOP 4: Spill Response and Cleanup.
- Time delivery and handling of materials during favorable weather conditions whenever possible (e.g., avoid receiving loads of sand during windy weather).

- Inspect containers for material compatibility and structural integrity prior to loading/unloading any raw or waste materials.
- Use dry cleanup methods (e.g., squeegee and dust pan, sweeping, and absorbents as last step) rather than hosing down surfaces.

### **Material Storage**

- Confine material storage indoors whenever possible. Plug or disconnect floor drains that lead to the stormwater system.
- Confine outdoor material storage to designated areas that are covered, on impervious surfaces, away from high traffic areas, and outside of drainage pathways.
- Store containers on pallets or equivalent structures to facilitate leak inspection and to prevent contact with wet floors that can cause corrosion. This technique also reduces incidences of container damage by insects and rodents.
- Store materials and waste in materially compatible containment units.
- Keep hazardous materials in their original containers.
- If materials are not in their original containers, clearly label all storage containers with the name of the chemical, the expiration date, and handling instructions.
- Maintain an inventory of all raw and waste materials to identify leakage. Order new materials only when needed.
- Provide secondary containment for storage tanks and drums with sufficient volume to store 110 percent of the volume of the material.
- Provide sufficient aisle space to allow for routine inspections and access for spill cleanup.
- Inspect storage areas for spills or leaks and containment units for corrosion or other failures.

### **Waste Treatment, Disposal, and Cleanup**

- Adopt a regular schedule for the pick-up and disposal of waste materials.
- Recycle leftover materials whenever possible.
- Substitute nonhazardous or less-hazardous materials for hazardous materials whenever possible.
- Protect empty containers from exposure to stormwater and dispose of them regularly to avoid contamination from container residues.

### **Employee Training**

- Employees who handle and use hazardous materials are trained once per year on these procedures.
- Employees are also trained on stormwater pollution prevention, illicit discharge detection and elimination (IDDE) procedures, and spill and response procedures.
- If services are contracted, the contractor should be given a copy of this and any applicable SOPs to ensure compliance with MS4 regulations.

### **Related Standard Operating Procedures**

1. SOP 4: Spill Response and Cleanup



# SOP 18: Winter Road Maintenance

## Introduction

Winter road maintenance includes snow removal and the use of salt, sand, or deicers to ensure safe winter driving conditions. Proper maintenance procedures and use and storage of materials can help reduce the discharge of pollutants, such as sand and salt, from the MS4 and to receiving waters. The goal of this written Standard Operating Procedure (SOP) is to provide guidance to municipal employees on the use and storage of salt and sand, minimizing the use of salt, evaluating opportunities for use of alternative materials, and ensuring that snow disposal activities do not result in disposal of snow into surface waters. If services are contracted, this SOP should be provided to the contractor. The contract should specify that the contractor is responsible for compliance with all applicable laws.

## Procedures

The Town of Foxborough will implement the following winter maintenance procedures to reduce the discharge of pollutants from the MS4:

### Equipment and Maintenance

- Calibrate equipment to reduce and optimize salt use and ensure deicing agents are being used efficiently. Provide employee training on proper calibration procedures.
- Do not overfill trucks with deicing materials as it may lead to spills.
- Encourage the use of automated application equipment like zero velocity spreaders.
- When possible, retrofit vehicles to include equipment such as on-board application regulators, temperature sensors for air and pavement, and anti-icing and pre-wetting equipment.
- Wash equipment using proper procedures to prevent pollutants from entering the stormwater system. Dry cleanup procedures should be used when possible. Vehicles dirtied from salt or sand application should be washed according to procedures in SOP 21: Operations and Maintenance of Municipal Vehicles and Equipment.
- Regularly inspect and maintain equipment to reduce the potential for leaks. See SOP 21: Operations and Maintenance of Municipal Vehicles and Equipment for more information.

### Anti-icing and Deicing

- Minimize the use and optimize the application of sodium chloride and other salt<sup>1</sup> (while maintaining public safety) and consider opportunities for use of alternative materials.
- Optimize sand and/or chemical application rates through the use, where practicable, of automated application equipment (e.g., zero velocity spreaders), anti-icing and pre-wetting techniques, implementation of pavement management systems, and alternate chemicals.
- Remove as much snow as possible using mechanical means like plowing, blowing, or shoveling before deicing to reduce the need for road salt or other deicing chemicals.
- When possible, use anti-icing practices to prevent ice formation and reduce the need for deicers.

---

<sup>1</sup> For purposes of the MS4 Permit, salt means any chloride-containing material used to treat paved surfaces for deicing, including sodium chloride, calcium chloride, magnesium chloride, and brine solutions.

- Apply anti-icing agents 1-2 hours before winter weather events to ensure optimal performance (can be applied up to 24 prior).
- Only apply road salt when the pavement temperature is above 15° F.
- When using deicers, use pre-wetting agents (e.g., salt brine) to help them work more efficiently and to reduce road salt scatter and bounce.
- Salt brine solution used for anti-icing and pre-wetting can be stored for up to a year –concentration should be tested before use. If temperatures fall below 0° F, use a circulator pump to prevent the brine from freezing.
- Use alternative deicing materials instead of sodium chloride as appropriate (e.g., calcium magnesium acetate, magnesium chloride, or calcium chloride).
- Avoid mixing road salt and sand. Doing so makes both the salt and sand work less efficiently and leads to over-application.
- Only apply enough deicer so that plows can remove the snow and ice. Adjust the application rate of deicers based on the type of storm, type of agent used, and anti-icing and pre-wetting techniques used.
- Perform unloading/loading of trucks on impervious surfaces whenever possible. These areas should be frequently cleaned and swept to reduce the tracking and runoff of salt and to capture any spills.
- Track the amount of deicer used and maintain records of the application of sand, anti-icing and/or de-icing chemicals to document the reduction of chemicals to meet established goals.

### **Storage of Deicing Materials**

- Prevent exposure of deicing product (salt, sand, or alternative products) storage piles to precipitation by enclosing or covering the storage piles. Implement good housekeeping, diversions, containment or other measures to minimize exposure resulting from adding to or removing materials from the pile. Store piles in such a manner as not to impact surface water resources, groundwater resources, recharge areas, and wells.
- Store materials under covered or enclosed areas and on impervious surfaces.
- Ensure that there are adequate drainage controls in storage areas to prevent runoff from entering the stormwater system.
- Follow appropriate loading and unloading procedures. If there are spills when loading or unloading materials, follow the protocol outlined in SOP 4: Spill Response and Cleanup.
- Frequently sweep near the storage/loading areas to reduce the amount of salt, sand, or other materials that is tracked out.
- For liquid deicing chemicals, provide secondary storage containment.
- Do not store road salt near drinking water supplies, surface water resources, groundwater resources, recharge areas, and wells. Follow proper storage guidelines from MassDEP (<https://www.mass.gov/guides/guidelines-on-road-salt-storage>).
- The plan will include the following for municipally maintained surfaces and facilities:
  - Starting the year the Salt Reduction Plan is completed, the Town of Foxborough will track the type of salt and amount used on all municipal roads, parking lots, and other surfaces.
  - The Salt Reduction Plan may include the following::

- Operational changes to deicing procedures, which may include: pre-wetting, pre-treating the salt stockpile, increased plowing before deicing, monitoring road surface temperatures, etc.
- The use of new or retrofitted equipment that includes pre-wetting capabilities, better calibration rates, or other capabilities that minimize salt use.
- Proper training for employees or contractors engaged in winter maintenance activities
- Regular calibration of spreading equipment.
- Designation of no-salt and/or low-salt zones.
- Measures to prevent exposures of salt stockpiles to precipitation and runoff (when applicable).
- An estimate of total tonnage of salt reduction expected by each activity.
- Adoption of guidelines for application rates for roads and parking lots (see *Winter Parking Lot and Sidewalk Maintenance Manual (Revised edition June 2008)* <http://www.pca.state.mn.us/publications/parkinglotmanual.pdf> and the application guidelines on page 17 of *Minnesota Snow and Ice Control: Field Handbook for Snow Operators (September 2012)* <http://www.mnltap.umn.edu/publications/handbooks/documents/snowice.pdf>)
- For privately owned facilities within the regulated MS4 area that discharge to the storm system:
  - The Town of Foxborough will establish an ordinance, bylaw, or other regulatory mechanism requiring measures to prevent exposure of any salt stockpiles to precipitation and runoff at all commercial and industrial properties.
- The completed Salt Reduction Plan will be submitted to USEPA along with the annual report following the Salt Reduction Plan's completion. Each subsequent annual report should include an update on the Plan's implementation progress and any updates to the Plan deemed necessary by the municipality, as well as the types and amount of salt applied to all municipally owned and maintained surfaces.
- The Town of Foxborough will follow proper snow storage and disposal protocol outlined by MassDEP to ensure that snow that has been potentially contaminated by road salt or other chlorides does not enter the MS4.

### **Snow Storage and Disposal**

- Snow should not be pushed or dumped into waterbodies or wetlands, into stormwater drainage swales or ditches, or on top of catch basins.
- Snow should not be stored near drinking water areas, waterbodies, or wetlands.
- Avoid storing snow in areas that are unstable, areas of potential erosion, or high points where snow may melt and collect debris as runoff before it enters the stormwater system.
- Consider sun exposure when storing snow. Snow in areas with higher sun exposure will melt faster but may require deicers if the snowmelt refreezes.
- Consider practices such as living snow fences to contain snow piles and reduce snow drifting.
- The MS4 Permit prohibits snow disposal into waters of the United States. Snow disposal and storage activities, including selection of appropriate snow disposal sites, will adhere to the MassDEP Snow Disposal Guidance, Guideline No. BWR G2015-01 (<http://www.mass.gov/eea/agencies/massdep/water/regulations/snow-disposal-guidance.html>).

- The Town of Foxborough currently disposes of snow at the vacant lot across from 70 Elm Street in compliance with MS4 regulations.

### **Reporting**

The Town of Foxborough will document and include the following information in its annual report:

- Road miles treated
- Type and amount of deicer used
- Equipment calibration records
- Employee training dates

### **Employee Training**

- Employees who perform winter road maintenance are trained once per year on these procedures and the proper operation of related equipment.
- Employees are also trained on stormwater pollution prevention, illicit discharge detection and elimination (IDDE) procedures, and spill and response procedures.
- If services are contracted, the contractor should be given a copy of this and any applicable SOPs to ensure compliance with MS4 regulations.

### **Related Standard Operating Procedures**

1. SOP 4: Spill Response and Cleanup
2. SOP 21: Operations and Maintenance of Municipal Vehicles and Equipment



# Department of Environmental Protection

One Winter Street Boston, MA 02108 • 617-292-5500

Charles D. Baker  
Governor

Karyn E. Polito  
Lieutenant Governor

Kathleen A. Theoharides  
Secretary

Martin Suuberg  
Commissioner

## Massachusetts Department of Environmental Protection Bureau of Water Resources Snow Disposal Guidance

**Effective Date:** December 23, 2019

**Applicability:** Applies to all federal, state, regional and local agencies, as well as to private businesses.

**Supersedes:** Bureau of Resource Protection (BRP) Snow Disposal Guideline No. BRPG97-1 issued December 12, 1997 and BRPG01-01 issued March 8, 2001; Bureau of Water Resources (BWR) snow disposal guidance issued December 21, 2015 and December 12, 2018.

**Approved by:** Kathleen Baskin, Assistant Commissioner, Bureau of Water Resources

**PURPOSE:** To provide guidelines to all government agencies and private businesses regarding snow disposal site selection, site preparation and maintenance, and emergency snow disposal options that are protective of wetlands, drinking water, and water bodies, and are acceptable to the Massachusetts Department of Environmental Protection (MassDEP), Bureau of Water Resources.

**APPLICABILITY:** These Guidelines are issued by MassDEP's Bureau of Water Resources on behalf of all Bureau Programs (including Drinking Water Supply, Wetlands and Waterways, Wastewater Management, and Watershed Planning and Permitting). They apply to all federal agencies, state agencies, state authorities, municipal agencies and private businesses disposing of snow in the Commonwealth of Massachusetts.

### INTRODUCTION

Finding a place to dispose of collected snow poses a challenge to municipalities and businesses as they clear roads, parking lots, bridges, and sidewalks. While MassDEP is aware of the threats to public safety caused by snow, collected snow that is contaminated with road salt, sand, litter, and automotive pollutants such as oil also threatens public health and the environment.

As snow melts, road salt, sand, litter, and other pollutants are transported into surface water or through the soil where they may eventually reach the groundwater. Road salt and other pollutants can contaminate water supplies and are toxic to aquatic life at certain levels. Sand washed into

This information is available in alternate format. Contact Michelle Waters-Ekanem, Director of Diversity/Civil Rights at 617-292-5751.

TTY# MassRelay Service 1-800-439-2370

MassDEP Website: [www.mass.gov/dep](http://www.mass.gov/dep)

Printed on Recycled Paper

waterbodies can create sand bars or fill in wetlands and ponds, impacting aquatic life, causing flooding, and affecting our use of these resources.

There are several steps that communities can take to minimize the impacts of snow disposal on public health and the environment. These steps will help communities avoid the costs of a contaminated water supply, degraded waterbodies, and flooding. Everything that occurs on the land has the potential to impact the Commonwealth's water resources. Given the authority of local government over the use of the land, municipal officials and staff have a critically important role to play in protecting our water resources.

The purpose of these guidelines is to help federal agencies, state agencies, state authorities, municipalities and businesses select, prepare, and maintain appropriate snow disposal sites before the snow begins to accumulate through the winter. Following these guidelines and obtaining the necessary approvals may also help municipalities in cases when seeking reimbursement for snow disposal costs from the Federal Emergency Management Agency is possible.

## **RECOMMENDED GUIDELINES**

These snow disposal guidelines address: (1) site selection; (2) site preparation and maintenance; and (3) emergency snow disposal.

### **1. SITE SELECTION**

The key to selecting effective snow disposal sites is to locate them adjacent to or on pervious surfaces in upland areas or upland locations on impervious surfaces away from water resources and drinking water wells. At these locations, the snow meltwater can filter into the soil, leaving behind sand and debris which can be removed in the spring. The following conditions should be followed:

- Within water supply Zone A and Zone II, avoid storage or disposal of snow and ice containing deicing chemicals that has been collected from streets located outside these zones. Municipalities may have a water supply protection land use control that prohibits the disposal of snow and ice containing deicing chemicals from outside the Zone A and Zone II, subject to the Massachusetts Drinking Water Regulations at 310 CMR 22.20C and 310 CMR 22.21(2).
- Avoid storage or disposal of snow or ice in Interim Wellhead Protection Areas (IWPA) of public water supply wells, and within 75 feet of a private well, where road salt may contaminate water supplies.
- Avoid dumping snow into any waterbody, including rivers, the ocean, reservoirs, ponds, or wetlands. In addition to water quality impacts and flooding, snow disposed of in open water can cause navigational hazards when it freezes into ice blocks.
- Avoid dumping snow on MassDEP-designated high and medium-yield aquifers where it may contaminate groundwater.
- Avoid dumping snow in sanitary landfills and gravel pits. Snow meltwater will create more contaminated leachate in landfills posing a greater risk to groundwater, and in gravel pits, there is little opportunity for pollutants to be filtered out of the meltwater because groundwater is close to the land surface.

- Avoid disposing of snow on top of storm drain catch basins or in stormwater drainage systems including detention basins, swales or ditches. Snow combined with sand and debris may block a stormwater drainage system, causing localized flooding. A high volume of sand, sediment, and litter released from melting snow also may be quickly transported through the system into surface water.

### *Recommended Site Selection Procedures*

It is important that the municipal Department of Public Works or Highway Department, Conservation Commission, and Board of Health work together to select appropriate snow disposal sites. The following steps should be taken:

- Estimate how much snow disposal capacity may be needed for the season so that an adequate number of disposal sites can be selected and prepared.
- Identify sites that could potentially be used for snow disposal, such as municipal open space (e.g., parking lots or parks).
- Select sites located in upland locations that are not likely to impact sensitive environmental resources first.
- If more storage space is still needed, prioritize the sites with the least environmental impact (using the site selection criteria, and local or MassGIS maps as a guide).

### *Snow Disposal Mapping Assistance*

MassDEP has an online mapping tool to assist in identifying possible locations to potentially dispose of snow. MassDEP encourages municipalities to use this tool to identify possible snow disposal options. The tool identifies wetland resource areas, public drinking water supplies and other sensitive locations where snow should not be disposed. The tool may be accessed through the Internet at the following web address:

<https://maps.env.state.ma.us/dep/arcgis/js/templates/PSE/>.

## **2. SITE PREPARATION AND MAINTENANCE**

In addition to carefully selecting disposal sites before the winter begins, it is important to prepare and maintain these sites to maximize their effectiveness. The following maintenance measures should be undertaken for all snow disposal sites:

- A silt fence or equivalent barrier should be placed securely on the downgradient side of the snow disposal site.
- Wherever possible maintain a 50-foot vegetated buffer between the disposal site and adjacent waterbodies to filter pollutants from the meltwater.
- Clear debris from the site prior to using the site for snow disposal.
- Clear debris from the site and properly dispose of it at the end of the snow season, and no later than May 15.

### 3. SNOW DISPOSAL APPROVALS

Proper snow disposal may be undertaken through one of the following approval procedures:

- Routine snow disposal – Minimal, if any, administrative review is required in these cases when upland and pervious snow disposal locations or upland locations on impervious surfaces that have functioning and maintained stormwater management systems have been identified, mapped, and used for snow disposal following ordinary snowfalls. Use of upland and pervious snow disposal sites avoids wetland resource areas and allows snow meltwater to recharge groundwater and will help filter pollutants, sand, and other debris. This process will address the majority of snow removal efforts until an entity exhausts all available upland snow disposal sites. The location and mapping of snow disposal sites will help facilitate each entity's routine snow management efforts.
- Emergency Certifications – If an entity demonstrates that there is no remaining capacity at upland snow disposal locations, local conservation commissions may issue an Emergency Certification under the Massachusetts Wetlands Protection regulations to authorize snow disposal in buffer zones to wetlands, certain open water areas, and certain wetland resource areas (i.e. within flood plains). Emergency Certifications can only be issued at the request of a public agency or by order of a public agency for the protection of the health or safety of citizens, and are limited to those activities necessary to abate the emergency. See 310 CMR 10.06(1)-(4). Use the following guidelines in these emergency situations:
  - Dispose of snow in open water with adequate flow and mixing to prevent ice dams from forming.
  - Do not dispose of snow in salt marshes, vegetated wetlands, certified vernal pools, shellfish beds, mudflats, drinking water reservoirs and their tributaries, Zone IIs or IWPA's of public water supply wells, Outstanding Resource Waters, or Areas of Critical Environmental Concern.
  - Do not dispose of snow where trucks may cause shoreline damage or erosion.
  - Consult with the municipal Conservation Commission to ensure that snow disposal in open water complies with local ordinances and bylaws.
- Severe Weather Emergency Declarations – In the event of a large-scale severe weather event, MassDEP may issue a broader Emergency Declaration under the Wetlands Protection Act which allows federal agencies, state agencies, state authorities, municipalities, and businesses greater flexibility in snow disposal practices. Emergency Declarations typically authorize greater snow disposal options while protecting especially sensitive resources such as public drinking water supplies, vernal pools, land containing shellfish, FEMA designated floodways, coastal dunes, and salt marsh. In the event of severe winter storm emergencies, the snow disposal site maps created by municipalities will enable MassDEP and the Massachusetts Emergency Management Agency (MEMA) in helping communities identify appropriate snow disposal locations.

If upland disposal sites have been exhausted, the Emergency Declaration issued by MassDEP allows for snow disposal near water bodies. In these situations, a buffer of at



least 50 feet, preferably vegetated, should still be maintained between the site and the waterbody. Furthermore, it is essential that the other guidelines for preparing and maintaining snow disposal sites be followed to minimize the threat to adjacent waterbodies.

Under extraordinary conditions, when all land-based snow disposal options are exhausted, the Emergency Declaration issued by MassDEP may allow disposal of snow in certain waterbodies under certain conditions. *A federal agency, state agency, state authority, municipality or business seeking to dispose of snow in a waterbody should take the following steps:*

- Call the emergency contact phone number [(888) 304-1133] and notify the MEMA of the municipality's intent.
- MEMA will ask for some information about where the requested disposal will take place.
- MEMA will confirm that the disposal is consistent with MassDEP's Severe Weather Emergency Declaration and these guidelines and is therefore approved.

During declared statewide snow emergency events, MassDEP's website will also highlight the emergency contact phone number [(888) 304-1133] for authorizations and inquiries. For further non-emergency information about this Guidance you may contact your MassDEP Regional Office Service Center:

**Northeast Regional Office, Wilmington, 978-694-3246**  
**Southeast Regional Office, Lakeville, 508-946-2714**  
**Central Regional Office, Worcester, 508-792-7650**  
**Western Regional Office, Springfield, 413-755-2114**

# SOP 19: Operations and Maintenance of Parks and Open Spaces

## Introduction

Parks and open space operations and maintenance activities commonly involve the operation of equipment such as mowers and tractors; disposal of waste from mowing, planting, weeding, raking, pruning, and trash collection; application of pesticides, herbicides, and fertilizers; cleaning and maintenance of park amenities such as play equipment, restrooms, and structures; and snow removal. These activities have the potential to generate contaminants such as sediments and toxic chemicals that may be picked up by rainwater, thereby entering the storm drainage system and receiving waters. The goal of this written Standard Operating Procedure (SOP) is to provide guidance to municipal employees to reduce the discharge of pollutants from the MS4 and to receiving waters as a result of parks and open space operations and maintenance. If services are contracted, this SOP should be provided to the contractor. The contract should specify that the contractor is responsible for compliance with all applicable laws.

The Town of Foxborough (the “Town”) performs a variety of operations and maintenance activities at its municipal parks and open spaces. Landscaping chemicals, including fertilizer, pesticides and herbicides, are stored indoors at the Department of Public Works.

Within two years of the effective date of the MS4 Permit, the Town will create an inventory of all municipal parks and open spaces and update this inventory annually (refer to the attached inventory template).

## Procedures

The Town will implement the following procedures at municipal parks and open spaces to reduce the discharge of pollutants from the MS4:

### General

- Repair damage to landscaped or mulch or vegetated bare areas as soon as possible to prevent erosion. If there are areas of erosion or poor vegetation, repair them as soon as possible, especially if they are within 50 feet of a surface water (e.g., pond, lake, or river).
- Remove (sweep or shovel) materials such as soil, mulch, and grass clippings from parking lots, streets, curbs, gutters, sidewalks, and drainage-ways.
- Do not clean up any unidentified or possibly hazardous materials found during maintenance; notify a supervisor immediately.

### Maintenance

- Wastewater from power washing signs, structures, or bleachers cannot be discharged into the stormwater system.
- When painting park equipment, use a drop cloth and clean up any spills immediately.
- Do not leave open containers on the ground where they may accidentally tip over.
- Sweep parking lots with a street sweeper and dispose of street sweepings in designated areas (see SOP 16: Streets and Parking Lots).

- Never wash debris from parking lots into the storm drain.

### **Mowing**

- Remove debris and trash from landscaped areas prior to mowing.
- Collect grass clippings and leaves after mowing. Do not blow or wash them into the street, gutter, or storm drains.
- Properly recycle or dispose of organic waste after mowing, weeding, and trimming.
- Reduce mowing frequencies wherever possible by establishing low/no-mow areas in lesser-used spaces.
- Brush off mowers (reels and decks) and tractors over grassy areas or in contained washout areas.
- Leave clippings on grassy areas or dispose of them in the trash or by composting.
- Do not hose off mowers over paved areas that drain into the MS4 or directly to surface waters.
- Follow proper vehicle and equipment maintenance procedures to prevent leaks (see SOP 21: Operations and Maintenance of Municipal Vehicles and Equipment)
- Do not allow grease from mowers to fall onto areas where they can be washed into the stormwater system.

### **Irrigation**

- Repair broken sprinkler heads as soon as possible.
- Only irrigate at a rate that can infiltrate into the soil to limit run-off.
- Avoid irrigating close to impervious surfaces such as parking lots and sidewalks.

### **Landscaping**

- When establishing new plantings, use alternative landscaping materials, such as drought resistant or native plants to reduce the need for irrigation and extensive application of fertilizers and pesticides.
- Follow proper fueling procedures for all equipment to ensure that petroleum products do not enter the stormwater system (see SOP 7: Fuel and Oil Handling Procedures).
- Fertilizers, herbicides, and pesticides should be properly used, stored, and handled (see SOP 12: Storage and Use of Pesticides and Fertilizer).
- The Town discharges into the following nitrogen-impaired waterbodies: Rumford River (MA62-39), Lake Mirimichi (MA62-118), Robinson Brook (MA62-14), Canoe River (MA-62-27), and Wading River (MA62-47), as well as the following phosphorus-impaired waterbodies: Neponset Reservoir (MA73034), Ganawatte Farm Pond (MA73037), and Neponset River (MA73-01). Under MS4 Permit requirements, the Town acknowledges that blowing organic waste material (grass cuttings, leaf litter) onto adjacent impervious surfaces is strictly prohibited.

### **Snow Removal**

- Store salt or sand for snow removal indoors under a roof or in a covered container and on impervious surfaces.
- See SOP 18: Winter Road Maintenance for more information on proper snow disposal and storage procedures.

- Any damage done to vegetated areas caused by plows or deicing materials should be repaired as early as possible in the spring.

### **Trash Management**

- All waste and recycling containers must be leak-tight with tight-fitting lids or covers.
- Place waste and recycling containers indoors or under a roof or overhang whenever possible.
- Clean and sweep up around outdoor waste containers regularly.
- Arrange for waste and recyclables to be picked up regularly and disposed of at approved disposal facilities.
- Do not wash out waste or recycling containers outdoors or in a parking lot.
- Conduct periodic inspections of waste areas to check for leaks and spills.
- Post signs indicating that “Carry in, Carry out” policy is in effect when trash containers are not provided or if containers are full. Signs should make note of relevant local fines for littering.
- Monitor waste and recycling containers at heavily-used sites and on holidays to ensure that there is no overflow.

### **Other Activities**

- Provide pet waste stations with bags and trash receptacles where pets are permitted. Post signs describing the proper disposal of pet waste.
- All portable toilets should be staked down in flat, secure locations where they are less likely to be knocked down or blown over. They should be placed in a location that would retain any spillage from washing into the MS4 or receiving waters. Ensure routine maintenance and cleaning of portable toilets.
- Identify undesirable waterfowl congregation areas and take steps to prevent waterfowl droppings from entering the stormwater system or surrounding waterbodies.
  - Take measures to discourage congregation near waterbodies and the storm system (e.g., use strobe lights or reflective tape, establish no-mow zones to reduce available feeding areas, or plant thick vegetation along waterlines). If waterfowl congregation cannot be managed, then isolate the drainage from congregation areas away from the storm system and waterbodies.
  - Install signage to educate the public on the negative effects of waterfowl feces entering the stormwater system or nearby waterbodies in order to discourage public feeding. Alternatively, enact feeding bans.

### **Employee Training**

- Employees who perform maintenance or other applicable work at municipal parks and open spaces are trained once per year on these procedures and the proper operation of related equipment.
- Employees are also trained on stormwater pollution prevention, illicit discharge detection and elimination (IDDE) procedures, and spill and response procedures.
- If services are contracted, the contractor should be given a copy of this and any applicable SOPs to ensure compliance with MS4 regulations.

## Attachments

1. Inventory of Municipal Parks and Open Spaces

## Related Standard Operating Procedures

- SOP 7: Fuel and Oil Handling Procedures
- SOP 12: Storage and Use of Pesticides and Fertilizer
- SOP 16: Streets and Parking Lots
- SOP 18: Winter Road Maintenance
- SOP 21: Operations and Maintenance of Municipal Vehicles and Equipment

**Inventory of Municipal Parks and Open Spaces  
Foxborough, Massachusetts**

Name of Park/Open Space	Location	Manager/Contact – Name, Position, Department, Phone Number	Potential Stormwater Pollutant Sources (e.g., trash containers, fertilizers, fuel)
Booth Playground	South Street, Foxborough, MA	David Laliberte, Tree & Park Supervisor, DPW, 508-543-1228	trash
Brown Cemetery (Wading River Burial Ground)	Cedar Street, Foxborough, MA	David Laliberte, Tree & Park Supervisor, DPW, 508-543-1228	
Charles G. Taylor Elementary School	196 South Street, Foxborough, MA	David Laliberte, Tree & Park Supervisor, DPW, 508-543-1228	trash
Chestnut Street Cemetery (Payson-Morse Burial Ground)	Chestnut Street, Foxborough, MA	David Laliberte, Tree & Park Supervisor, DPW, 508-543-1228	
Cocasset River Recreation (CRRRA) Fields	132 Mill Street, Foxborough, MA	David Laliberte, Tree & Park Supervisor, DPW, 508-543-1228	trash
Cocasset River Recreation Area (CRRRA) Camp	68 Mill Street, Foxborough, MA	David Laliberte, Tree & Park Supervisor, DPW, 508-543-1228	trash
Community Farmstand	Walnut Street, Foxborough, MA	David Laliberte, Tree & Park Supervisor, DPW, 508-543-1228	
East Street Cemetery (Hodges-Pratt Burial Ground)	East Street, Foxborough, MA	David Laliberte, Tree & Park Supervisor, DPW, 508-543-1228	
Ella G. Hill Playground	Community Way, Foxborough, MA	David Laliberte, Tree & Park Supervisor, DPW, 508-543-1228	
Foxborough High School Fields	120 South Street, Foxborough, MA	David Laliberte, Tree & Park Supervisor, DPW, 508-543-1228	trash
Green Street Cemetery (Sherman Burial Ground)	Green Street, Foxborough, MA	David Laliberte, Tree & Park Supervisor, DPW, 508-543-1228	
Historical Building	2 Cocasset Street, Foxborough, MA	David Laliberte, Tree & Park Supervisor, DPW, 508-543-1228	
Horseshoe Pits	Elm Street, Foxborough, MA	David Laliberte, Tree & Park Supervisor, DPW, 508-543-1228	

Town of Foxborough, Massachusetts  
SOP 19: Operations and Maintenance of Parks and Open Spaces

John J. Ahern Middle School Fields	111 Mechanic Street, Foxborough, MA	David Laliberte, Tree & Park Supervisor, DPW, 508-543-1228	trash
Mabelle M. Burrell Elementary School Fields	16 Morse Street, Foxborough, MA	David Laliberte, Tree & Park Supervisor, DPW, 508-543-1228	trash
Morse Cemetery (Boyden Burial Ground)	Cocassett Street, Foxborough, MA	David Laliberte, Tree & Park Supervisor, DPW, 508-543-1228	
Old Auditorium	Payson Road, Foxborough, MA	David Laliberte, Tree & Park Supervisor, DPW, 508-543-1228	
Payson Road Recreation Area	Payson Road, Foxborough, MA	David Laliberte, Tree & Park Supervisor, DPW, 508-543-1228	trash
Public Safety Building	8 Chestnut Street, Foxborough, MA	David Laliberte, Tree & Park Supervisor, DPW, 508-543-1228	trash
Public Works	70 Elm Street, Foxborough, MA	David Laliberte, Tree & Park Supervisor, DPW, 508-543-1228	trash, chemical storage, fertilizer storage
Town Common	School Street/South Street, Foxborough, MA	David Laliberte, Tree & Park Supervisor, DPW, 508-543-1228	trash
Town Hall	40 South Street, Foxborough, MA	David Laliberte, Tree & Park Supervisor, DPW, 508-543-1228	trash
Vincent M. Igo Elementary School	70 Carpenter Street, Foxborough, MA	David Laliberte, Tree & Park Supervisor, DPW, 508-543-1228	trash
Walden Farms Road Field	16 Walden Farms Road, Foxborough, MA	David Laliberte, Tree & Park Supervisor, DPW, 508-543-1228	
Retention Basins		David Laliberte, Tree & Park Supervisor, DPW, 508-543-1228	
Roadside Trees		David Laliberte, Tree & Park Supervisor, DPW, 508-543-1228	
Traffic Islands and Roundabouts		David Laliberte, Tree & Park Supervisor, DPW, 508-543-1228	

# SOP 20: Operations and Maintenance of Municipal Buildings and Facilities

## Introduction

Municipal buildings and facilities (schools, municipal offices, police and fire stations, municipal pools, parking garages, etc.) often house various chemicals, such as petroleum products and hazardous materials. As a result, these buildings and facilities are potential sources of pollutant discharges to the storm drainage system. The goal of this written Standard Operating Procedure (SOP) is to provide guidance to municipal employees on the use, storage, and disposal of chemicals and other stormwater pollutants to reduce the discharge of pollutants from the MS4. If services are contracted, this SOP should be provided to the contractor. The contract should specify that the contractor is responsible for compliance with all applicable laws.

Within two years of the effective date of the MS4 Permit, the Town will create an inventory of all municipal buildings and facilities and update this inventory annually (refer to the attached buildings and facilities inventory sheet).

## Procedures

The Town will implement the following procedures for municipally owned or operated buildings and facilities to reduce the discharge of pollutants from the MS4:

### **Handling, Storage, Transfer, and Disposal of Trash and Recyclables**

All liquid and solid waste must be disposed of properly. Some of the most common sources of pollution at municipal facilities are a result of littering, improper collection of debris, and improper disposal of solid or liquid waste.

- All waste and recycling receptacles must be leak-tight with tight-fitting lids or covers.
- Keep lids on dumpsters and containers closed at all times unless adding or removing material. If using an open-top roll-off dumpster, cover it and tie it down with a tarp unless adding materials.
- Place waste or recycling receptacles indoors or under a roof or overhang whenever possible.
- Locate dumpsters on a flat, paved surface and install berms or curbs around the storage area to prevent run-on and run-off.
- Do not locate dumpsters over or adjacent to catch basins.
- Prior to transporting waste, trash, or recycling, ensure that containers are not leaking (double bag if needed) and properly secure containers to the vehicle.
- Clean and sweep up around outdoor waste containers regularly.
- Clean up any liquid leaks or spills with dry cleanup methods.
- Arrange for waste or recycling to be picked up regularly and disposed of at approved disposal facilities.
- Never place hazardous materials, liquids, or liquid-containing wastes in a dumpster or recycling or trash container (see SOP 17: Hazardous Materials Storage and Handling).
- Do not wash trash or recycling containers outdoors or in parking lots.
- Conduct periodic inspections of solid and liquid waste storage areas to check for leaks and spills.
- Conduct periodic inspections of work areas to ensure that all wastes are being disposed of properly.



- In dumpster areas, regularly pick up surrounding trash and debris and regularly sweep the area.
- In compactor areas, regularly check the hydraulic fluid hoses and reservoir to ensure that there are no cracks or leaks. Regularly sweep the area.

### **Building Maintenance**

- When power washing buildings and facilities, ensure that the washwater does not flow into the storm system. Containment or filtering systems should be provided.
- Paint and other chemicals should not be applied on the outside of buildings when it is raining or prior to expected rain.
- When sanding, painting, power washing, etc., ensure that sites are properly prepared (e.g., use tarps) and cleaned (e.g., use dry cleaning methods) especially if they are near storm drains. Protect catch basins when maintenance work is conducted upgradient of them.
- When painting, use a drop cloth and clean up any spills immediately.
- Do not leave open containers on the ground where they may accidentally tip over.
- Buildings should be routinely inspected for areas of potential leaks.
- Do not discharge chlorinated pool water into the stormwater system. Water must be properly dechlorinated and tested before it is discharged.
- Streets and parking lots surrounding municipal buildings and facilities should be swept and kept clean to reduce runoff of pollutants and debris to the stormwater system.
- Streets and parking lots around buildings and facilities will be swept in accordance with the procedures in SOP 16: Streets and Parking Lots.

### **Storage of Petroleum Products and Potential Pollutants**

- Floor drains in storage areas should be disconnected from the stormwater system.
- Routinely inspect buildings and facilities for areas of potential leaks.
- For storage and handling procedures of petroleum products and potential pollutants, refer to SOP 17: Hazardous Materials Storage and Handling and SOP 7: Fuel and Oil Handling Procedures.
- For storage and handling procedures for fertilizers, pesticides, and herbicides, refer to SOP 12: Fertilizers, Pesticides, and Herbicides.
- All municipal buildings and facilities should be periodically inspected to address potential pollutant sources (e.g., leaks).

### **Spill Prevention Plan**

- Spill prevention plans such as Spill Prevention Control and Countermeasures (SPCC) Plans should be in place where applicable, based on inventories of material storage and potential pollutants. Coordinate with the local fire department if necessary.
- Spill SOPs are outlined in SOP 4: Spill Response and Cleanup.

### **Employee Training**

- Employees who perform maintenance or other applicable work at municipal buildings and facilities are trained at least once per year on these procedures and the proper operation of related equipment.
- Employees are also trained on stormwater pollution prevention, illicit discharge detection and elimination (IDDE) procedures, and spill and response procedures.

- If services are contracted, the contractor should be given a copy of this and any applicable SOPs to ensure compliance with MS4 regulations.

### **Attachments**

1. Inventory of Municipal Buildings and Facilities

### **Related Standard Operating Procedures**

1. SOP 4: Spill Response and Cleanup
2. SOP 7: Fuel and Oil Handling
3. SOP 12: Storage and Use of Pesticides and Fertilizer
4. SOP 16: Streets and Parking Lots
5. SOP 17: Hazardous Material Storage and Handling

**Inventory of Municipal Buildings and Facilities  
Foxborough, Massachusetts**

Name of Building/Facility	Location	Manager/Contact – Name, Position, Department, Phone Number	Potential Stormwater Pollutant Sources (e.g., trash containers, fertilizers, fuel)
Booth Recreational Complex	80 South Street, Foxborough, MA	Debbie Giardino, Director, Recreation,	Trash
Boyden Library	10 Bird Street, Foxborough, MA	Manuel Leite, Director, Library, (508) 543-1245	Trash
Charles G. Taylor Elementary School	196 South Street, Foxborough, MA	Anthony Moussalli , Facilities Manager, School, (508) 543-1676	Trash
Compost Site	East Belcher Road, Foxborough, MA	Tree Tech, (508) 543-5644	Chemical Toilets
Department of Public Works	70 Elm Street, Foxborough, MA	Chris Gallagher, Director, DPW, 508-543-1228	Trash, Salt Storage, Fuel, Vehicle Maintenance, Fertilizer
Foxborough High School	120 South Street, Foxborough, MA	Anthony Moussalli , Facilities Manager, School, (508) 543-1676	Trash
John J. Ahern Middle School	111 Mechanic Street, Foxborough, MA	Anthony Moussalli , Facilities Manager, School, (508) 543-1676	Trash
Mabelle M. Burrell Elementary School	16 Morse Street, Foxborough, MA	Anthony Moussalli , Facilities Manager, School, (508) 543-1676	Trash
Public Safety Complex	8 Chestnut Street, Foxborough, MA	Michael Kelleher, Chief, Fire, (508) 543-1230	Trash
Senior Center/Council on Aging	75 Central Street, Foxborough, MA	Marc Craig, Director, Human Services, (508) 543-1234	Trash
Town Hall	40 South Street, Foxborough, MA	Michael C. Johns, Assistant Town Manager, Office of the Town Manager, (508) 543-1219	Trash
Vincent M. Igo Elementary School	70 Carpenter Street, Foxborough, MA	Anthony Moussalli , Facilities Manager, School, (508) 543-1676	Trash

# SOP 21: Operations and Maintenance of Municipal Vehicles and Equipment

## Introduction

Regular maintenance of both municipal and contracted vehicles and heavy equipment not only prolongs the life of municipal assets but also helps reduce the potential for leaking of fluids associated with normal wear and tear. Potential pollutants include fuels, oil, antifreeze, brake fluid, solvents, and battery acid. The goal of this written Standard Operating Procedure (SOP) is to provide guidance to municipal employees to help reduce the discharge of pollutants from the MS4 as a result of leaks from vehicles and equipment. If services are contracted with respect to vehicles and equipment, this SOP should be provided to the contractor. The contract should also specify that the contractor is responsible for compliance with all applicable laws.

The Town of Foxborough undertakes various procedures in regards to its municipal vehicles and equipment. The Department of Public Works conducts routine vehicle maintenance and repairs at Vehicle Maintenance Garage in the center bay areas (5 & 6). The other bays (1-4 and 7-10) are used to store large vehicles and equipment for the Highway Division and Tree & Parks Division. Additional large vehicles and equipment are stored in the covered Vehicle and Equipment Storage building in the rear of the lot. Vehicle washing at the DPW is currently conducted outdoors at a designated wash area. However, the DPW is seeking funding to study alternatives for achieving compliance.

An inventory of all municipal vehicles and equipment is attached and shall be updated this inventory annually

## Procedures

The Town of Foxborough will implement the following procedures for municipally owned and operated vehicles and equipment to reduce the discharge of pollutants from the MS4:

### **Vehicle and Equipment Maintenance**

#### ***Vehicle Storage***

- Monitor vehicles and equipment for leaks and use drip pans as needed until repairs can be performed.
- When drip pans are used, avoid overtopping.
- Drain fluids from leaking or wrecked vehicles and parts as soon as possible. Dispose of fluids properly.
- Store and park vehicles on impervious surfaces and/or under cover or indoors whenever possible.

#### ***Vehicle Maintenance***

- Conduct routine inspections of heavy equipment and vehicles to proactively identify maintenance needs or potential leaks.
- Perform routine preventive maintenance to ensure heavy equipment and vehicles are operating optimally.
- Recycle or dispose of waste properly and promptly.

- Sweep and pick up trash and debris as needed.
- Do not dump any liquids or other materials outside, especially near or in storm drains or ditches.

### ***Body Repair and Painting***

- Conduct all body repair and painting work indoors.
- Minimize waste from paints and thinners. Calculate paint needs based on surface area.
- Use dry cleanup methods (vacuum, sweep) to clean up metal filings and dust and paint chips from grinding, shaving and sanding. Sweep debris from wet sanding after allowing it to dry overnight on the shop floor. Dispose of waste properly; never dump waste into storm or sanitary sewers.
- Use sanding tools equipped with vacuum capability to pick up debris and dust.

### ***Fueling***

- Fueling areas owned or operated by the municipality should be covered.
- Fueling areas should be evaluated to ensure that pollutants (e.g., gasoline or oil) do not enter the MS4. Follow the procedures in SOP 7: Fuel and Oil Handling.

### ***Material Management***

- Store materials and waste in labeled containers under cover and in secondary containment.
- Chemicals should not be combined in containers.
- Hazardous waste must be labeled and stored according to hazardous waste regulations. Follow the procedures in SOP 17: Hazardous Materials Storage and Handling.
- Carefully transfer collected fluids from containers into designated storage areas as soon as possible.
- Store new and used batteries securely to avoid breakage. Store indoors or in secondary containment to contain potential acid leaks. Recycle used batteries.
- Conduct periodic inspections of storage areas to detect possible leaks.
- Do not wash or hose down storage areas unless there is prior approval to collect and discharge the water into the sanitary sewer. Use dry cleanup methods whenever possible.
- Keep lids on containers. Store them indoors or under cover to reduce exposure to rain.
- Inspect and maintain all pretreatment equipment, including interceptors, according to the manufacturer's maintenance schedule and at least once per year.
- Proper spill protocol should be followed to prevent chemicals from entering the stormwater system. Follow the procedures in SOP 4: Spill Response and Cleanup.

### ***Parts Cleaning***

- Use designated areas for engine, parts, or radiator cleaning. Do not wash or rinse parts outdoors. If parts cleaning equipment is not available then capture parts cleaning fluids.
- Recycle cleaning solution. Never discharge waste to the sanitary sewer or storm sewer.
- Use steam cleaning or pressure washing of parts instead of solvent cleaning. Cleaning equipment must be connected to an oil/water interceptor prior entering the sanitary sewer.
- When using solvents for cleaning, drain parts over the solvent tank to avoid drips to the floor. Catch excess solutions and divert them back to tank. Allow parts to dry over the hot tank.

### **Vehicle and Equipment Washing**

Vehicle washing can result in the discharge of nutrients, sediment, petroleum products, and other contaminants to a surface water body or to a stormwater system. The MS4 Permit does not authorize the discharge of municipal vehicle washing byproducts into the MS4.

#### ***Outdoor Vehicle Washing Procedures***

Outdoor washing of municipal vehicles should be avoided unless wash water is contained in a tight tank or similar structure. Where no alternative wash system is available, and full containment of wash water cannot be achieved, adhere to the following procedures:

- Avoid discharge of any wash water directly to the storm drainage system or surface water (e.g., stream, pond, or drainage swale)
- Minimize the use of water to the extent practicable.
- Where the use of detergent cannot be avoided, use products that do not contain regulated contaminants. The use of a biodegradable, phosphate-free detergent is preferred.
- Do not use solvents except in dedicated solvent parts washer systems or in areas not connected to a sanitary sewer.
- Do not power wash, steam clean, or perform engine or undercarriage cleaning.
- Grassy and pervious (porous) surfaces may be used to promote direct infiltration of wash water, providing treatment before recharging groundwater and minimizing runoff to an adjacent stormwater system. Pervious surfaces or other infiltration-based systems should not be used within wellhead protection areas or within other protected resources.
- Impervious surfaces discharging to the storm drainage system should not discharge directly to a surface water unless treatment is provided. The treatment device should be positioned such that all drainage must flow through the device, preventing bypassing or short-circuiting.
- Periodic sweeping and/or cleaning should be completed to prevent accumulation from forming on the washing area.
- Maintain absorbent pads and drip pans to capture and collect spills or noticeable leaks observed during washing activities. Follow the procedures in SOP 4: Spill Response and Cleanup.
- Heavily soiled vehicles or vehicles dirtied from salting or snow removal efforts should follow the SOPs in the “Heavy Equipment Washing Procedures” below.

#### ***Indoor Vehicle Washing Procedures***

- Vehicles and equipment should be washed inside whenever possible to reduce runoff to the stormwater system.
- Where the use of detergent cannot be avoided, use products that do not contain regulated contaminants. The use of biodegradable, phosphate-free detergent is preferred.
- Detergents should not be used in areas where oil/water separators provide pre-treatment of drainage.
- Floor drains should be connected to a sanitary sewer or tight tank. Floor drains discharging to adjacent surface water bodies or engineered storm drain systems should be permanently plugged or otherwise abandoned before any vehicle wash activities are completed.
- Designate separate areas for routine maintenance and vehicle cleaning. This helps prevent

contamination of wash water by motor oils, hydraulic lubricants, greases, or other chemicals.

- Dry cleanup methods are recommended within garage facilities. Do not wash down floors and work areas with water.
- Bring smaller vehicles to commercial washing stations.
- Maintain absorbent pads and drip pans to capture and collect spills or noticeable leaks observed during washing activities. Follow the procedures in SOP 4: Spill Response and Cleanup.

### ***Heavy Equipment Washing Procedures***

- Mud and heavy debris removal should occur on impervious surfaces or within a retention area.
- Maintain these areas with frequent mechanical removal and proper disposal of waste.
- Impervious surfaces with engineered storm drain systems should not discharge directly to a surface water.
- Floor drains should be connected to a sanitary sewer or tight tank. Floor drains discharging to adjacent surface waterbodies or engineered storm drain systems should be permanently plugged or otherwise abandoned before any vehicle wash activities are completed.
- Where the use of detergent cannot be avoided, use products that do not contain regulated contaminants. The use of biodegradable, phosphate-free detergent is preferred.
- Detergents should not be used in areas where oil/water separators provide pre-treatment of drainage.
- Maintain absorbent pads and drip pans to capture and collect spills or noticeable leaks observed during washing activities. Follow the procedures in SOP 4: Spill Response and Cleanup.

### ***Engine and Steam Washing Procedures***

- Do not wash parts outdoors.
- Maintain drip pans and smaller containers to contain motor oils, hydraulic lubricants, greases, etc. and to capture and collect spills or noticeable leaks observed during washing activities, to the extent practicable. Follow the procedures in SOP 4: Spill Response and Cleanup.
- Where use of detergent cannot be avoided, use products that do not contain regulated contaminants. The use of a biodegradable, phosphate-free detergent is preferred.
- Avoid cleaning with solvents except in dedicated solvent parts washer systems. Make use of pressure washing and steam cleaning.
- Recycle clean solutions and rinse water to the extent practicable.
- Wash water should discharge to a tight tank or a sanitary sewer via an oil/water separator. Detergents should not be used in areas where oil/water separators provide pre-treatment of drainage.

### **Employee Training**

- Employees who perform work on/with municipal vehicles or equipment are trained once per year on these procedures and the proper operation of related equipment.
- Employees are also trained on stormwater pollution prevention, illicit discharge detection and elimination (IDDE) procedures, and spill and response procedures.
- If services are contracted, the contractor should be given a copy of this and any applicable SOPs to ensure compliance with MS4 regulations.

## **Attachments**

1. Inventory of Municipal Vehicles and Equipment

## **Related Standard Operating Procedures**

1. SOP 4: Spill Response and Cleanup
2. SOP 7: Fuel and Oil Handling
3. SOP 17: Hazardous Material Storage and Handling



Auto Fleet Schedule				
Description of Information				
Town of Foxborough				
Territory # 15				
#	Department	Year	Manufacturer & Model	Plate #
1	ANIM CONTROL	2014	FORD - F150 PICKUP	M91557
2	BLDG/INSPECT	2007	FORD - F150	M48036
3	BOH	2013	FORD - EXPLORER	M60610
4	COA	2014	FORD - E350 VAN	M55284
5	COA	2015	FORD - TAURUS	M95970
6	HIGHWAY	2014	CHEVROLET - DUMP TRUCK	M89260
7	FIRE	1994	EMERGENCY ONE - FIRE TRUCK	MF589
8	FIRE	2005	SPARTAN - DA421L-2142	MF188
9	FIRE	2006	FORD - F350 PICK UP	MF584
10	FIRE	2009	FORD - F550	MF5056
11	FIRE	2009	FORD - F550 FIRE TRUCK	MF9697
12	FIRE	2011	INTERNATIONAL - PUMPER	MF9598
13	FIRE	2012	HAULMARK - TRAILER	MFA382
14	FIRE	2012	INTERNATIONAL - AMBULANCE	MF129X
15	FIRE	2013	E ONE - TYPHOON	MF6150
16	FIRE	2014	CONTINENTAL CARGO - TRAILER	MFB349
17	FIRE	2015	FORD - EXPEDITION	MFA892
18	FIRE	2015	CHEVROLET - TAHOE	MFA919
19	FIRE	2016	FORD - F550 AMBULANCE	MF128X
20	FIRE	2017	FORD - EXPEDITION	MF7709
21	FIRE	2017	FORD - F250	MFA912
22	FIRE	2017	E-ONE - TYPHOON	MF591
23	FIRE	2018	FORD - EXPEDITION	MFC854
24	FIRE	2019	BRAVO - UTILITY TRAILER	M2411A
25	FIRE	2019	FORD - F550	MF127X
26	***Deleted***	1974	DODGE - DUMP TRUCK	M74715
27	HIGHWAY	1984	CATERPILLAR - LOADER	M33667
28	HIGHWAY	1984	HOLDER - SIDEWALK PLOW	M2901
29	***Deleted***	1987	BOMBARDIER - SW	M2903
30	***Deleted***	1989	HOLDER - TRACTOR	M87748
31	HIGHWAY	1992	STOW - TRAILER	M46254
32	HIGHWAY	1995	CASE - BACKHOE/LOADER AND PLOW	M53235
33	HIGHWAY	1997	INTERNATIONAL - DUMP TRUCK	M55427
34	HIGHWAY	1997	CROSS COUNTRY - 3HD12 TRAILER	M55280
35	HIGHWAY	1999	CROSS COUNTRY - TRAILER	M55343
36	HIGHWAY	1999	KUBOTA - TRACTOR	M55239
37	HIGHWAY	2001	FORD - F450 DUMP TRUCK	M67036
38	HIGHWAY	2001	INTERNATIONAL - 2254 DUMP TRUCK	M1887A
39	HIGHWAY	2001	CROSS COUNTRY - TRAILER	M67035
40	HIGHWAY	2002	BOMBARDIER - TRACTOR	M68050
41	HIGHWAY	2004	BOBCAT - LOADER	
42	HIGHWAY	2004	ELGIN - SWEEPER	M96400
43	HIGHWAY	2005	INTERNATIONAL - 7400	M95925
44	HIGHWAY	2005	JOHN DEERE - 624J 4WD LOADER	M71938
45	HIGHWAY	2006	INTERNATIONAL - 7400 SFA 4X2	M73871
46	***Deleted***	2006	FALCON - TRAILER	M74725
47	HIGHWAY	2007	FORD - EXPLORER	M1886A
48	HIGHWAY	2007	INTERNATIONAL - DUMP TRUCK	M88255
49	HIGHWAY	2007	BIG TOW - TRAILER	M75093
50	HIGHWAY	2007	JOHN DEERE - SKID STEER LOADER	M81243
51	HIGHWAY	2008	CHEVROLET - SILVERADO	M52208
52	HIGHWAY	2008	CROSS COUNTRY - TRAILER	M77605

53	HIGHWAY	2009	INTERNATIONAL - DUMP TRUCK	M76522
54	HIGHWAY	2009	MSV - TRACTOR	M81498
55	HIGHWAY	2010	CHEVROLET - TRUCK	M53237
56	HIGHWAY	2010	JOHN DEERE - LEAF VAC	M84778
57	HIGHWAY	2011	JOHN DEERE - BACKHOE	M87747
58	HIGHWAY	2011	STEPP - TRAILER	M85377
59	HIGHWAY	2011	PRINOTH - SIDEWALK TRACTOR	M84037
60	HIGHWAY	2012	FORD - ESCAPE	M84652
61	HIGHWAY	2012	CHEVROLET - SILVERADO	M84489
62	HIGHWAY	2012	MORBARK - BEEVER CHIPPER	M86339
63	HIGHWAY	2013	CHEVROLET - SILVERADO	M87635
64	HIGHWAY	2014	CAM - TRAILER	M85897
65	HIGHWAY	2014	PETERBILT - TRUCK	M92911
66	HIGHWAY	2014	CARMATE - TRAILER	M93990
67	HIGHWAY	2015	CHEVROLET - SILVERADO	M92347
68	HIGHWAY	2015	CHEVROLET - SILVERADO	M92728
69	HIGHWAY	2015	TORO - GROUNDMASTER MOWER	M94377
70	HIGHWAY	2017	PETERBILT - 348 TRUCK	M97178
71	HIGHWAY	2017	DODGE - RAM 5500	M97413
72	HIGHWAY	2017	TRACKLESS - MT	M98611
73	HIGHWAY	2017	WANCO - WVTMM TRAILER	M98612
74	HIGHWAY	2018	DODGE - RAM	M99030
75	HIGHWAY	2018	CAT - 938M WHEEL LOADER	M1461A
76	HIGHWAY	2018	CAT - 262D STEER LOADER	M1460A
77	HIGHWAY	2018	CARRY ON - TRAILER	M1056A
78	HIGHWAY	2019	CROSS COUNTRY - 612TL5	M3497A
79	HIGHWAY	2019	CROSS COUNTRY - 4HD20 FLAT BED TRAILER	M3496A
80	WATER	2019	MACK - DUMP/PLOW	M3313A
81	WATER	2019	CHEVROLET - SILVERADO	M2852A
82	WATER	2019	CHEVROLET - SILVERADO	M3760A
83	INSPECTIONS	2005	FORD - EXPLORER	M64020
84	INSPECTIONS	2016	FORD - ESCAPE	M94727
85	POLICE	1999	SMTM - TRAFFIC RADAR TRAILER	MP275A
86	POLICE	2004	NAVISTAR - 400 SERIES AMBULANCE	MP6998
87	POLICE	2007	FORD - EXPLORER (EXP OCT 2017) ~DELETING~	5AER40
88	POLICE	2008	BMW - 535 XI (EXP APRIL 2022)	289MT4
89	***Deleted***	2010	FORD - CROWN VICTORIA	MP186E
90	***Deleted***	2010	FORD - CROWN VICTORIA	MP375E
91	POLICE	2010	FORD - FUSION (EXP SEPT 2017)	561GV9
92	***Deleted***	2011	CHEVROLET - CAPRICE	MP432H
93	***Deleted***	2011	CHEVROLET - CAPRICE	MP431H
94	POLICE	2012	FORD - E350 VAN	MP98
95	POLICE	2012	CHEVROLET - TAHOE	MP430H
96	POLICE	2013	FORD - EXPLORER	MP3616
97	POLICE	2013	FORD - EXPLORER	MP3610
98	POLICE	2013	FORD - EXPLORER (EXP OCT 2017)	3AWP80
99	POLICE	2013	STEALTH - TRAILER	MP554H
100	POLICE	2014	FORD - TAURUS (EXP AUG 2021)	2SS148
101	POLICE	2014	FORD - ESCAPE	
102	POLICE	2014	FORD - EDGE (EXP AUG 2021)	143BR8
103	POLICE	2015	FORD - EXPLORER	MP6601
104	POLICE	2015	FORD - EXPLORER	MP667H
105	POLICE	2015	FORD - EXPLORER	MP579H
106	POLICE	2015	FORD - EXPLORER	MP6624
107	POLICE	2016	FORD - EXPLORER	MP240A
108	POLICE	2016	POLARIS - TRAILER (NO PLATE. DECAL ONLY)	MP4757
109	POLICE	2016	POLARIS - RANGER (NO PLATE. DECAL ONLY)	MP6623
110	POLICE	2017	FORD - EXPLORER	MP465A
111	POLICE	2017	FORD - EXPLORER	MPC484
112	POLICE	2017	FORD - EXPLORER	MPC485
113	POLICE	2017	FORD - EXPLORER	MP580H

114	POLICE	2017	FORD - EXPLORER	MP497E
115	POLICE	2017	FORD - EXPLORER (EXP AUG 2021)	4HB228
116	POLICE	2018	FORD - EXPLORER	MP476E
117	POLICE	2018	FORD - EXPLORER	MP6266
118	POLICE	2018	FORD - EXPLORER	MPD735
119	POLICE	2019	HARLEY DAVIDSON - MOTORCYCLE	MMC8250
120	POLICE	2019	HARLEY DAVIDSON - MOTORCYCLE	MMC8249
121	SCHOOL	2009	THOMAS - SCHOOL BUS (77 PASS)	SB29357
122	SCHOOL	2010	CHEVROLET - MID BUS	SB34805
123	SCHOOL	2011	CHEVROLET - BUS -DELETED-	SB36396
124	SCHOOL	2011	IC - SCHOOL BUS	SB19725
125	SCHOOL	2011	IC - SCHOOL BUS	SB20869
126	SCHOOL	2011	IC - SCHOOL BUS	SB20781
127	SCHOOL	2011	IC - SCHOOL BUS	SB19723
128	SCHOOL	2011	IC - SCHOOL BUS	SB19724
129	SCHOOL	2012	IC - SCHOOL BUS	SB36392
130	SCHOOL	2012	IC - SCHOOL BUS	SB36393
131	SCHOOL	2013	CHEVROLET - SILVERADO PICKUP	M90098
132	SCHOOL	2014	GMC - SAVCUT SCHOOL BUS	SB33498
133	SCHOOL	2014	IC - SCHOOL BUS	SB20870
134	SCHOOL	2014	IC - SCHOOL BUS	SB34811
135	SCHOOL	2015	BLUEBIRD - SCHOOL BUS	SB33500
136	SCHOOL	2015	BLUEBIRD - SCHOOL BUS	SB33499
137	SCHOOL	2015	THOMAS - SCHOOL BUS	SB39348
138	SCHOOL	2015	THOMAS - SCHOOL BUS	SB33485
139	SCHOOL	2016	FORD - F150	M94483
140	SCHOOL	2016	IC - SCHOOL BUS	SB40994
141	SCHOOL	2016	IC - SCHOOL BUS	SB40995
142	SCHOOL	2016	FORD - TRANSIT R2C	M88853
143	SCHOOL	2016	FORD - F150	M96885
144	SCHOOL	2017	FORD - T-150 VAN	M55446
145	SCHOOL	2017	BLUE BIRD - BUS	SB41139
146	SCHOOL	2017	IC - CE BUS	SB41141
147	SCHOOL	2017	IC - CE BUS	SB41140
148	SCHOOL	2018	BLUEBIRD - BBCV	SB44740
149	SCHOOL	2018	FORD - TRANSIT VAN	M97286
150	SCHOOL	2018	BLUEBIRD - BBCV 3310	SB41755
151	SCHOOL	2018	BLUEBIRD - BBCV 3310	SB42179
152	SCHOOL	2018	CHEVROLET - SILVERADO	M2378A
153	SCHOOL	2019	INTERCONTINENTAL - CE SCHOOL BUS	SB45688
154	SCHOOL	2019	INTERCONTINENTAL - CE SCHOOL BUS	SB45687
155	SCHOOL	2020	INTERCONTINENTAL - CE SCHOOL BUS	SB46548
156	WAT/SEW	2006	FORD - F350	M75331
157	WAT/SEW	2006	JOHN DEERE - 310SG BACKHOE/LOADER	M33821
158	WAT/SEW	2008	FORD - F150 PICKUP	M79252
159	WAT/SEW	2008	FORD - F150 PICKUP	M79253
160	WAT/SEW	2011	FORD - F350	M85689
161	WAT/SEW	2012	FORD - E150 VAN	M85618
162	WATER	1987	INGERSOLL RAND - PORTABLE AIR COMPRESSOR	M2872
163	WATER	2005	FORD - F350 4X4	M72986
164	WATER	2007	FORD - RANGER	M80038
165	WATER	2008	FORD - F250	M80034
166	WATER	2009	FORD - EXPLORER	M77548
167	WATER	2012	FREIGHTLINER - DUMP TRUCK	M87216
168	WATER	2013	EH WACHS - VALVE TRAILER	M89343
169	WATER	2014	FORD - ESCAPE	M92274
170	WATER	2014	FORD - F150 PICKUP	M89110
171	WATER	2014	WRIGHT - TRAILER	M91398
172	WATER	2016	CHEVROLET - SILVERADO K3500	M95373
173	WATER	2016	CHEVROLET - SILVERADO K3500	M95372
174	WATER	2016	CHEVROLET - SILVERADO	M95531



**Appendix F**  
**Sewer System Overflow Inventory**



**Town of Foxborough, MA**  
Department of Public Works  
Water & Sewer Division  
Sanitary Sewer Overflow (SSO) Inventory

DATE	LOCATION	CAUSE	ESTIMATED SSO (GAL)	RECEIVING WATER
06/07/15	131 MORSE STREET	Brownout caused pump failure	40,000	RUMFORD RIVER
04/12/16	131 MORSE STREET	Power Failure	60,000	RUMFORD RIVER
08/12/18	483 SOUTH STREET	Pump did not turn on.	50	
03/28/19	25 FOXBOROUGH BOULEVARD	Power shut off for non-payment - Private lift station	2,000	ROBINSON BROOK TRIBUTARY
10/04/20	131 MORSE STREET	Power outage. Backup generator serviced.	25,000	RUMFORD RIVER
11/16/21	385 CENTRAL STREET	Grease Blockage	600	RUMFORD RIVER

**Appendix G**  
**Outfall Priority Ranking**







**Appendix H**  
**Stormwater Pollution Prevention Plan**  
**Department of Public Works**

# Massachusetts Small MS4 General Permit

Stormwater Pollution Prevention Plan  
Department of Public Works  
(70 Elm Street)

Town of Foxborough, Massachusetts

June 30, 2020



## Stormwater Pollution Prevention Plan – Table of Contents

Section	Page
SECTION 1 – Introduction.....	1
SECTION 2 – Detailed Facility Assessment.....	3
SECTION 3 – Non-Structural Controls.....	22
SECTION 4 – Plan Implementation.....	25
SECTION 5 – SWPPP Certification .....	28

Figure	Page
Figure 2-1. Locus Map.....	29
Figure 2-2. Site Map.....	30

Table	Page
Table 2-1. Impaired Waters Receiving Drainage from the Facility.....	9
Table 2-2. Leak and Spill Cleanup Materials .....	20
Table 2-3. Significant Material Inventory .....	19
Table 2-4. Significant Leaks or Spills.....	21

Appendix	End of Document
A	Spill Documentation Forms
B	Training Documentation and Attendance Sheets
C	Facility Inspection Form

## SECTION 1 – Introduction

This Stormwater Pollution Prevention Plan (SWPPP) has been developed by Town of Foxborough to address the requirements of the United States Environmental Protection Agency's (USEPA's) 2016 National Pollutant Discharge Elimination System (NPDES) General Permit for Stormwater Discharges from Small Municipal Separate Storm Sewer Systems (MS4) in Massachusetts, hereafter referred to as the 2016 Massachusetts MS4 Permit.

The 2016 Massachusetts MS4 Permit requires that each permittee, or regulated community, address six Minimum Control Measures. These measures include the following:

1. Public Education and Outreach
2. Public Involvement and Participation
3. Illicit Discharge Detection and Elimination Program
4. Construction Site Stormwater Runoff Control
5. Stormwater Management in New Development and Redevelopment (Post Construction Stormwater Management); and
6. Good Housekeeping and Pollution Prevention for Permittee Owned Operations.

Under Measure 6, Good Housekeeping and Pollution Prevention for Permittee Owned Operations, the permittee is required, per Section 2.3.7.b of the 2016 Massachusetts MS4 Permit (page 50-54), to:

*...develop and fully implement a SWPPP for each of the following permittee-owned or operated facilities: maintenance garages, public works yards, transfer stations, and other waste handling facilities where pollutants are exposed to stormwater as determined by the permittee.*

*The SWPPP shall contain the following elements:*

1. *Pollution Prevention Team*
2. *Description of the facility and identification of potential pollutant sources.*
3. *Identification of stormwater controls*
4. *Management practices including: minimize or prevent exposure, good housekeeping, preventative maintenance, spill prevention and response, erosion and sediment control, management of runoff, management of salt storage piles or piles containing salt, employee training, and maintenance of control measures.*
5. *Site inspections*

This SWPPP accomplishes these requirements by:

- Providing an inventory of the materials and equipment at a facility that have the potential to cause stormwater pollution, and identifying locations where these materials are stored;
- Describing how stormwater is managed at a facility, including: engineered storm drain system conveyance; on-site pretreatment, treatment and infiltration systems; and discharges to surface water directly from the site;
- Reviewing activities that occur at the facility that represent a potential for stormwater pollution;
- Describing the Best Management Practices (BMPs) that will be implemented at the facility to reduce, eliminate and prevent the discharge of pollutants to stormwater;
- Identifying the employees responsible for developing, implementing, maintaining, and revising, as necessary, this SWPPP;
- Establishing a schedule and description of site inspections to be conducted at the facility to determine if the SWPPP is effective in preventing the discharge of pollutants;
- Serving as a tool for the facility employees, including a place to maintain recordkeeping associated with these requirements.

## SECTION 2 – Detailed Facility Assessment

### 2.1 Facility Summary

The Department of Public Works (DPW) is located at 70 Elm Street and is owned and operated by Town of Foxborough. The Locus Map in **Figure 2-1** shows the location of the facility within the Town of Foxborough.

The DPW is primarily responsible for activities at, and maintenance of, the facility.

### 2.2 Site Inspection

The site inspection associated with the development of this SWPPP was completed on June 25, 2020. The inspection was conducted by Lance DelPriore, Town Engineer.

During the site inspection, information related to activities at the site, vehicles stored at the site, fueling operations, material storage, transport of oil and other materials, and spill history was gathered.

### 2.3 Pollution Prevention Team

A Pollution Prevention Team for the DPW has been prepared and designated the task of developing, implementing, maintaining, and revising, as necessary, the SWPPP for this facility. Listed below are Pollution Prevention Team members and their respective responsibilities.

Responsibilities assigned to one or more members of the Pollution Prevention Team include:

- Implementing, administering and revising the SWPPP
- Regularly inspecting stormwater control structures
- Conducting stormwater training
- Recordkeeping

---

**Leader:** Chris Gallagher

**Title:** Director of Public Works

**Responsibilities:** Considers all stages of plan development, inspections, and implementation; coordinates employee training programs; maintains all records and ensures that reports are submitted; oversees sampling program. Responsible for certifying the completeness and accuracy of the SWPPP.

**Member:** Lance DelPriore

**Title:** Town Engineer

**Responsibilities:** Implements the preventative maintenance program; oversees good housekeeping activities; serves as spill response coordinator; conducts inspections; assists with employee training programs; conducts sampling/visual monitoring.

---

**Member:** Shaun Guillotte

**Title:** Highway Supervisor

**Responsibilities:** Assists in all components of the stormwater program, as needed.

---

**Member:** David Laliberte

**Title:** Tree & Park Supervisor

**Responsibilities:** Assists in all components of the stormwater program, as needed.

---

**Member:** Adam Rouille

**Title:** Equipment Maintenance Supervisor

**Responsibilities:** Assists in all components of the stormwater program, as needed.

---



## 2.4 Facility Description

The primary purpose of the DPW is to maintain town owned infrastructure and various other assets. Activities at the site are described in **SECTION 2.7**

The facility covers approximately 5.7 acres and contains the structures and other features shown on the Site Map in **Figure 2-2** and described in detail in the following sections. Components shown on the site map include:

- Location of the engineered drainage system, including catch basins, ditches, drain manholes, and treatment BMPs
- Outfalls to a receiving water, and the name of the receiving water
- Direction of surface water flow
- Structural stormwater pollution control measures
- Location of floor drains
- Vehicle washing areas
- Vehicle fueling areas
- Aboveground storage tanks (indoors and outdoors)
- Underground storage tanks
- Chemical storage areas
- Pesticide and fertilizer storage areas
- Salt storage areas
- Materials stockpiles
- Waste disposal areas.

## 2.5 Facility Structures

### Vehicle Storage and Maintenance

The Vehicle Maintenance Garage is located at the western portion of the property along Elm Street. Activities in this structure include all vehicle maintenance and repair for the Town of Foxborough. This building contains a total of seven floor drains in the garage bays, which discharge to an oil/water separator in the rear of the building. Other minor activities include sign making, administrative office space and a break room. Aerosol cans and other smaller products are properly stored in flammable materials storage cabinets. Petroleum products in 55 gallon drums are stored on secondary containment pallets.

### Maintenance and Storage Buildings

The small Steel Building located behind the Vehicle Maintenance Garage and is a fully enclosed, locked building, with no floor drains. This building is primarily used as auxiliary storage for the garage, including surplus tires and 55 gallon drums containing used oil filters, anti-freeze and motor oil.

The Paint Shed is small wooden shed used for the temporary storage of old and expended paint supplies before they are recycled. This building contains no floor drains.

The metal trailer behind the Vehicle Maintenance Garage contains the air compressor used by the garage, a 55 gallon drum of anti-freeze and various assorted tools.

The three metal trailers in the bus parking area are used to store landscaping equipment for the Tree & Parks Division. There are no floor drains in the trailers.

#### Vehicle Wash Bays or Recycling Systems

Vehicle washing is conducted outdoors at the Outdoor Vehicle Wash Pad at the north western portion of the lot along Elm Street inside of the enclosed bus parking area. The effluent drains to a catch basin which is tied directly into the site drainage system and discharges to the outfall in the back of the property. The DPW is currently considering options to relocate and/or disconnect its washing operations to comply with current stormwater discharge standards.

#### Storage of Deicing Materials

The salt/sand mix for roadway deicing is stored in the covered Salt Storage building. This building is covered with a water-tight canopy and the materials are fully contained within the building. The good housekeeping measure used to minimize the exposure resulting for adding to or removing stored materials includes sweeping the loading/mixing area regularly or when salt has accumulated on the paved surface.

#### Storage of Road Deicing Equipment

The covered Vehicle and Equipment Storage building is an open-ended, unheated, canopy structure which protects vehicle and equipment from direct exposure to the environment. It is located behind the garage at the back of the lot. There is a single catch basin which functions as a floor drain and connects to the oil/water separator at the rear of the Vehicle Maintenance Garage. This area is for storage only and no vehicle maintenance or repair work is conducted. The Tree & Park division also uses this building to store a pallet of individually bagged fertilizer.

#### Administrative Buildings

The DPW Offices building is located at the southwestern portion of the property. This building includes administrative space with a break room and basement document storage. There are no floor drains and roof leaders are connected to a subsurface infiltration basin at the rear of the building.

## **2.5.1 Additional Site Features**

### Aboveground Storage Tanks

Aboveground storage tanks (ASTs) at the DPW are used for storage of waste oil and deicer solution. An inventory of significant materials is included in **SECTION 2.12**.

A 500 gallon AST used for the storage of waste oil is located behind the Vehicle Maintenance Garage. The AST is not covered, but does have secondary containment formed out of concrete.

A 150 gallon AST used for the storage of motor oil is located inside Bay 4 of the Vehicle Maintenance. The AST is not covered, but does have secondary containment formed out of concrete.

A 2,500 gallons AST used for the storage of magnesium chloride deicing solution is located beside the opening of the covered Salt Storage building. The AST is not covered and is placed on an elevated pedestal to allow pumping into salt spreaders.

### Fuel Islands

The Public Works site contains one fuel island which is located along Elm Street between the Vehicle Maintenance Garage and the bus parking area. There are two fuel pumps, one for diesel and one for gasoline, and is used on a 24-hour basis for fueling of all Town of Foxborough vehicles. The island is not covered. Access to these fuel pumps is regulated through key fob system with unique user identification numbers. The location of the fuel island is such that all users are visible to personnel at the DPW.

### Emergency Generators

An emergency generator located directly behind the Vehicle Maintenance Garage on the south east corner provides backup power to the facility during outages. The generator, a Kohler model 100REOZJF, is fully enclosed and has 110% containment of its 209 gallon diesel day tank. The generator is on a concrete slab with bollards installed at each corner for impact protection.

### Oil/Water Separators

The Town of Foxborough maintains one oil/water separator at the DPW. The oil/water separator is located behind the Vehicle Maintenance Garage. This pretreatment structure has a cleanout manhole, and is pumped on an annual basis. The DPW is responsible for contracting this work, and maintains records on the pumpout activities. This oil/water separator provides treatment of flow from the Vehicle Maintenance Garage and Vehicle and Equipment Storage building. Floor drains in all areas where oil materials are used and/or where vehicles are stored receive pretreatment via this oil/water separator.

## Solid Waste Management

The Town of Foxborough maintains four dumpsters at the DPW. Dumpsters with lids are kept closed when not in use. No inappropriate materials were observed during the facility inspection. Two dumpsters are located inside the gate near the fuel island between the garage and the bus parking. One small dumpster is located beside the Paint Shed and is used for the collections fats, oils and grease containers from residents. A fourth large, open top, dumpster is located at the rear of the lot between the Salt Storage building and the Vehicle and Equipment Storage.

## Parking Areas

There are several designated parking areas at the DPW, each of which is an impervious surface. The front parking areas are used primarily for visitors to the DPW, Town of Foxborough-owned cars for daily use by DPW employees, and employees' personal vehicles. Additional outdoor parking for DPW trucks is located inside the gated area behind the garage. The Vehicle and Equipment Storage building is used parking of large equipment and vehicles.

## **2.6 Site Drainage**

No stormwater from adjacent properties impacts the DPW property.

### Sheet Flow

Drainage from the impervious surfaces at the DPW is directed primarily to the vegetated swale at the rear of the site.

### Engineered Drainage

Engineered drainage at the DPW includes a retention basin in front of the DPW Offices building which receives runoff from the parking area in the immediate vicinity, a subgrade infiltration basin which is connected to the roof leaders of the DPW Offices building, and a drainage system which collects the remainder of the site runoff and discharges to a vegetated swale at the rear of the lot. Maintenance of the catch basin structures, including sediment removal, is completed by the DPW.

### **2.6.1 Receiving Waters**

The final point of discharge for stormwater from this site is a wetland which feeds Henkes Brook. Henkes Brook is a tributary of the Rumford River. Per the 2016 Integrated List of Waters, the Rumford River has been categorized as a 303(d) List (Impaired) surface water. The impairment of this river, assigned the unique identifier MA62-63, is considered a Category 5, meaning that more than one designated use is impaired and that a TMDL will be required.

Impairments of this water body are shown in **Table 2-1**, below.

**Table 2-1. Impaired Waters Receiving Drainage from the Facility**

Water Body Name	ID	Category	Impairment(s)
Rumford River	MA62-63	5	(Physical substrate habitat alterations*)
			Benthic Macroinvertebrates
			Dioxin (including 2,3,7,8-TCDD)
			Fish Bioassessments
			Pentachlorophenol (PCP)
			Sedimentation/Siltation

The good housekeeping practices, preventative maintenance and Best Management Practices implemented at the facility are methods to limit potential negative impacts to stormwater. These practices are discussed in **SECTION 3** of this SWPPP.

## 2.7 Site Activities

The following activities occur at the facility:

- Facility or Building Maintenance
- Fueling Operations
- Landscaping
- Chemical unloading, handling, and storage (including paint, flammables, fertilizers, and pesticides)
- Painting
- Paving
- Sand storage
- Salt storage
- Solid waste management (including scrap metal)
- Tool storage
- Vehicle and equipment storage
- Vehicle and equipment maintenance/repair (including oil changes)
- Vehicle and equipment washing
- Waste Handling and Disposal
- Waste oil storage.

Below is a discussion of site activities and the potential pollutant sources associated with each, as well as measures taken to minimize pollution. Locations of each activity are shown on the Site Plan (**Figure 2-1**).

The DPW does not store hazardous materials other than those noted previously, and no obsolete vehicles or other potential sources of pollutants are kept in any structure at the DPW.

No solvent-based parts washers were observed in any structure at the DPW. Any hazardous materials are either collected by a third party vendor contracted by the Town of Foxborough on an annual basis, or collected at the annual Household Hazardous Waste Day (HHHD) that is hosted for the benefit of Town of Foxborough residents. Waste materials from DPW operations that may be collected at the annual HHHW Day include used motor vehicle fluids, such as used antifreeze and brake fluid. These materials are properly labeled and stored using appropriate Best Management Practices between the time of generation and disposal.

### **2.7.1 Stockpiles and Sand Storage**

#### Potential Sources of Stormwater Pollution

Sand stored in piles for use during construction and during winter plowing and deicing activities represents a potential source to stormwater pollution. Stockpiled materials such as gravel, loam, and crushed rock represent a similar source of pollution. When stored unprotected outdoors, sand piles and material stockpiles are exposed to precipitation. When the resulting eroded material enters the stormwater system, the sediment can quickly fill the sumps of catch basin structures, rendering them ineffective.

Mixing sand and salt for use in deicing activities poses an additional element of stormwater pollution, particularly if the mixing area is not fully enclosed and protected from the elements.

#### Pollution Prevention

To avoid contamination of stormwater by sand and other stockpiled materials, erosion and sediment control measures should be implemented at each storage site. When planning a location for a stockpile, a relatively level site away from slopes and water features should be selected.

Stockpiles can be stabilized by seeding or mulching if they are to remain exposed for more than two weeks, or can be covered with impermeable sheeting to protect the material from rainwater. If the stockpile location becomes a permanent storage site for sand, a roofed structure should be considered to reduce erosion.

Sediment barriers should be placed around the perimeter of the storage site to prevent any runoff carrying sand from entering storm drains and surface waters. If the weather becomes dry and windy, regular light watering of the stockpile and surrounding area will

provide effective dust control. Please refer to SOP 6, “Erosion and Sedimentation Control” for more information.

Sand that has been mixed with salt for use during winter plowing and deicing activities should always be stored in an enclosed and covered salt shed. Salt sheds should be constructed on level ground with an impervious base on which to store the salt/sand mixture. Under no circumstances should loose salt/sand mix be stored outside and unprotected. All mixing of salt and sand should take place within the salt shed or other covered, enclosed area.

Ensuring that the storage area is regularly swept and kept clean is an important good housekeeping practice.

### **2.7.2 Salt Storage**

#### Potential Sources of Stormwater Pollution

Salt stored in piles for use during winter plowing and deicing operations represents a potential major contributor to stormwater pollution. When stored unprotected outdoors, salt is exposed to precipitation, causing leachate with high chloride that can be discharged to the receiving water. Salt delivery and loading activities can contribute pollutants to stormwater if the material is not handled with care, and if spills from handling operations are not promptly cleaned up.

#### Pollution Prevention

To prevent stormwater pollution, all salt piles should be enclosed and covered in sheds to prevent exposure to precipitation. Salt sheds should be constructed on level ground with an impervious base on which to store the salt. The shed should prevent disturbance or migration of the salt by wind.

During delivery and loading activities, salt should be transferred to and from vehicles within the salt shed, whenever possible. Any spills during unloading and loading events should be tended to without delay. Ensuring that the salt storage area is regularly swept and kept clean is an important good housekeeping practice.

If it is not feasible to fully enclose the salt pile, the salt should be stored on an impervious base and covered with an impermeable membrane material. Under no circumstances should loose salt be stored outside and exposed to precipitation.

The area should not be hosed down to a storm drain as a cleaning method. To further limit stormwater pollution, an independent runoff collection system may be installed in the area of the salt storage to collect and convey runoff either directly to a treatment best management practice or to a sanitary sewer system, with approval from the operator of the sanitary sewer system.

### **2.7.3 Solid Waste Management**

#### Potential Sources of Stormwater Pollution

Solid waste production and storage locations present the threat to contaminate stormwater with pathogens, including bacteria and viruses, nutrients, including phosphorus and nitrogen, metals and sediments.

Solid waste may be classified as both hazardous and non-hazardous waste consisting of agricultural, construction and demolition, dead animals, industrial, municipal, and tire waste.

#### Pollution Prevention

To prevent or reduce the potential for stormwater pollution from solid waste management practices the following preventative maintenance procedures are recommended:

1. All staff shall be properly trained in correct solid waste management practices, including waste disposal and spill prevention and response. All employees shall also be knowledgeable of the potential hazards associated with solid waste handling and storage.
2. Each waste storage location shall be properly labeled and all significant sources of pollution shall be kept in a secure, covered and contained area.
3. The facility and storage containers shall remain locked at all times other than during normal hours of operation.
4. All waste storage containers and waste handling equipment shall be routinely inspected for signs of spills, leaks, corrosion or general deterioration.
5. The facility shall maintain spill response materials in accordance with SOP 4, "Spill Response and Cleanup".

### **2.7.5 Use or Storage of Pesticides or Fertilizers**

#### Potential Sources of Stormwater Pollution

Improper use and storage of fertilizers and pesticides can contribute to loadings of nutrients and toxic compounds to stormwater. Applying fertilizers and pesticides in quantities exceeding the manufacturer's recommendations does not make the product more effective. Rather, excess fertilizer and pesticide will be washed away during precipitation events, entering directly into stormwater and surface waters. The risk of incorrect use or spilling of fertilizers and pesticides increases when the chemicals are not handled by properly trained personnel. Contamination of stormwater can also occur during storage, when the pesticides and fertilizers are not being directly used. Leaks and spills from faulty containers can migrate to the storm drain system if not promptly controlled. Fires may break out if pesticides and fertilizers are not stored in the appropriate facilities.



## Pollution Prevention

To avoid contamination of stormwater by fertilizers and pesticides during application, all products should be used in strict accordance with the manufacturer's instructions and with local regulations. Soil testing should be performed before evaluating and selecting a fertilizer. Using the right type and amount of fertilizer for the location will help ensure that the proper nutrients are absorbed by the plants and will reduce runoff. Efficient use of pesticides is maximized when pesticides are applied at the life stage when the pest is most vulnerable. Pesticides must be handled and applied by individuals licensed with the Massachusetts Department of Agricultural Resources.

Fertilizers and pesticides should always be stored indoors in well-ventilated, dry locations. Floors of storage areas should be water tight, impervious, and provide spill containment. In case a spill or leak does occur, storage areas and any vehicles transporting fertilizers and pesticides should be equipped with a spill response kit. For more information, please refer to SOP 4 "Spill Response and Cleanup Procedures," and SOP 12 "Storage and Use of Pesticides and Fertilizer,".

### **2.7.6 Vehicle and Equipment Storage**

#### Potential Sources of Stormwater Pollution

Vehicle and equipment storage activities are a potential source of pollution due to the diesel fuel, gasoline, oil, hydraulic fluid, antifreeze and similar hazardous material or fuel the machinery may contain. In addition, vehicles or machinery may pick up pollutants during the course of offsite activities or at other facilities, and then deposit these pollutants at the storage facility.

#### Pollution Prevention

Regular visual inspection and maintenance of vehicles and equipment can greatly reduce the potential for pollution by finding and addressing leaks before pollution of the environment occurs. When in storage, vehicles and equipment should be kept on a covered slab or within a building with a common drain. Discharge to this drain shall be managed by an oil/ water separator (refer to SOP 11, "Oil/Water Separator Maintenance") to remove oils and gasoline. Vehicle washing activities shall not be completed in areas served by an oil/water separator.

No equipment should be kept in an area where leaks could result in pollutants entering catch basins, channels leading to outfalls, or the engineered storm drain system. If vehicles and equipment are stored outdoors, catch basins or engineered drainage system structures should include devices intended to remove oils and sediments prior to entering the system. These treatment devices should be inspected and replaced at the frequency recommended by the manufacturer.

### **2.7.7 Vehicle and Equipment Maintenance/Repair**

#### Potential Sources of Stormwater Pollution

Vehicle and equipment maintenance and repair often requires the use of harmful liquids such as fuels, oils, and lubricants, and has the potential for producing dust, scrap and by-products that may contain pollutants. Both accidental and purposeful spillage, i.e., a leaky oil pan needing repair vs. draining the pan during an oil change, can lead to situations where pollutants can potentially enter stormwater runoff if the situations are not approached properly. Although there is little potential for effecting stormwater, it should be noted that hazardous gases can be produced during maintenance and repair as well.

#### Pollution Prevention

Proper maintenance and repair for vehicles and equipment shall include a preliminary assessment of potential pollutant sources. This assessment shall be used to determine the best means of containing any potential spills or by-products of the situation at hand. Approved containers shall be used to capture hazardous liquids to then be disposed of according to applicable MassDEP and USEPA guidelines. If the project may produce hazardous dust that could come in contact and mix with any liquids, the proper containment shall be utilized.

Due to heavy metal accumulation in antifreeze, brake fluid, transmission fluid, and hydraulic oils, it is not recommended that any of these liquids are disposed of in the sanitary sewer system. Contaminated parts removed or replaced on any vehicles or equipment shall be disposed of properly.

All work shall take place on a covered slab or within a building with a common drain. Discharge to this drain shall be managed by an oil/ water separator (refer to SOP 11, “Oil/Water Separator Maintenance”) to remove oils and gasoline.

Maintenance and repairs shall not take place in areas prone to stormwater runoff or where pollutants could enter catch basins, channels leading to outfalls, or an engineered storm drain system. All catch basins or engineered drainage systems on site that could be affected by accidental spills should include devices intended to remove oils and sediments prior to entering the system. These treatment devices should be inspected and replaced at the frequency recommended by the manufacturer.

### **2.7.8 Vehicle and Equipment Washing**

#### Potential Sources of Stormwater Pollution

Vehicle and equipment washing activities are a potential source of pollution not only from petroleum products and pollutants deposited on the exterior of the equipment, but also from nutrients and sediment being washed into water bodies from the act of washing

itself. Although some cleaning agents are becoming environmentally friendly, many still contain regulated contaminants. Due to the possibility for multiple types of pollutants, vehicle and equipment washing activities have a high potential for degrading stormwater quality.

### Pollution Prevention

Outdoors, the use of a tight tank or other similar structure that can contain the wash water is ideal. If the wash water cannot be contained, it shall not be allowed to directly enter water bodies. Use phosphate free detergents that do not contain regulated contaminants, and avoid using solvents where the wash water may enter a sanitary sewer. Impervious surfaces may be used to promote infiltration and treatment before wash water enters the groundwater, but wash water coming from impervious pavement shall be treated to remove nutrients and petroleum products before entering an engineered storm drain system. Infiltration shall not be used within wellhead protection areas or other protected resource areas. Power washing, steam cleaning and engine and undercarriage washing shall not occur outdoors. Heavily soiled or vehicle dirtied from salting shall not be washed outdoors. All adjacent catch basins shall have a sump and be cleaned periodically, (refer to SOP 3, “Catch Basin Inspection and Cleaning”). All debris and particulate accumulation shall be removed and swept clean in all outdoor washing areas.

Washing vehicles and equipment indoors in the proper facilities is preferred over washing outdoors whenever possible. Indoor facilities shall have a common drain and it shall utilize a tight tank or other containment device to hold the wash water. The use of detergents shall be avoided and when the use of detergents cannot be avoided, use detergents free from phosphates and regulated contaminants. Detergents shall not be used when the discharge of this drain is controlled by an oil/ water separator (refer to SOP 11, “Oil/Water Separator Maintenance”). All drains that discharge directly to a water body of engineered storm drain system shall be plugged or abandoned. Dry clean-up methods such as vacuuming and sweeping shall be used whenever possible to avoid washing down floors with water.

For both outdoor and indoor washing, maintain absorbent pads and drip pans to collect spills and leaks observed during washing activities. Refer to SOP 4, “Spill Response and Cleanup Procedures” for more information.

### **2.7.9 Waste Handling and Disposal**

#### Potential Sources of Stormwater Pollution

Waste handling and disposal facilities and activities present a potential to contaminate stormwater with pathogens (including bacteria and viruses), nutrients, including phosphorus and nitrogen, fertilizers, pesticides and sediments.

There are several classifications of waste which contribute to stormwater pollution, including:

1. Solid Waste
2. Hazardous Materials and Waste
3. Pesticides and Fertilizers
4. Petroleum Products
5. Detergents

### Pollution Prevention

A variety of measures are considered appropriate to prevent pollution from waste handling and disposal activities, based on the waste classifications noted previously.

#### *Solid Waste*

1. Designate a waste collection area on the site that does not receive a substantial amount of runoff from upland areas and does not drain directly to a receiving water.
2. Ensure that containers have lids so they can be covered before periods of rain, and keep containers in a covered area whenever possible.
3. Schedule waste collection to prevent the containers from overflowing.
4. Clean up spills immediately and in accordance with SOP 4, "Spill Response and Cleanup Procedures".

#### *Hazardous Materials and Wastes*

1. To prevent leaks, empty and clean hazardous waste containers before disposing of them.
2. Never remove the original product label from the container. Follow the manufacturer's recommended method of disposal, printed on the label.
3. Never mix excess products when disposing of them, unless specifically recommended by the manufacturer.
4. Clean up spills immediately and in accordance with SOP 4 "Spill Response and Cleanup".

#### *Pesticides, Fertilizers and Petroleum Products*

1. Do not handle the materials more than necessary.
2. Store materials in a dry, covered, contained area.
3. Clean up spills immediately and in accordance with SOP 4, "Spill Response and Cleanup".

#### *Detergents*

1. Never dump wastes containing detergents to a storm drain system. All wastes containing detergents shall be directed to a sanitary sewer system for treatment at a wastewater treatment plant.

In addition to the pollution prevention requirements a waste management plan is recommended. The plan shall include employee training and signage informing individuals of the hazards associated with improper storage, handling and disposal of

wastes. It is imperative that all employees are properly trained and follow the correct procedures to reduce or eliminate stormwater pollution. Routine visual inspection of storage and use areas is critical. The visual inspection process shall include identification of containers or equipment which could malfunction and cause leaks or spills. The equipment and containers shall be inspected for the following:

1. Leaks
2. Corrosion
3. Support or Foundation Failure
4. Other Deterioration

In the case a defect is found, immediately repair or replace.

### **2.7.10 Waste Oil Storage**

#### Potential Sources of Stormwater Pollution

When not stored properly, waste oil can be a potential source of petroleum in stormwater. Waste oil containers can leak, and spills can occur while during transportation activities.

#### Pollution Prevention

All waste oil containers should be properly labeled and stored with secondary containment. Containers should be regularly inspected for rust, leaks, or other signs of deterioration. Defective containers should be promptly removed and replaced. A spill response kit should be located wherever waste oil is stored. Facility personnel should know where the spill kit is located and be familiar with the procedures outlined in SOP 4 “Spill Response and Cleanup Procedures”. Used oil filters should also be properly disposed.

Care should be taken when transferring used oil to and from storage containers. For additional information see SOP 7 “Fuel and Oil Handling Procedures”.

Waste oil should be stored indoors or under a covered structure to prevent exposure to precipitation. Floor drain in waste oil storage areas should drain to an oil/water separator rather than the storm drain system. See SOP 11 “Oil/Water Separator Maintenance” for further information.

When possible, steps should be taken to recycle waste oil or reduce the amount generated.

## **2.8 Vehicle and Equipment Inventory**

Vehicles and major equipment stored and maintained at the facility are attached to SOP 21 “Operations and Maintenance of Municipal Vehicles and Equipment”.

## 2.9 Location of Leak and Spill Cleanup Materials

Leak and spill cleanup materials are stored at the DPW in order to facilitate rapid response. Locations and types of leak and spill cleanup materials are identified in **Table 2-2**.

**Table 2-2. Leak and Spill Cleanup Materials**

Building or Area	Location	Materials Available

## 2.10 Allowable Non-Stormwater Discharges

A non-stormwater discharge is defined as any discharge or flow to the engineered storm drain system that is not composed entirely of stormwater runoff.

Allowable non-stormwater discharges that occur at this facility include:

- Water line flushing
- Uncontaminated ground water infiltration (as defined at 40 CFR § 35.2005(20))
- Uncontaminated pumped ground water
- Discharge from potable water sources
- Foundation drains
- Air conditioning condensation
- Footing drains
- Street wash waters

It has been determined that the above non-stormwater discharges at DPW do not represent a significant contribution of pollution to the MS4 or the waters of the United States. Therefore, these are considered to be authorized under the current MS4 permit.

## 2.11 Existing Stormwater Monitoring Data

No historical stormwater monitoring data has yet been collected at the DPW. Wet weather sampling and screening shall be conducted at the primary outfall at the rear of the lot.

## 2.12 Significant Material Inventory

Materials stored include those specified in **SECTION 2.7**, “Site Activities”. An inventory of these materials at the DPW is included in **Table 2-3**, which also reviews the likelihood for each identified material to come in contact with stormwater. The type of container has also been identified. Oil, gasoline, and other petroleum-based materials are listed separately in the table. The locations of these material storage areas are provided on the Site Plan in **Figure 2-2**.

A complete list of hazardous materials has been inventoried by HazCompliance LLC and an online database complete with associated Material Safety Data Sheets (MSDS) can be found at [www.hazcompliance.com](http://www.hazcompliance.com).

**Table 2-3. Significant Material Inventory**

Material	Storage Location	Quantity	Potential Pollutant	Covered (C) or Enclosed (E)	Likelihood of Contact with Stormwater
<b>Petroleum-Based Compounds</b>					
Diesel fuel	Fuel Island	6,000 gal. (UST)	Petroleum hydrocarbons	No	Possible
Gasoline	Fuel Island	10,000 gal. (UST)	Petroleum hydrocarbons	No	Possible
Hydraulic Fluid	Bay 4 Steel Building	275 gal (AST) 55 gal (AST)	Petroleum hydrocarbons	Yes Yes	Unlikely Unlikely
Motor Oil	Bay 4 Bay 5 Steel Building	55 gal (AST) 315 gal (AST) 165 gal (AST)	Petroleum hydrocarbons	Yes Yes Yes	Unlikely Unlikely Unlikely
Lubricants	Bay 4	Containers < 55 gal	Petroleum hydrocarbons	Yes	Unlikely
Transmission Fluid	Bay 4	110 gal (AST)	Petroleum hydrocarbons	Yes	1
Waste Oil	Behind Garage Steel Building	500 gal. (AST) 110 gal (AST)	Petroleum hydrocarbons	No Yes	Possible Unlikely
Other:	N/A	N/A		N/A	N/A
<b>Total Volume of Oil At Facility = 1,585 gallons (AST); 16,000 gallons (UST)</b>					
<b>Non-Petroleum Significant Materials</b>					
Antifreeze	Trailer	55 gal	Ethylene glycol; potential source of BOD	Yes	Unlikely
Asphalt	Back Corner Lot		Sediments	No	Possible
Batteries, Used Lead Acid	Bay 5	Approx. 20	Lead, sulfuric acid; possible particulate matter and residual oil	Yes	Unlikely
Deicer- Magnesium Chloride (liquid)		2,500 gal (AST)	Chlorides	No	Possible
Deicer- Road Salt	Salt Storage Building		Chlorides	Yes	Possible
Fertilizers	Vehicle Storage Bldg	Pallet	Nutrients	Yes	Unlikely
Paint, Latex	Paint Shed		Petroleum constituents, including volatile and	Yes	Unlikely

Material	Storage Location	Quantity	Potential Pollutant	Covered (C) or Enclosed (E)	Likelihood of Contact with Stormwater
			semivolatile organic compounds		
Paint, Oil-Based	Paint Shed		Petroleum constituents, including volatile and semivolatile organic compounds	Yes	Unlikely
Solid Waste, for Disposal	Dumpsters		Particulate matter, solids, metals		
Spill response material (Speedi Dri or similar)	All Potential Spill Locations		Particulate matter, solids, residual oil.		

### 2.13 Applicability of Spill Prevention, Control and Countermeasure (SPCC) Requirements

Under federal regulations 40 CFR Part 112 (and Amendments), a Spill Prevention, Control, and Countermeasure (SPCC) Plan is required when a facility has an aboveground oil storage capacity greater than 1,320 gallons, when including containers with a capacity of 55 gallons or more. The DPW does have aboveground oil storage capacity that exceeds 1,320 gallons.

### 2.14 Description of Significant Material Storage Areas

Many activities at the DPW which involve the materials included in **Table 2-3** occur within contained garages or bays. These activities may include minor equipment/vehicle repair, oil changes, repainting, lubrication, and parts replacement.

Fueling of all Town of Foxborough vehicles occurs at the Fuel Island located at the DPW. All bulk delivery of fuel to the Fuel Island is monitored by a DPW employee.

The DPW emergency generator is fueled with diesel as needed. The diesel fuel is delivered directly to the storage tank, which is internal and has secondary containment. All bulk delivery of fuel to the emergency generator is monitored by a DPW employee.

Waste oil and other used motor fluids are stored in a tank behind the garage which has internal and secondary containment. Used oil filters are stored in two 55 gallon drums which are placed on secondary containment pallets. All delivery of waste oil to the facility occurs within the DPW and is monitored by a DPW employee.

Salt and sand mixture is store within the Salt Storage Building. Deicing solution is stored in a tank beside the building opening. Delivery of deicing materials to the Salt Storage Building is monitored by a DPW employee.



## 2.15 List of Significant Leaks or Spills

Significant leaks or spills that occurred at the DPW in the last three years are shown in **Table 2-4**.

**Table 2-4. Significant Leaks or Spills**

Building or Area	Material	Volume

Forms included in **Appendix A** will be used to document any spill or leak that occurs at the facility in the future.

## 2.16 Structural BMPs

Structural BMPs include onsite constructed systems that provide pretreatment or treatment of stormwater flows. The following structural BMPs are presently used at the DPW to maintain water quality.

### 2.16.1 Pretreatment Structural BMPs

- Oil/Grit Separators
- Sediment Forebays
- Infiltration trench

### 2.16.2 Treatment Structural BMPs

- Subsurface Infiltration Bed
- Vegetated swale
- Dry extended detention basin

## 2.17 Sediment and Erosion Control

A network of catch basins collect most of the stormwater runoff at the DPW site and discharge to an outfall at the rear of the lot. Catch basins are routinely inspected and cleaned to prevent sedimentation build up.

## SECTION 3 – Non-Structural Controls

### 3.1 Good Housekeeping

Good housekeeping practices are activities, often conducted daily, that help maintain a clean facility and prevent stormwater pollution problems. The following is a list of good housekeeping measures that are practiced at the facility:

- All fluid products and wastes are kept indoors.
- Fueling of small equipment is completed indoors.
- All floor drains present within garage bays drain to an oil/water separator.
- Spill materials and cleanup kits are maintained at all locations where oil materials are used, stored, or may be present, including at Fuel Islands.
- Used spill cleanup materials are disposed of properly.
- Materials are stored indoors or in covered areas to minimize exposure to stormwater.
- Lead-acid batteries are stored indoors and within secondary containment.
- Hazardous materials storage lockers with spill containment are used. Storage areas are located away from vehicle and equipment paths to reduce the potential of accident related leaks and spills.
- Storage drums and containers are not located close to storm drain inlets.
- All hazardous material storage areas and containers have proper signage, labels, restricted access, locks, inventory control, overhead coverage, and secondary containment.
- All materials, waste oil storage containers, and gas cans are properly labeled.
- Oil/water separators and catch basins are maintained regularly and properly.
- Speedi Dri (or similar absorbent) is readily available and used for appropriate spills.
- Spill kits are located in areas where fluids are stored or where activities may result in a spill.
- Tools and materials are returned to designated storage areas after use.
- Waste materials are properly collected and disposed of.
- Different types of wastes are separated as appropriate.
- Regular waste disposal is arranged.
- Work areas are clean and organized.
- Work areas are regularly swept or vacuumed to collect metal, wood, and other particulates and materials.
- Obtain only the amount of materials required to complete a job.
- Materials are recycled when possible.
- Staff is familiar with manufacturer directions for proper use of materials and associated Safety Data Sheets (SDSs).
- Staff is familiar with proper use of equipment.
- Bollards, berms, and containment features are in place around areas and structures where fluids are stored.

- Drip pans are used for maintenance operations involving fluids and under leaking vehicles and equipment waiting repair.

The facility maintains a supply of spill cleanup materials at many buildings on site, and will maintain this inventory. An inventory of spill containment, control, and cleanup materials and spill kits maintained at the DPW was shown in **Table 2-3**.

### 3.2 Preventative Maintenance

Preventative Maintenance can minimize the occurrence of stormwater pollution by addressing issues before they become problems. Vehicles and equipment should be regularly inspected to prevent leaks of fuel, oil, and other liquids. Structural stormwater controls should be regularly maintained to prevent inadequate performance during storm events.

The following is a list of preventative maintenance procedures practiced at the facility

- All staff members are aware of spill prevention and response procedures.
- All staff members have received formal spill prevention and response procedure training.
- All equipment fueling procedures are completed by qualified personnel trained in spill response procedures.
- Hydraulic equipment is kept in good repair to prevent leaks.
- Vehicle storage areas are inspected frequently for evidence of leaking oil.
- Material storage tanks and containers are regularly inspected for leaks.
- All material and bulk deliveries are monitored by facility employees.
- All waste oil is fully contained and the containers are inspected regularly.

### 3.3 Best Management Practices

In a SWPPP, existing and planned BMPs are identified that will prevent or reduce the discharge of pollutants in stormwater runoff for each area of concern listed in **SECTION 2**.

To prevent or reduce the potential of stormwater contamination from petroleum products, the following BMPs shall continue to be followed:

1. Follow Standard Operating Procedures (s) during delivery of waste oil to the equipment/waste oil storage bay.
2. Follow Standard Operating Procedures during delivery of bulk oil to the emergency generator and bulk fuel to the Fuel Island.
3. Minimize the volume of gasoline stored within the buildings and on the site.
4. Clean up any oil spills observed in the parking lot, garages, or other surfaces in a timely manner.
5. Monitor all material deliveries.

6. Inspect all storage tanks prior to filling activities for spills, leaks and corrosion.

### **3.4 Spill Prevention and Response**

The following procedures apply to the facility:

- All personnel are instructed in location, use, and disposal of spill response equipment and supplies maintained at the site such as oil absorbent materials.
- The Pollution Prevention Team leader will be advised immediately of all spills of hazardous materials or regulated materials, regardless of quantity.
- Spills will be evaluated to determine the necessary response. If there is a health hazard, fire or explosion potential, 911 will be called. If a spill exceeds five gallons or threatens surface waters, including the storm drain system, state or federal emergency response agencies will be called.
- Spills will be contained as close to the source as possible with oil-absorbent materials. Additional materials or oil-absorbent socks will be utilized to protect adjacent catch basins.

## SECTION 4 – Plan Implementation

### 4.1 Employee Training

Regular employee training is required for employees who work in areas where materials or activities are exposed to stormwater, or who are responsible for implementing activities identified in the SWPPP, including all members of the Pollution Prevention Team.

The DPW is responsible for stormwater management training for DPW employees. This position coordinates training related to stormwater management on at least an annual basis to review specific responsibilities for implementing this SWPPP, what and how to accomplish those responsibilities, including BMP implementation.

Additionally, general awareness training is provided regularly (preferably annually) to all employees whose activities may impact stormwater discharges. The purpose of this training is to educate workers on activities that can impact stormwater discharges and to help implement BMPs.

All employees responsible for the fueling or lubrication of vehicles or equipment stored at the facility will be trained regularly (preferably annually). The topics below will be covered at employee training sessions.

1. Spill prevention and response.
2. Good housekeeping.
3. Materials management practices.

Pollution Prevention Team members will meet at least twice a year to discuss the effectiveness of and improvement to the SWPPP. **Appendix B** contains copies of training documentation from these training activities including attendance sheets, instructor name and affiliation, date, time, and location of the training.

### 4.2 Site Inspection Requirements

It is required that the entire DPW be inspected at least once each calendar quarter when the facility is in operation (at least one inspection must be conducted during a period when stormwater discharge is occurring). The Town Engineer is responsible for completing this inspection.

The inspection must check for evidence of pollution, evaluate non-structural controls in place at the site, and inspect equipment. The site inspection report must include:

- The inspection date and time
- The name of the inspector
- Weather information and a description of any discharge occurring at the time of the inspection

- Identification of any previously unidentified discharges from the site
- Any control measures needing maintenance or repair
- Any failed control measures that need replacement
- Any SWPPP changes required as a result of the inspection
- Signed certification statement.

The inspection form for these inspections, and copies of completed inspection forms, are included in **Appendix C**.

Corrective actions may be required based on evidence of past stormwater pollution or the high potential for future stormwater pollution to occur. Information about any issues and the respective corrective actions must be included in a Compliance Evaluation report. The permittee must repair or replace control measures in need of repair or replacement before the next anticipated storm event if possible, or as soon as practicable. In the interim, the permittee shall have back-up measures in place. The Compliance Evaluation report must be kept with the SWPPP and must state the problem, the solution, and when the solution was implemented.

### 4.3 Recordkeeping and Reporting

The permittee must keep a written record (hardcopy or electronic) of all activities required by the SWPPP including but not limited to maintenance, inspections, and training for a period of at least five years.

This SWPPP shall be kept at the DPW Offices building and shall be updated if any of the conditions in **SECTION 2.21** occur. The SWPPP and records shall be made available to state or federal inspectors and the general public upon request.

The 2016 Massachusetts MS4 Permit requires that each permittee report on the findings from Site Inspections in the annual report to USEPA and MassDEP.

Inspections of the DPW should be performed at least quarterly (at least one during stormwater discharge) and described in the Annual Report, including any corrective actions taken, to demonstrate that operation of the DPW is in compliance with the 2016 Massachusetts MS4 Permit.

### 4.4 Triggers for SWPPP Revisions

Town of Foxborough shall review this SWPPP regularly to determine if any update or revision is required. Changes that may trigger revision include:

- An increase in the quantity of any potential pollutant stored at the facility;
- The addition of any new potential pollutant (not already addressed in this SWPPP) to the list of materials stored or used at the facility;
- Physical changes to the facility that expose any potential pollutant (not presently exposed) to stormwater;

- Presence of a new authorized non-stormwater discharge at the facility; or
- Addition of an activity that introduces a new potential pollutant.

Changes in activity may include an expansion of operations, or changes in any significant material handling or storage practices which could impact stormwater.

The amended SWPPP will describe the new activities that could contribute to increased pollution, as well as control measures that have been implemented to minimize the potential for pollution.

This SWPPP will be amended if a state or federal inspector determines that it is not effective in controlling stormwater pollutants discharged to waterways.





# Locus Map - 70 Elm Street



70 Elm Street

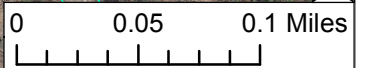



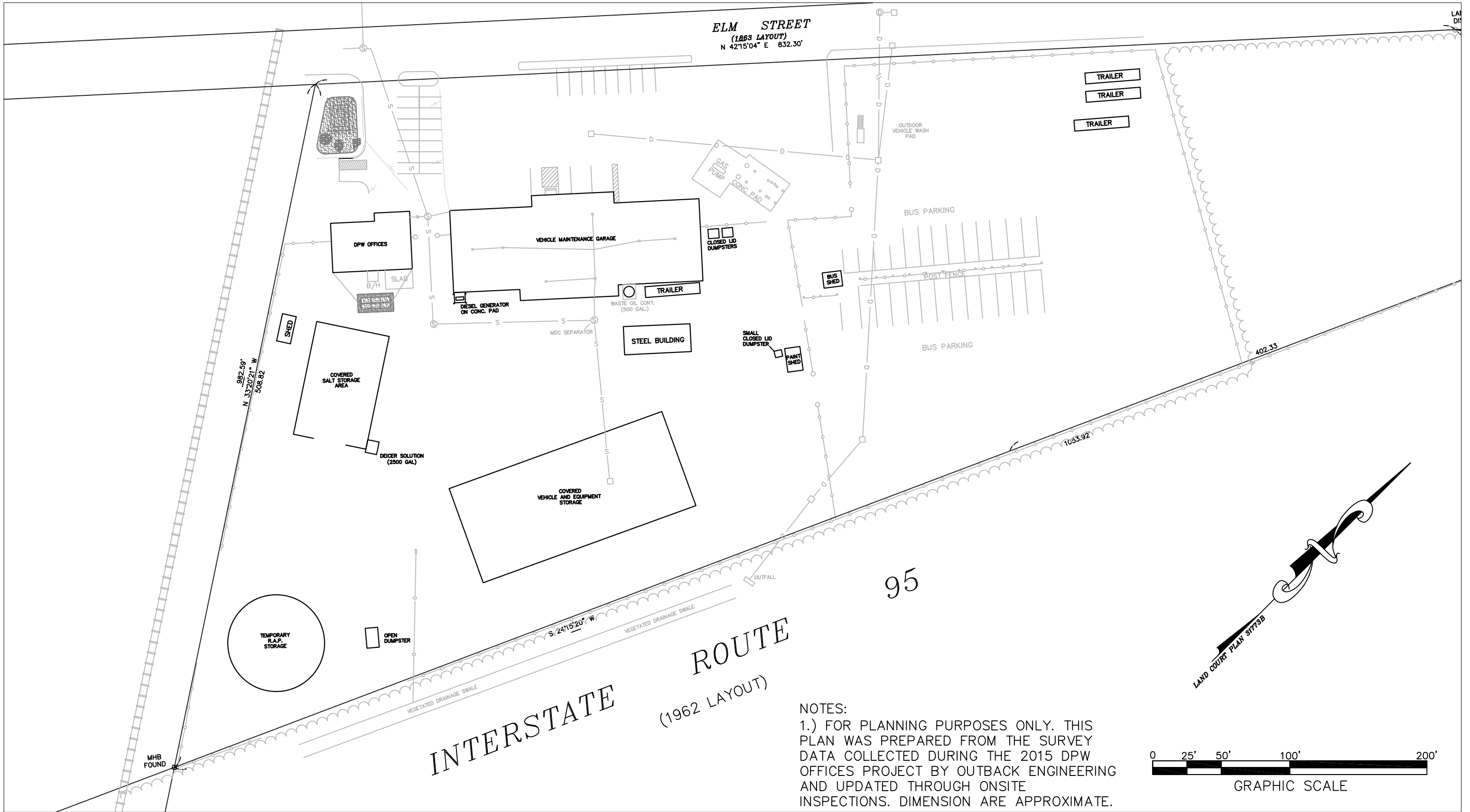

NOTES:  
 1.) FOR PLANNING PURPOSES ONLY. THIS PLAN WAS PREPARED FROM THE SURVEY DATA COLLECTED DURING THE 2015 DPW OFFICES PROJECT BY OUTBACK ENGINEERING AND UPDATED THROUGH ONSITE INSPECTIONS. DIMENSION ARE APPROXIMATE.

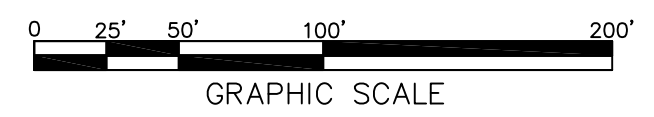

DRAWN BY: LD  
 DATE: 06/26/20  
 REVISION DATE; N/A

STORMWATER POLLUTION PREVENTION PLAN  
 SITE PLAN  
 DEPARTMENT OF PUBLIC WORKS  
 70 ELM STREET  
 TOWN OF FOXBOROUGH, MASSACHUSETTS

PREPARED BY:  
 TOWN OF FOXBOROUGH, MA  
 DEPARTMENT OF PUBLIC WORKS



## Significant Spills, Leaks or Other Releases

**Instructions:**

- Include the descriptions and dates of any incidences of significant spills, leaks, or other releases that resulted in discharges of pollutants to waters of the U.S., through stormwater or otherwise; the circumstances leading to the release and actions taken in response to the release; and measures taken to prevent the recurrence of such releases .
- Provide information, as shown below, for each incident, and attach additional documentation (e.g., photos, spill cleanup records) as necessary. Repeat as necessary by copying and pasting the fields below.

Date of incident: [Insert Date of Incident](#)

Location of incident: [Insert Location of Incident](#)

Description of incident: [Insert Description of Incident](#)

Circumstances leading to release: [Describe circumstances leading to release](#)

Actions taken in response to release: [Describe actions taken in response to release](#)

Measures taken to prevent recurrence: [Describe measures taken to prevent recurrence](#)

Date of incident: [Insert Date of Incident](#)

Location of incident: [Insert Location of Incident](#)

Description of incident: [Insert Description of Incident](#)

Circumstances leading to release: [Describe circumstances leading to release](#)

Actions taken in response to release: [Describe actions taken in response to release](#)

Measures taken to prevent recurrence: [Describe measures taken to prevent recurrence](#)

Date of incident: [Insert Date of Incident](#)

Location of incident: [Insert Location of Incident](#)

Description of incident: [Insert Description of Incident](#)

Circumstances leading to release: [Describe circumstances leading to release](#)

Actions taken in response to release: [Describe actions taken in response to release](#)

Measures taken to prevent recurrence: [Describe measures taken to prevent recurrence](#)

Date of incident: [Insert Date of Incident](#)

Location of incident: [Insert Location of Incident](#)

Description of incident: [Insert Description of Incident](#)

Circumstances leading to release: [Describe circumstances leading to release](#)

Actions taken in response to release: [Describe actions taken in response to release](#)

Measures taken to prevent recurrence: [Describe measures taken to prevent recurrence](#)



Massachusetts  
Department  
of  
ENVIRONMENTAL  
PROTECTION

# fact sheet

## Managing spills of oil and hazardous materials

### Information for municipalities

#### Purpose

Oil or chemical spill responses are local events. Because timely action is critical to the success of any cleanup, the Massachusetts Department of Environmental Protection (MassDEP) has prepared this guide to help municipal officials:

- Take defensive action at all spills to identify receptors and limit/contain the release
- After relevant training, take proactive actions to control and clean up spills of limited scope
- Provide support, in accordance with the Incident Management System, to the Fire Department, which normally is the lead agency in spill response situations
- Determine when MassDEP or a Licensed Site Professional (LSP) needs to lead a cleanup
- Represent the municipality's interests in cleanup decisions

#### Who must clean up a spill?

The primary responsibility for hiring contractors for on-site cleanup and disposal of waste materials, including all associated costs, rests with the person or party that causes or contributes to the release and/or with the owner of the property where it happens. They are collectively referred to as Potentially Responsible Parties (PRPs).<sup>1</sup>



*Methuen Fire Department response to liquid asphalt spill. Photo by Steven Ross, MassDEP.*

<sup>1</sup> M.G.L. Chapter 21E (the Massachusetts Oil and Hazardous Material Release Prevention Act) and 310 CMR 40.0000 (the Massachusetts Contingency Plan, or MCP) spell out the procedures and requirements for release notification, spill response and the cleanup standards that must be met.

Massachusetts Department of  
Environmental Protection  
One Winter Street  
Boston, MA 02108-4746

Commonwealth of Massachusetts  
Mitt Romney, Governor  
Kerry Healey, Lt. Governor

Executive Office of  
Environmental Affairs  
Stephen R. Pritchard, Secretary

Department of  
Environmental Protection  
Robert W. Gollodge, Jr.,  
Commissioner

Produced by the  
Bureau of Waste Site Cleanup,  
2/01, rev. 4/04, 4/06  
Printed on recycled paper

This information is available in  
alternate format by calling our ADA  
Coordinator at  
(617) 56-1057.



## Does the size, type, or location of a spill make a difference?

Yes. Depending on the size and type of spill, MassDEP and other local, state, and federal agencies may have a role in spill response. The PRP must report spills to MassDEP if they exceed specific thresholds. Some releases are exempt from reporting requirements under the MCP. These are spills that involve:

- less than 10 gallons of petroleum and which does not impact a waterbody
- less than one pound of hazardous chemicals and which does not pose an imminent hazard
- fuel from passenger vehicle accidents or
- a vault or building with a watertight floor and with walls that completely contain all released chemicals

Regardless of whether MassDEP notification is required, all spills of oil and hazardous materials must be cleaned up to the extent that no risk to human health is present.

## Who responds to oil and hazardous material releases of a limited scope?

The fire department normally responds to spills, initiates containment, and usually directs cleanup of spills of limited scope, i.e. those that do not trigger MassDEP reporting thresholds. When the PRP is unable or unwilling to take responsibility, the fire department may also arrange for cleanup, either by hiring an outside contractor or by using in-house resources. The municipal public works department or other local agencies sometimes provide support. MassDEP generally does not respond to non-reportable releases or those of limited scope, but will be available for technical support. MassDEP will always respond to larger and more complicated spills with potential for posing imminent health, safety, or environmental hazards. MassDEP also attempts to respond to releases where public safety officials request assistance in directing the cleanup.

## What specific roles do local officials play?

First responders to a spill are usually equipped to take some action to contain it. Containment is critical to protecting resources at risk. For example, the fire department might take measures to stop the flow or contain the release with absorbents, while public works personnel deliver and spread sand, pick up debris, and provide street drainage maps to aid in the spill investigation. Some municipalities have one or more environmental cleanup firm on retainer to help deal with responses to spills of limited scope.

When PRPs are unable or unwilling to respond, a statewide comprehensive "Hazardous Materials and Medical Waste Collection and Disposal" (FAC36) contract can be used by towns, cities, and state agencies to hire cleanup companies. The contract also provides for emergency response preparedness training for government workers. The contract establishes "Not to Exceed" rates for labor, transportation, and oil and hazardous materials disposal. Information about the Comm-PASS contract may be found at the web site of the Massachusetts Operational Services Division at [www.mass.gov/osd](http://www.mass.gov/osd).

## What training is necessary for cleanup workers?

Because of their roles as first responders and the associated risks of direct exposure to hazardous chemicals, fire department personnel typically undergo training to deal with petroleum and chemical releases, as described in OSHA 1910.120. The International Association of Fire Fighters and the Massachusetts Firefighting Academy offer training programs.

Basic awareness training is highly recommended for staff from other municipal agencies who may be at less risk of direct exposure but still play critical support roles.

## How do wastes from spill cleanups need to be handled?

Sand and absorbents contaminated with petroleum can be reused, disposed, or otherwise handled as described in MassDEP policy WSC-94-400, Interim Remediation Waste Management Policy for Petroleum Contaminated Soils, [www.mass.gov/dep/images/wsc94400.pdf](http://www.mass.gov/dep/images/wsc94400.pdf). But sand and absorbents that are saturated

with petroleum products or by other hazardous chemicals may need special handling (disposal) by licensed transporters. Depending on the size and severity of a spill, a Licensed Site Professional (LSP) may also need to be hired to oversee the cleanup and sign-off on the disposal. MassDEP requires municipalities to properly manage and store small quantities of hazardous materials from spill cleanups. If storage that is consistent with MassDEP guidelines is not possible, an environmental waste removal firm should be hired to remove the material.

#### Contacting MassDEP Regional Offices:

Northeast Regional Office – 205B Lowell Street, Wilmington, Massachusetts 01887

<http://www.mass.gov/dep/about/region/northeast.htm> (978) 694-3200

Southeast Regional Office - 20 Riverside Dr., Lakeville, MA 02347

<http://www.mass.gov/dep/about/region/southeast.htm> (508) 946-2700

Central Regional Office - 627 Main St., Worcester, MA 01608

<http://www.mass.gov/dep/about/region/centralr.htm> (508) 792-7650

Western Regional Office - 436 Dwight St., Springfield, MA 01103

<http://www.mass.gov/dep/about/region/westernr.htm> (413) 784-1100

Visit <http://www.mass.gov/dep/about/region/findyour.htm> to determine which MassDEP regional office serves your community.

#### For more information:

- If you have questions, please email MassDEP at [BWSC.Information@state.ma.us](mailto:BWSC.Information@state.ma.us).
- For copies of MassDEP regulations, policies, and other publications, visit: <http://www.mass.gov/dep/bwsc/pubs.htm>

#### Related regulations and guidance documents:

- Interim Remediation Waste Management Policy for Petroleum Contaminated Soil, WSC-94-400, [www.mass.gov/dep/images/wsc94400.pdf](http://www.mass.gov/dep/images/wsc94400.pdf)
- Reuse and Disposal of Contaminated Soil at Massachusetts Landfills, COMM-97-001, <http://www.mass.gov/dep/recycle/laws/97-001.htm>
- Characteristics of Hazardous Waste, 310 CMR 30.120, <http://www.mass.gov/dep/service/regulations/310cmr30.pdf>
- A Summary of Requirements for Small Quantity Generators, <http://www.mass.gov/dep/recycle/laws/sqgsum.pdf>

#### MassDEP Telephone numbers:

- Hazardous Waste Compliance Assistance Line – (617) 292-5898
- Household Hazardous Products Hotline – (800) 343-3420

#### Above ground or underground storage tanks:

Call the local fire department or the Massachusetts Department of Fire Services at (978) 567-3100 or 413-587-3181.

#### LSP information:

Visit the LSP Board's web page at <http://www.mass.gov/lsp> or call (617) 556-1091.

---

## MassDEP 24-hour Spill Reporting

### To report a release of oil or hazardous materials, and other environmental emergencies, call the MassDEP 24-hour notification line toll-free at

# (888) 304-1133

Massachusetts Department of  
Environmental Protection  
One Winter Street  
Boston, MA 02108-4746

Commonwealth of Massachusetts  
Mitt Romney, Governor  
Kerry Healey, Lt. Governor

Executive Office of  
Environmental Affairs  
Stephen R. Pritchard, Secretary

Department of  
Environmental Protection  
Robert W. Gollodge, Jr.,  
Commissioner

Produced by the  
Bureau of Waste Site Cleanup,  
2/01, rev. 4/04, 4/06  
Printed on recycled paper

This information is available in  
alternate format by calling our ADA  
Coordinator at  
(617) 56-1057.





## Employee Training

<p><b>Instructions:</b></p> <ul style="list-style-type: none"> <li>– Keep records of employee training, including the date of the training.</li> <li>– For in-person training, consider using the tables below to document your employee trainings. For computer-based or other types of training, keep similar records on who was trained and the type of training conducted.</li> </ul>
---

Training Date: <a href="#">Insert Date of Training</a>	
Training Description (including duration and subjects covered): <a href="#">Insert Description of Training</a>	
Trainer: <a href="#">Insert Trainer(s) names</a>	
Employee(s) trained	Employee signature
<a href="#">Insert Name</a>	
<a href="#">Insert Name</a>	
<a href="#">Insert Name</a>	
<a href="#">Insert Name</a>	
<a href="#">Insert Name</a>	
<a href="#">Insert Name</a>	

Training Date: <a href="#">Insert Date of Training</a>	
Training Description (including duration and subjects covered): <a href="#">Insert Description of Training</a>	
Trainer: <a href="#">Insert Trainer(s) names</a>	
Employee(s) trained	Employee signature
<a href="#">Insert Name</a>	
<a href="#">Insert Name</a>	
<a href="#">Insert Name</a>	
<a href="#">Insert Name</a>	
<a href="#">Insert Name</a>	
<a href="#">Insert Name</a>	

Training Date: <a href="#">Insert Date of Training</a>	
Training Description (including duration and subjects covered): <a href="#">Insert Description of Training</a>	
Trainer: <a href="#">Insert Trainer(s) names</a>	
Employee(s) trained	Employee signature
<a href="#">Insert Name</a>	
<a href="#">Insert Name</a>	
<a href="#">Insert Name</a>	
<a href="#">Insert Name</a>	
<a href="#">Insert Name</a>	
<a href="#">Insert Name</a>	

## Site Inspection Reports

### Instructions:

- Include in your records copies of all routine facility inspection reports completed for the facility.
- The sample inspection report is consistent with the requirements in the 2016 Massachusetts MS4 Permit relating to site inspections. If MassDEP provides you with an inspection report, use that form.

### Using the Sample Site Inspection Report

- This inspection report is designed to be customized according to the specific control measures and activities at your facility. For ease of use, you should take a copy of your site plan and number all of the stormwater control measures and areas of industrial activity that will be inspected. A brief description of the control measures and areas that were inspected should then be listed in the site-specific section of the inspection report.
- You can complete the items in the “General Information” section that will remain constant, such as the facility name and inspector (if you only use one inspector). Print out multiple copies of this customized inspection report to use during your inspections.
- When conducting the inspection, walk the site by following your site map and numbered control measures/areas of industrial activity to be inspected. Also note whether the “Areas of Materials or Activities exposed to stormwater” have been addressed (customize this list according to the conditions at your facility). Note any required corrective actions and the date and responsible person for the correction.



## Stormwater Site Inspection Report

General Information			
Facility Name	Insert Name		
Date of Inspection	Insert Date	Start/End Time	Insert Start/End Time
Inspector's Name(s)	Insert Name		
Inspector's Title(s)	Insert Title		
Inspector's Contact Information	Insert Contact Info		
Inspector's Qualifications	Insert qualifications or add reference to the SWPPP		
Weather Information			
Weather at time of this inspection? <input type="checkbox"/> Clear <input type="checkbox"/> Cloudy <input type="checkbox"/> Rain <input type="checkbox"/> Sleet <input type="checkbox"/> Fog <input type="checkbox"/> Snow <input type="checkbox"/> High Winds <input type="checkbox"/> Other: _____                      Temperature: _____			
Have any previously unidentified discharges of pollutants occurred since the last inspection? <input type="checkbox"/> Yes <input type="checkbox"/> No If yes, describe: <a href="#">Describe</a>			
Are there any discharges occurring at the time of inspection? <input type="checkbox"/> Yes <input type="checkbox"/> No If yes, describe: <a href="#">Describe</a>			

**Control Measures**

- Number the structural stormwater control measures identified in your SWPPP on your site map and list them below (add as many control measures as are implemented on-site). Carry a copy of the numbered site map with you during your inspections. This list will ensure that you are inspecting all required control measures at your facility.
- Describe corrective actions initiated, date completed, and note the person that completed the work in the Corrective Action Log.

	Structural Control Measure	Control Measure is Operating Effectively?	If No, In Need of Maintenance, Repair, or Replacement?	Corrective Action Needed and Notes (identify needed maintenance and repairs, or any failed control measures that need replacement)
1	Insert Control Measure Name	<input type="checkbox"/> Yes <input type="checkbox"/> No	<input type="checkbox"/> Maintenance <input type="checkbox"/> Repair <input type="checkbox"/> Replacement	<a href="#">Describe Corrective Actions</a>
2	Insert Control Measure Name	<input type="checkbox"/> Yes <input type="checkbox"/> No	<input type="checkbox"/> Maintenance <input type="checkbox"/> Repair <input type="checkbox"/> Replacement	<a href="#">Describe Corrective Actions</a>
3	Insert Control Measure Name	<input type="checkbox"/> Yes <input type="checkbox"/> No	<input type="checkbox"/> Maintenance <input type="checkbox"/> Repair <input type="checkbox"/> Replacement	<a href="#">Describe Corrective Actions</a>
4	Insert Control Measure Name	<input type="checkbox"/> Yes <input type="checkbox"/> No	<input type="checkbox"/> Maintenance <input type="checkbox"/> Repair <input type="checkbox"/> Replacement	<a href="#">Describe Corrective Actions</a>
5	Insert Control Measure Name	<input type="checkbox"/> Yes <input type="checkbox"/> No	<input type="checkbox"/> Maintenance <input type="checkbox"/> Repair <input type="checkbox"/> Replacement	<a href="#">Describe Corrective Actions</a>
6	Insert Control Measure Name	<input type="checkbox"/> Yes <input type="checkbox"/> No	<input type="checkbox"/> Maintenance <input type="checkbox"/> Repair <input type="checkbox"/> Replacement	<a href="#">Describe Corrective Actions</a>
7	Insert Control Measure Name	<input type="checkbox"/> Yes <input type="checkbox"/> No	<input type="checkbox"/> Maintenance	<a href="#">Describe Corrective Actions</a>

	Structural Control Measure	Control Measure is Operating Effectively?	If No, In Need of Maintenance, Repair, or Replacement?	Corrective Action Needed and Notes (identify needed maintenance and repairs, or any failed control measures that need replacement)
	Name		<input type="checkbox"/> Repair <input type="checkbox"/> Replacement	
8	Insert Control Measure Name	<input type="checkbox"/> Yes <input type="checkbox"/> No	<input type="checkbox"/> Maintenance <input type="checkbox"/> Repair <input type="checkbox"/> Replacement	Describe Corrective Actions
9	Insert Control Measure Name	<input type="checkbox"/> Yes <input type="checkbox"/> No	<input type="checkbox"/> Maintenance <input type="checkbox"/> Repair <input type="checkbox"/> Replacement	Describe Corrective Actions
10	Insert Control Measure Name	<input type="checkbox"/> Yes <input type="checkbox"/> No	<input type="checkbox"/> Maintenance <input type="checkbox"/> Repair <input type="checkbox"/> Replacement	Describe Corrective Actions

**Areas of Materials or Activities exposed to stormwater**

Below are some general areas that should be assessed during routine inspections. Customize this list as needed for the specific types of materials or activities at your facility.

	Area/Activity	Inspected?	Controls Adequate (appropriate, effective, and operating)?	Corrective Action Needed and Notes
1	Material loading/unloading and storage areas	<input type="checkbox"/> Yes <input type="checkbox"/> No <input type="checkbox"/> N/A	<input type="checkbox"/> Yes <input type="checkbox"/> No	Describe Corrective Actions
2	Equipment operations and maintenance areas	<input type="checkbox"/> Yes <input type="checkbox"/> No <input type="checkbox"/> N/A	<input type="checkbox"/> Yes <input type="checkbox"/> No	Describe Corrective Actions
3	Fueling areas	<input type="checkbox"/> Yes <input type="checkbox"/> No <input type="checkbox"/> N/A	<input type="checkbox"/> Yes <input type="checkbox"/> No	Describe Corrective Actions
4	Outdoor vehicle and equipment washing areas	<input type="checkbox"/> Yes <input type="checkbox"/> No <input type="checkbox"/> N/A	<input type="checkbox"/> Yes <input type="checkbox"/> No	Describe Corrective Actions
5	Waste handling and disposal areas	<input type="checkbox"/> Yes <input type="checkbox"/> No <input type="checkbox"/> N/A	<input type="checkbox"/> Yes <input type="checkbox"/> No	Describe Corrective Actions
6	Erodible areas/construction	<input type="checkbox"/> Yes <input type="checkbox"/> No <input type="checkbox"/> N/A	<input type="checkbox"/> Yes <input type="checkbox"/> No	Describe Corrective Actions
7	Non-stormwater/ illicit connections	<input type="checkbox"/> Yes <input type="checkbox"/> No <input type="checkbox"/> N/A	<input type="checkbox"/> Yes <input type="checkbox"/> No	Describe Corrective Actions
8	Salt storage piles or pile containing salt	<input type="checkbox"/> Yes <input type="checkbox"/> No <input type="checkbox"/> N/A	<input type="checkbox"/> Yes <input type="checkbox"/> No	Describe Corrective Actions
9	Dust generation and vehicle tracking	<input type="checkbox"/> Yes <input type="checkbox"/> No <input type="checkbox"/> N/A	<input type="checkbox"/> Yes <input type="checkbox"/> No	Describe Corrective Actions
10	(Other)	<input type="checkbox"/> Yes <input type="checkbox"/> No <input type="checkbox"/> N/A	<input type="checkbox"/> Yes <input type="checkbox"/> No	Describe Corrective Actions

	Area/Activity	Inspected?	Controls Adequate (appropriate, effective, and operating)?	Corrective Action Needed and Notes
11	(Other)	<input type="checkbox"/> Yes <input type="checkbox"/> No <input type="checkbox"/> N/A	<input type="checkbox"/> Yes <input type="checkbox"/> No	<a href="#">Describe Corrective Actions</a>
12	(Other)	<input type="checkbox"/> Yes <input type="checkbox"/> No <input type="checkbox"/> N/A	<input type="checkbox"/> Yes <input type="checkbox"/> No	<a href="#">Describe Corrective Actions</a>

**Non-Compliance**

Describe any incidents of non-compliance observed and not described above:  
[Describe Non-compliance](#)

**Additional Control Measures**

Describe any additional control measures or changes to the SWPPP needed to comply with the permit requirements:  
[Describe Additional Controls Needed](#)

**Notes**

Use this space for any additional notes or observations from the inspection:  
[Additional Notes](#)

**Print inspector name and title:**

\_\_\_\_\_

**Signature:** \_\_\_\_\_ **Date:** \_\_\_\_\_

## Quarterly Visual Assessment Reports – additional form when stormwater discharge is occurring

**Instructions:**

- Include in your records copies of all quarterly visual assessment reports completed for the facility. An example quarterly visual assessment report can be found on the following page.
- At least one quarterly inspection per year must occur while stormwater is discharging.

Quarterly Visual Assessment Form– additional form when stormwater discharge is occurring

(Complete a separate form for each outfall you assess)

Name of Facility: Name of Facility

Outfall Name: Name "Substantially Identical Outfall"?  No  Yes (identify substantially identical outfalls):

Person(s)/Title(s) collecting sample: Name/Title

Person(s)/Title(s) examining sample: Name/Title

Date & Time Discharge Began (approx.):  
Enter date and time

Date & Time Visual Sample Collected:  
Enter date and time

Date & Time Visual Sample Examined:  
Enter date and time

Nature of Discharge:  Rainfall  Snowmelt

Parameter

Color  None  Other (describe):

Odor  None  Musty  Sewage  Sulfur  Sour  Petroleum/Gas \_\_\_\_\_  
 Solvents  Other (describe):

Clarity  Clear  Slightly Cloudy  Cloudy  Opaque  Other

Floating Solids  No  Yes (describe):

Settled Solids\*  No  Yes (describe):

Suspended Solids  No  Yes (describe):

Foam (gently shake sample)  No  Yes (describe):

Oil Sheen  None  Flecks  Globs  Sheen  Slick  
 Other (describe):

Other Obvious Indicators  No  Yes (describe):  
of Stormwater Pollution

\* Observe for settled solids after allowing the sample to sit for approximately one-half hour.

Detail any concerns, additional comments, descriptions of pictures taken, and any corrective actions taken below (attach additional sheets as necessary). Insert details

A. Name:

B. Title:

C. Signature:

D. Date Signed:

## **Appendix I**

# **Dry Weather Outfall Inspection Results**

Town of Foxborough, MA  
FY21 Outfall Inspections

Point_ID	DOI	INSPECTOR	DIAMETER	DIRECTION	FLOW	MATERIAL	ODOR	Point_Code	AU_ID	IMAGE	END_SHAPE	CONDITION	SUBMERGED	ODOR_COMM/COLOR	COLOR_COMM	OTHER_MATE	SHOEN	SHOEN_COMM	TURBIDITY	TURBIDITY	FLOATABLES	FLOATAB_L	OTHER_SHAP	NOTES	GlobalID	x	y	Flow	OBJECTID_1	OBJECTID_2	OBJECTID
19-04	2020-11-11	LD	22 IN		DRY	CONCRETE	NO	OUTFALL	MA62-47	W\DPW\GIS\UROUND	FAIR	NO	NO	NO	NO		NO	NO	NO	NO	NO	NO		ae07df3a8-cd98	-71.27892373	42.03513166	86	86	86	132	
08-16	2020-11-10	LD	27 IN		DRY	CORRUGATED METAL	NO	OUTFALL			POOR	YES	NO	NO	NO		NO	NO	NO	NO	NO	NO		ae400a8d-95ff	-71.24801674	42.07977778	225	225	225	325	
08-04	2020-11-10	LD	24 IN	OUT	DRY	CONCRETE	NO	OUTFALL	MA73034	W\DPW\GIS\UROUND	GOOD	NO	NO	NO	NO		NO	NO	NO	NO	NO	NO		d1a2e055-8dfe	-71.25140806	42.07539485	119	119	119	184	
04-02	2020-11-10	LD	12 IN	OUT	DRY	CONCRETE	NO	OUTFALL	MA62-47	W\DPW\GIS\UROUND	GOOD	NO	NO	NO	NO		NO	NO	NO	NO	NO	NO		153e240b-e702	-71.27936742	42.08312175	132	132	132	207	
04-01	2020-11-10	LD	21 IN	OUT	DRY	CONCRETE	NO	OUTFALL	MA62-47	W\DPW\GIS\UROUND	GOOD	NO	NO	NO	NO		NO	NO	NO	NO	NO	NO		d357ea58-f34a	-71.27936133	42.08312958	131	131	131	206	
02-12	2020-11-10	LD	12 IN	OUT	DRY	CONCRETE	NO	OUTFALL			ROUND	GOOD	NO	NO	NO		NO	NO	NO	NO	NO	NO		3459b406-16f7	-71.25487099	42.09790638	220	220	220	319	
02-02	2020-11-10	LD	12 IN	OUT	DRY	CONCRETE	NONE	OUTFALL	MA73-01	W\DPW\GIS\Utilities\Drain\Images\img_BEACH ST 11_080615_195159.jpg														91fbc854-279c	-71.25576302	42.09912333	137	137	137	214	
16-06	2020-11-09	LD	24 IN	OUT	DRY	CONCRETE	NO	OUTFALL	MA62-47	W\DPW\GIS\UROUND	GOOD	YES	NO	NO	NO		NO	NO	NO	NO	NO	NO		5c7f70d9-4a75	-71.25755664	42.05293865	58	58	58	91	
12-05	2020-11-09	LD	8 IN	OUT	DRY	PVC	NO	OUTFALL	MA62-47	W\DPW\GIS\UROUND	GOOD	NO	NO	NO	NO		NO	NO	NO	NO	NO	NO		9862813-4928	-71.25824195	42.0588901	92	92	92	141	
12-04	2020-11-09	LD	8 IN	OUT	DRY	PVC	NO	OUTFALL	MA62-47	W\DPW\GIS\UROUND	GOOD	NO	NO	NO	NO		NO	NO	NO	NO	NO	NO		89c1c21-0b07	-71.25916777	42.05565046	89	89	89	135	
02-08	2020-11-09	LD	24 IN	OUT	HEAVY	CORRUGATED METAL	NO	OUTFALL	MA73-01	106_1	ROUND	CRUMBLING	NO	NO	NO		NO	NO	NO	NO	NO	NO		a4e756e1-08d1	-71.26047282	42.09790439	171	171	171	264	
02-07	2020-11-09	LD	12 IN	OUT	DRY	CONCRETE	NO	OUTFALL	MA73-01	102_1	ROUND	FAIR	NO	NO	NO		NO	NO	NO	NO	NO	NO		04a3f5db-f717	-71.26090597	42.0969355	170	170	170	263	
15-08	2020-11-06	LD	15 IN		DRY	CONCRETE	NO	OUTFALL			ROUND	GOOD	NO	NO	NO		NO	NO	NO	NO	NO	NO		406b7f02-ee5c	-71.2885242	42.04488981	264	264	264	366	
15-07	2020-11-06	LD	15 IN		DRY	CONCRETE	NO	OUTFALL			ROUND	GOOD	NO	NO	NO		NO	NO	NO	NO	NO	NO		0fcb8f4f-63bb	-71.2888448	42.04517822	263	263	263	365	
15-06	2020-11-06	LD	12 IN		DRY	CONCRETE	NO	OUTFALL			ROUND	GOOD	NO	NO	NO		NO	NO	NO	NO	NO	NO		7e54aec2-6c5e	-71.27280508	42.04381687	212	212	212	311	
15-05	2020-11-06	LD	12 IN		DRY	CONCRETE	NO	OUTFALL			ROUND	GOOD	NO	NO	NO		NO	NO	NO	NO	NO	NO		ab0331e7-c5cd	-71.27284237	42.04377147	211	211	211	310	
15-04	2020-11-06	LD	12 IN		DRY	OTHER	NO	OUTFALL			ROUND	FAIR	NO	NO	NO		NO	NO	NO	NO	NO	NO		af38ec00-7872	-71.27541956	42.04213665	210	210	210	309	
15-03	2020-11-06	LD	24 IN	OUT	TRICKLING	CONCRETE	NO	OUTFALL	MA62-47	W\DPW\GIS\UROUND	GOOD	NO	NO	NO	NO		NO	NO	NO	NO	NO	NO		a05f133e-8622	-71.28362997	42.04592923	85	85	85	131	
15-02	2020-11-06	LD	10 IN	OUT	TRICKLING	CONCRETE	NO	OUTFALL	MA62-47	W\DPW\GIS\UROUND	FAIR	YES	NO	NO	NO		NO	NO	NO	NO	NO	NO		71c72f56-3797	-71.27166653	42.04906195	82	82	82	123	
15-01	2020-11-06	LD	10 IN	OUT	TRICKLING	CONCRETE	NO	OUTFALL	MA62-47	W\DPW\GIS\UROUND	GOOD	NO	NO	NO	NO		NO	NO	NO	NO	NO	NO		d6e695cc-2495	-71.26185591	42.04927885	81	81	81	119	
N/A	2020-11-06	RN	12 IN		HEAVY	CONCRETE	NO	OUTFALL			ROUND	GOOD	NO	NO	NO		NO	NO	NO	NO	NO	NO		760ca49-190c	-71.20005959	42.05946698	284	284	0	0	
N/A	2020-11-06	RN	24 IN		MODERATE	CONCRETE	NO	OUTFALL			ROUND	GOOD	YES	NO	NO		NO	NO	NO	NO	NO	NO		03fa38b2-5c1b	-71.24524893	42.10527746	283	283	0	0	
20-35	2020-11-05	RN	12 IN		DRY	CONCRETE	NO	OUTFALL			ROUND	GOOD	NO	NO	NO		NO	NO	NO	NO	NO	NO		5276f20b-ba98	-71.2601957	42.03414901	249	249	249	351	
20-34	2020-11-05	RN	18 IN		DRY	CONCRETE	NO	OUTFALL			ROUND	GOOD	NO	NO	NO		NO	NO	NO	NO	NO	NO		3a66ef6a-6c32	-71.2538707	42.03108725	248	248	248	350	
20-33	2020-11-05	RN	12 IN		DRY	CONCRETE	NO	OUTFALL			ROUND	GOOD	NO	NO	NO		NO	NO	NO	NO	NO	NO		97b7395a-f7d0	-71.25542675	42.03262198	247	247	247	349	
20-32	2020-11-05	RN	15 IN		DRY	CONCRETE	NO	OUTFALL			ROUND	GOOD	NO	NO	NO		NO	NO	NO	NO	NO	NO		1647b0ea-b5d1	-71.2538102	42.03370941	246	246	246	348	
20-31	2020-11-05	RN	12 IN		DRY	CONCRETE	NO	OUTFALL			ROUND	GOOD	NO	NO	NO		NO	NO	NO	NO	NO	NO		237d9c5b-7933	-71.25278099	42.03264143	245	245	245	347	
20-30	2020-11-05	RN	12 IN		DRY	CONCRETE	NO	OUTFALL			ROUND	GOOD	NO	NO	NO		NO	NO	NO	NO	NO	NO		99249a98-ec8b	-71.25276885	42.03264418	244	244	244	346	
20-29	2020-11-05	RN	12 IN		DRY	CONCRETE	NO	OUTFALL			ROUND	GOOD	NO	NO	NO		NO	NO	NO	NO	NO	NO		0f04689-62c6	-71.24804722	42.04998784	215	215	215	314	
20-28	2020-11-05	RN	15 IN	OUT	DRY	CONCRETE	NO	OUTFALL	MA62-47	W\DPW\GIS\UROUND	GOOD	NO	NO	NO	NO		NO	NO	NO	NO	NO	NO		ebc46a9e-5d58	-71.26136734	42.03785593	164	164	164	257	
20-24	2020-11-05	RN	18 IN	OUT	DRY	CONCRETE	NO	OUTFALL	MA62-47	W\DPW\GIS\UROUND	GOOD	NO	NO	NO	NO		NO	NO	NO	NO	NO	NO		903d70e6-1851	-71.26020674	42.03094302	121	121	121	186	
20-23	2020-11-05	RN	12 IN	OUT	DRY	CONCRETE	NO	OUTFALL	MA62-47	W\DPW\GIS\UROUND	GOOD	NO	NO	NO	NO		NO	NO	NO	NO	NO	NO		4cba29e5-c597	-71.25193255	42.03370611	79	79	79	114	
20-22	2020-11-05	RN	4 IN	OUT	DRY	PVC	NO	OUTFALL	Not Outfall	W\DPW\GIS\UROUND	GOOD	NO	NO	NO	NO		NO	NO	NO	NO	NO	NO		779df2e4-2666	-71.25268419	42.03353946	78	78	78	113	
20-21	2020-11-05	RN	4 IN	OUT	DRY	PVC	NO	OUTFALL	Not Outfall	W\DPW\GIS\UROUND	GOOD	NO	NO	NO	NO		NO	NO	NO	NO	NO	NO		0d81246a-1f07	-71.25268156	42.03352999	77	77	77	112	
20-20	2020-11-05	RN	4 IN	OUT	DRY	PVC	NO	OUTFALL	Not Outfall	W\DPW\GIS\UROUND	GOOD	NO	NO	NO	NO		NO	NO	NO	NO	NO	NO		80998ad-3951	-71.25267968	42.03352403	76	76	76	111	
20-19	2020-11-05	RN	12 IN	OUT	DRY	CONCRETE	NO	OUTFALL	MA62-47	W\DPW\GIS\UROUND	GOOD	NO	NO	NO	NO		NO	NO	NO	NO	NO	NO		2dede405-28d4	-71.25263049	42.0335265	75	75	75	110	
20-18	2020-11-05	RN	6 IN	OUT	MODERATE	PVC	NO	OUTFALL	MA62-47	W\DPW\GIS\UROUND	GOOD	NO	NO	NO	NO		NO	NO	NO	NO	NO	NO		9bca2ea7-5bcd	-71.25297864	42.03355888	74	74	74	109	
20-17	2020-11-05	RN	18 IN	OUT	TRICKLING	CONCRETE	NO	OUTFALL	MA62-47	W\DPW\GIS\UROUND	GOOD	NO	NO	NO	NO		NO	NO	NO	NO	NO	NO		10c77a6f-ba3e	-71.26099771	42.03492888	71	71	71	106	
20-16	2020-11-05	RN	24 IN	OUT	DRY	CONCRETE	NO	OUTFALL	MA62-47	W\DPW\GIS\UROUND	GOOD	NO	NO	NO	NO		NO	NO	NO	NO	NO	NO		76955570-0347	-71.25573486	42.03412883	70	70	70	105	
20-15	2020-11-05	RN	12 IN	OUT	DRY	CONCRETE	NO	OUTFALL	MA62-47	W\DPW\GIS\UROUND	GOOD	NO	NO	NO	NO		NO	NO	NO	NO	NO	NO		22b3d003-58aa	-71.25587679	42.03266311	69	69	69	104	
20-14	2020-11-05	RN	12 IN	OUT	DRY	CONCRETE	NO	OUTFALL	MA62-47	W\DPW\GIS\UROUND	GOOD	NO	NO	NO	NO		NO	NO	NO	NO	NO	NO		dfc64bd7-f297	-71.25569704	42.03259965	68	68	68	103	
20-13	2020-11-05	RN	12 IN	OUT	DRY	CONCRETE	NO	OUTFALL	MA62-47	W\DPW\GIS\UROUND	GOOD	NO	NO	NO	NO		NO	NO	NO	NO	NO	NO		2197254d-a5c3	-71.25306051	42.03306208	67	67	67	102	
20-12	2020-11-05	RN	12 IN	OUT	DRY	CONCRETE	NO	OUTFALL	MA62-47	W\DPW\GIS\UROUND	GOOD																				



Town of Foxborough, MA  
FY21 Outfall Inspections

Point_ID	DOI	INSPECTOR	DIAMETER	DIRECTION	FLOW	MATERIAL	ODOR	Point_Code	AU_ID	IMAGE	END_SHAPE	CONDITION	SUBMERGED	ODOR_COMM	COLOR_COMM	OTHER_MATE	SHOEN	SHOEN_COMM	TURBIDITY	TURBIDITY	FLOATABLES	FLOATAB_L	OTHER_SHAP	NOTES	GlobalID	x	y	FD	OBJECTID_1	OBJECTID_2	OBJECTID
18-08	2020-10-26	RN	27 IN	OUT	DRY	CONCRETE	NO	OUTFALL	MA62-27	W\DPW\GIS\UROUND	ROUND	GOOD	NO	NO	NO	NO	NO	NO	NO	NO	NO	NO	NO	NO	ec01b778-d128	-71.1912391	42.05485851	35	35	48	
18-07	2020-10-26	RN	36 IN	OUT	DRY	CONCRETE	NO	OUTFALL	MA62-27	W\DPW\GIS\UROUND	ROUND	GOOD	NO	NO	NO	NO	NO	NO	NO	NO	NO	NO	NO	NO	ead00d4a-8dc1	-71.19108411	42.05406755	34	34	47	
18-06	2020-10-26	RN	12 IN	OUT	DRY	CONCRETE	NO	OUTFALL	MA62-27	W\DPW\GIS\UROUND	ROUND	GOOD	NO	NO	NO	NO	NO	NO	NO	NO	NO	NO	NO	NO	ef8d8be2-8516	-71.19328249	42.05366258	33	33	46	
18-05	2020-10-26	RN	12 IN	OUT	DRY	CONCRETE	NO	OUTFALL	MA62-27	W\DPW\GIS\UROUND	ROUND	GOOD	NO	NO	NO	NO	NO	NO	NO	NO	NO	NO	NO	NO	fe9056f2-5f3a	-71.19328945	42.05365244	32	32	45	
18-04	2020-10-26	RN	16 IN	OUT	DRY	CONCRETE	NO	OUTFALL	MA62-27	W\DPW\GIS\UROUND	ROUND	GOOD	NO	NO	NO	NO	NO	NO	NO	NO	NO	NO	NO	NO	a0a7479a-2c4a	-71.19338101	42.05334483	31	31	44	
17-07	2020-10-26	RN	30 IN	OUT	MODERATE	CORRUGATED METAL	NO	OUTFALL	MA62-39	W\DPW\GIS\UROUND	ROUND	GOOD	YES	NO	NO	NO	NO	NO	NO	NO	NO	NO	NO	NO	858126c0-856d	-71.21141271	42.05493664	38	38	52	
17-02	2020-10-26	RN	15 IN	OUT	DRY	CONCRETE	NO	OUTFALL	MA62-39	W\DPW\GIS\UROUND	ROUND	GOOD	NO	NO	NO	NO	NO	NO	NO	NO	NO	NO	NO	NO	4b3d2dac-cc39	-71.20845489	42.05227523	214	214	214	
14-14	2020-10-26	RN	12 IN	OUT	DRY	CONCRETE	NO	OUTFALL	MA62-39	W\DPW\GIS\UROUND	ROUND	GOOD	NO	NO	NO	NO	NO	NO	NO	NO	NO	NO	NO	NO	e511fb51-394b	-71.19645666	42.05650844	253	253	253	
14-13	2020-10-26	RN	18 IN	OUT	DRY	CONCRETE	NO	OUTFALL	MA62-39	W\DPW\GIS\UROUND	ROUND	GOOD	NO	NO	NO	NO	NO	NO	NO	NO	NO	NO	NO	NO	a39965d4-de21	-71.19648718	42.05654329	252	252	252	
14-12	2020-10-26	RN	15 IN	OUT	DRY	CONCRETE	NO	OUTFALL	MA62-39	W\DPW\GIS\UROUND	ROUND	GOOD	NO	NO	NO	NO	NO	NO	NO	NO	NO	NO	NO	NO	55161844-7546	-71.19642459	42.05497679	236	236	236	
14-05	2020-10-26	RN	15 IN	OUT	DRY	CONCRETE	NO	OUTFALL	MA62-27	W\DPW\GIS\UROUND	ROUND	GOOD	NO	NO	NO	NO	NO	NO	NO	NO	NO	NO	NO	NO	78e888e0-aa05	-71.20090435	42.05996344	27	27	27	
14-02	2020-10-26	RN	12 IN	OUT	DRY	OTHER	NO	OUTFALL	MA62-27	W\DPW\GIS\UROUND	ROUND	GOOD	NO	NO	NO	NO	NO	NO	NO	NO	NO	NO	NO	NO	c21931e1-6d5e	-71.20683537	42.06129291	21	21	21	
14-01	2020-10-26	RN	18 IN	OUT	TRICKLING	CONCRETE	NO	OUTFALL	MA62-27	W\DPW\GIS\UROUND	ROUND	GOOD	YES	NO	NO	NO	NO	NO	NO	NO	NO	NO	NO	NO	d82a64b6-c221	-71.19838905	42.05534631	20	20	20	
13-04	2020-10-26	RN	24 IN	OUT	TRICKLING	CORRUGATED METAL	YES	OUTFALL	MA62-39	W\DPW\GIS\UROUND	ROUND	GOOD	YES	NO	NO	NO	NO	NO	NO	NO	NO	NO	NO	NO	f78d748f-4994	-71.21182263	42.06098982	40	40	40	
13-03	2020-10-26	RN	12 IN	OUT	DRY	CONCRETE	NO	OUTFALL	MA62-39	W\DPW\GIS\UROUND	ROUND	GOOD	NO	NO	NO	NO	NO	NO	NO	NO	NO	NO	NO	NO	fa36c311-af60	-71.21303546	42.05764822	37	37	37	
13-02	2020-10-26	LD	27 IN	OUT	DRY	CONCRETE	NO	OUTFALL	MA62-39	W\DPW\GIS\UROUND	ROUND	GOOD	NO	NO	NO	NO	NO	NO	NO	NO	NO	NO	NO	NO	5714e943-cc37	-71.22985919	42.06057381	16	16	23	
13-01	2020-10-26	RN	18 IN	OUT	DRY	CONCRETE	NO	OUTFALL	MA62-39	W\DPW\GIS\UROUND	ROUND	GOOD	NO	NO	NO	NO	NO	NO	NO	NO	NO	NO	NO	NO	67909f46-5084	-71.23038677	42.06044118	15	15	22	
13-20	2020-10-25	RN	24 IN	OUT	DRY	CONCRETE	NO	OUTFALL	MA62-39	W\DPW\GIS\UROUND	ROUND	GOOD	NO	NO	NO	NO	NO	NO	NO	NO	NO	NO	NO	NO	70688729-8d2f	-71.21232762	42.06238433	255	255	255	
13-19	2020-10-25	RN	12 IN	OUT	DRY	CONCRETE	NO	OUTFALL	MA62-39	W\DPW\GIS\UROUND	ROUND	GOOD	NO	NO	NO	NO	NO	NO	NO	NO	NO	NO	NO	NO	644ad679-adff	-71.20725676	42.05957958	251	251	251	
14-11	2020-10-19	LD	24 IN	OUT	DRY	CONCRETE	NO	OUTFALL	MA62-27	W\DPW\GIS\UROUND	ROUND	GOOD	NO	NO	NO	NO	NO	NO	NO	NO	NO	NO	NO	NO	11c1bc522-39d7	-71.19944253	42.06356574	99	99	148	
14-09	2020-10-19	LD	8 IN	OUT	DRY	OTHER	NO	OUTFALL	MA62-27	W\DPW\GIS\UROUND	ROUND	GOOD	NO	NO	NO	NO	NO	NO	NO	NO	NO	NO	NO	NO	e196c2f1-efbc	-71.19671081	42.06604131	96	96	96	
14-08	2020-10-19	LD	12 IN	OUT	DRY	CONCRETE	NO	OUTFALL	MA62-27	W\DPW\GIS\UROUND	ROUND	FAIR	NO	NO	NO	NO	NO	NO	NO	NO	NO	NO	NO	NO	234286ff-cb20	-71.19631007	42.06762985	95	95	144	
14-07	2020-10-19	LD	12 IN	OUT	DRY	CONCRETE	NO	OUTFALL	MA62-27	W\DPW\GIS\UROUND	ROUND	FAIR	YES	NO	NO	NO	NO	NO	NO	NO	NO	NO	NO	NO	e7c37ddc-a082	-71.20419027	42.06235576	36	36	50	
14-06	2020-10-19	LD	12 IN	OUT	DRY	CONCRETE	NO	OUTFALL	MA62-27	W\DPW\GIS\UROUND	ROUND	GOOD	NO	NO	NO	NO	NO	NO	NO	NO	NO	NO	NO	NO	2abcb2fd-07ba	-71.20616976	42.06291527	30	30	41	
14-04	2020-10-19	LD	12 IN	OUT	DRY	CONCRETE	NO	OUTFALL	MA62-27	W\DPW\GIS\UROUND	ROUND	GOOD	NO	NO	NO	NO	NO	NO	NO	NO	NO	NO	NO	NO	99dafd8e-5fbc	-71.20422547	42.06256363	23	23	31	
14-03	2020-10-19	LD	12 IN	OUT	DRY	CONCRETE	NO	OUTFALL	MA62-27	W\DPW\GIS\UROUND	ROUND	FAIR	YES	NO	NO	NO	NO	NO	NO	NO	NO	NO	NO	NO	be8f0754-70b2	-71.20419371	42.06235313	22	22	30	
10-02	2020-10-19	LD	10 IN	OUT	DRY	CONCRETE	NO	OUTFALL	MA62-27	W\DPW\GIS\UROUND	ROUND	GOOD	YES	NO	NO	NO	NO	NO	NO	NO	NO	NO	NO	NO	6b7029a9-d942	-71.19669547	42.07237427	94	94	143	
10-01	2020-10-19	LD	12 IN	OUT	DRY	CONCRETE	NO	OUTFALL	MA62-27	W\DPW\GIS\UROUND	ROUND	GOOD	NO	NO	NO	NO	NO	NO	NO	NO	NO	NO	NO	NO	363fa6fa-812a	-71.19658672	42.07315155	93	93	142	
13-21	2020-10-07	LD	12 IN	OUT	DRY	CONCRETE	NO	OUTFALL	MA62-39	W\DPW\GIS\UROUND	ROUND	FAIR	NO	NO	NO	NO	NO	NO	NO	NO	NO	NO	NO	NO	2792a639-230c	-71.21866714	42.06606271	262	262	364	
13-07	2020-10-07	LD	15 IN	OUT	DRY	CONCRETE	NO	OUTFALL	MA62-39	W\DPW\GIS\UROUND	ROUND	GOOD	NO	NO	NO	NO	NO	NO	NO	NO	NO	NO	NO	NO	7ee3c953-6169	-71.21956568	42.06640583	45	45	65	
09-22	2020-10-07	LD	18 IN	OUT	DRY	CONCRETE	NO	OUTFALL	MA62-39	W\DPW\GIS\UROUND	ROUND	GOOD	NO	NO	NO	NO	NO	NO	NO	NO	NO	NO	NO	NO	959dadf1-efc2	-71.21455187	42.07575028	229	229	330	
09-21	2020-10-07	LD	18 IN	OUT	DRY	CONCRETE	NO	OUTFALL	MA62-39	W\DPW\GIS\UROUND	ROUND	GOOD	NO	NO	NO	NO	NO	NO	NO	NO	NO	NO	NO	NO	64012dc9-d886	-71.21580113	42.07897597	228	228	329	
09-11	2020-10-07	LD	15 IN	OUT	DRY	CORRUGATED METAL	NO	OUTFALL	MA62-39	W\DPW\GIS\UROUND	ROUND	POOR	NO	NO	NO	NO	NO	NO	NO	NO	NO	NO	NO	NO	d79fa2dd-5fad	-71.2223822	42.07692834	156	156	244	
09-10	2020-10-07	LD	18 IN	OUT	DRY	CONCRETE	NO	OUTFALL	MA62-39	W\DPW\GIS\UROUND	ROUND	GOOD	NO	NO	NO	NO	NO	NO	NO	NO	NO	NO	NO	NO	2a1e3662-922f	-71.21644469	42.06948349	115	115	168	
09-08	2020-10-07	LD	18 IN	OUT	DRY	CONCRETE	NO	OUTFALL	MA62-39	W\DPW\GIS\UROUND	ROUND	GOOD	NO	NO	NO	NO	NO	NO	NO	NO	NO	NO	NO	NO	4f49d9b9-2df7	-71.21020481	42.07317315	53	53	76	
09-04	2020-10-07	LD	12 IN	OUT	DRY	CONCRETE	NO	OUTFALL	MA62-39	W\DPW\GIS\UROUND	ROUND	GOOD	NO	NO	NO	NO	NO	NO	NO	NO	NO	NO	NO	NO	31845b6b-993e	-71.21107632	42.07381549	49	49	72	
09-03	2020-10-07	LD	15 IN	OUT	DRY	CONCRETE	NO	OUTFALL	MA62-39	W\DPW\GIS\UROUND	ROUND	FAIR	NO	NO	NO	NO	NO	NO	NO	NO	NO	NO	NO	NO	d7eb6bac-c895	-71.21767838	42.07434001	47	47	69	
09-02	2020-10-07	LD	36 IN	OUT	DRY	CORRUGATED METAL	NO	OUTFALL	Taunton Riv	W\DPW\GIS\UROUND	ROUND	FAIR	YES	NO	NO	NO	NO	NO	NO	NO	NO	NO	NO	NO	NO	1bf5675b-ec22	-71.21891938	42.07050497	44	44	63
09-01	2020-10-07	LD	12 IN	OUT	DRY	CONCRETE	NO	OUTFALL	Taunton Riv	W\DPW\GIS\UROUND	ROUND	FAIR	NO	NO	NO	NO	NO	NO	NO	NO	NO	NO	NO	NO	266ba790-811c	-71.21932995	42.07430149	41	41	60	
06-08	2020-10-07	LD	15 IN	OUT	DRY	CORRUGATED METAL	NO	OUTFALL	Taunton Riv	W\DPW\GIS\UROUND	ROUND	POOR	NO	NO	NO	NO	NO	NO	NO	NO	NO	NO	NO	NO	43cd16b2-f7d3	-71.21874482	42.08394866	155	155	243	
06-07	2020-10-07	LD	24 IN	OUT	DRY	CONCRETE	NO	OUTFALL	Taunton Riv	W\DPW\GIS\UROUND	ROUND	FAIR	YES	NO	NO	NO	NO	NO	NO	NO	NO	NO	NO	NO	NO	469c03e4-7a62	-71.21770757	42.08354339	154	154	242

Town of Foxborough, MA  
FY21 Outfall Inspections

Point_ID	DOI	INSPECTOR	DIAMETER	DIRECTION	FLOW	MATERIAL	ODOR	Point_Code	AU_ID	IMAGE_	END_SHAPE	CONDITION	SUBMERGED	ODOR_COMM	COLOR	COLOR_COMM	OTHER_MATE	SHEEN	SHEEN_COMM	TURBIDITY	TURBIDITY_	FLOATABLES	FLOATABLE_1	OTHER_SHAP	NOTES	GlobalID	x	y	FID	OBJECTID_1	OBJECTID_2	OBJECTID
05-09	2020-08-21	LD	12 IN	OUT	DRY	CONCRETE	NO	OUTFALL	MA73-01	MC2	ROUND	GOOD	NO	NO	NO	NO		NO	NO	NO	NO	NO	NO	NO		10f66972-a9d5	-71.25484043	42.09056794	180	180	180	274
05-08	2020-08-21	LD	18 IN	OUT	DRY	CONCRETE	NO	OUTFALL	MA73034	MC1	ROUND	GOOD	NO	NO	NO	NO		NO	NO	NO	NO	NO	NO	NO		311a5906-de2a	-71.25092635	42.08797942	179	179	179	273
06-12	2020-08-11	LD	12 IN	OUT	DRY	CONCRETE	NO	OUTFALL	Taunton Riv	IV1	ROUND	FAIR	NO	NO	NO	NO		NO	NO	NO	NO	NO	NO	NO		fe5d1066-8416	-71.23320149	42.0891237	178	178	178	272
06-11	2020-08-11	LD	12 IN	OUT	DRY	CONCRETE	NO	OUTFALL	Taunton Riv	HO 1	ROUND	GOOD	NO	NO	NO	NO		NO	NO	NO	NO	NO	NO	NO		b2bcb444-dfco	-71.2302437	42.09155336	177	177	177	270
06-10	2020-08-11	LD	18 IN	OUT	DRY	CONCRETE	NO	OUTFALL	Taunton Riv	HILL 2	ROUND	GOOD	NO	NO	NO	NO		NO	NO	NO	NO	NO	NO	NO		8f50f4e5-6b15	-71.23066516	42.09279716	176	176	176	269
06-09	2020-08-11	LD	12 IN	OUT	DRY	CONCRETE	NO	OUTFALL	Taunton Riv	HILL 1	ROUND	FAIR	NO	NO	NO	NO		NO	NO	NO	NO	NO	NO	NO		4e8c92c8-3e3c	-71.2304127	42.09264888	175	175	175	268
06-06	2020-08-11	LD	12 IN	OUT	DRY	CONCRETE	NO	OUTFALL	Taunton Riv	W:\DPW\GIS\U\ROUND	ROUND	GOOD	NO	NO	NO	NO		NO	NO	NO	NO	NO	NO	partly buried	ae93dcd0-d093	-71.23014434	42.09131447	144	144	144	221	
06-05	2020-08-11	LD	12 IN	OUT	DRY	CONCRETE	NO	OUTFALL	Taunton Riv	W:\DPW\GIS\U\ROUND	ROUND	GOOD	NO	NO	NO	NO		NO	NO	NO	NO	NO	NO	partly buried	b53b2ede-b6a5	-71.22831083	42.09175576	143	143	143	220	
06-04	2020-08-11	LD	18 IN	OUT	DRY	CONCRETE	NO	OUTFALL	Taunton Riv	W:\DPW\GIS\U\ROUND	ROUND	GOOD	NO	NO	NO	NO		NO	NO	NO	NO	NO	NO	right of culvert	7620290b-c039	-71.23253458	42.09181862	142	142	142	219	
05-16	2020-08-11	LD	24 IN		DRY	CONCRETE	NO	OUTFALL			ROUND	GOOD	NO	NO	NO	NO		NO	NO	NO	NO	NO	NO	TO BASIN	00617827-1304	-71.23524364	42.08594872	217	217	217	316	
05-06	2020-08-11	LD	12 IN	OUT	DRY	PVC	NO	OUTFALL	MA73034	W:\DPW\GIS\U\ROUND	ROUND	GOOD	NO	NO	NO	NO		NO	NO	NO	NO	NO	NO		d14433b0-7665	-71.23765803	42.0918327	149	149	149	228	
05-05	2020-08-11	LD	18 IN	OUT	DRY	CONCRETE	NO	OUTFALL	MA73034	W:\DPW\GIS\U\ROUND	ROUND	GOOD	NO	NO	NO	NO		NO	NO	NO	NO	NO	NO	standing water	ea46c953-ab60	-71.23765997	42.0918508	148	148	148	227	
05-01	2020-08-11	LD	24 IN	OUT	DRY	CONCRETE	NO	OUTFALL	MA73034	W:\DPW\GIS\U\ROUND	ROUND	GOOD	YES	NO	NO	NO		NO	NO	NO	NO	NO	NO	dry at open joint	db155315-6ecc	-71.23720533	42.08820596	135	135	135	212	
02-10	2020-08-11	LD	18 IN	OUT	DRY	CONCRETE	NO	OUTFALL	MA73-01	106_2	ROUND	GOOD	NO	NO	NO	NO		NO	NO	NO	NO	NO	NO	beside culvert	d50d27d2-ca03	-71.24950532	42.0977295	173	173	173	266	
02-09	2020-08-11	LD	30 IN	OUT	DRY	CONCRETE	NO	OUTFALL	MA73034	107_1	ROUND	GOOD	NO	NO	NO	NO		NO	NO	NO	NO	NO	NO	standing water in pipe	72c73851-4d1a	-71.23725312	42.0961878	172	172	172	265	
02-05	2020-08-11	LD	12 IN	OUT	DRY	CONCRETE	NO	OUTFALL	MA73-01	W:\DPW\GIS\U\ROUND	ROUND	GOOD	NO	NO	NO	NO		NO	NO	NO	NO	NO	NO		8d977e2a-a49a	-71.23587545	42.09733528	141	141	141	218	
02-04	2020-08-11	LD	21 IN	OUT	DRY	CONCRETE	NO	OUTFALL	MA73-01	W:\DPW\GIS\U\ROUND	ROUND	GOOD	NO	NO	NO	NO		NO	NO	NO	NO	NO	NO		0df7ccc3-f352	-71.23589109	42.09734502	140	140	140	217	
02-01	2020-08-11	LD	24 IN	OUT	DRY	CONCRETE	NO	OUTFALL	MA73034	W:\DPW\GIS\U\ROUND	ROUND	GOOD	NO	NO	NO	NO		NO	NO	NO	NO	NO	NO		c778be5a-c0f9	-71.24379746	42.09693415	136	136	136	213	
NEWS	2020-08-10	LD	24 IN		DRY	CONCRETE	NO	OUTFALL			ROUND	GOOD	YES	NO	NO	NO		NO	NO	NO	NO	NO	NO	Submerged	d3450907-315f	-71.238498	42.09276779	273	273	273	0	
NEW4	2020-08-10	LD	36 IN		TRICKLING	CONCRETE	NO	OUTFALL			ROUND	GOOD	NO	YES	NO	NO		NO	NO	NO	NO	NO	NO	Near 05-07, culvert disregard	7f31d056-1562	-71.24135505	42.09355005	272	272	272	0	
05-18	2020-08-10	LD	24 IN		DRY	CONCRETE	NO	OUTFALL			ROUND	GOOD	NO	NO	NO	NO		NO	NO	NO	NO	NO	NO	standing water	b9209cc4-1214	-71.23955099	42.09307638	219	219	219	318	
05-17	2020-08-10	LD	36 IN		TRICKLING	CONCRETE	NO	OUTFALL			ROUND	GOOD	YES	NO	NO	NO		NO	NO	NO	NO	NO	NO	SUBMERGED	5574f076-fc97	-71.24104148	42.09326666	218	218	218	317	
05-13	2020-08-10	LD	12 IN	OUT	DRY	PVC	NO	OUTFALL	MA73034	TH2	ROUND	GOOD	NO	NO	NO	NO		NO	NO	NO	NO	NO	NO		52f9a51c-e4e2	-71.2441025	42.09444068	185	185	185	279	
05-12	2020-08-10	LD	7 IN	OUT	DRY	CONCRETE	NO	OUTFALL	MA73034	SH3	ROUND	GOOD	NO	NO	NO	NO		NO	NO	NO	NO	NO	NO		6f950ecd-4471	-71.24105709	42.08792984	183	183	183	277	
05-11	2020-08-10	LD	30 IN	OUT	DRY	OTHER	NO	OUTFALL	MA73034	SH2	OTHER	NO	NO	NO	NO	NO	Unknown	NO	NO	NO	NO	NO	NO	grate clogging with leaves/needles	6785ed5d-2b5f	-71.24710926	42.08829288	182	182	182	276	
05-10	2020-08-10	LD	24 IN	OUT	DRY	CONCRETE	NO	OUTFALL	MA73034	SH1	ROUND	GOOD	NO	NO	NO	NO		NO	NO	NO	NO	NO	NO	buried under yardwaste	1ea91f94-15b7	-71.24615106	42.09198301	181	181	181	275	
05-07	2020-08-10	LD	36 IN	OUT	TRICKLING	CONCRETE	NO	OUTFALL	MA73034	ED1	ROUND	GOOD	NO	YES	NO	NO	Brown	NO	NO	YES	NO	NO	NO	standing water	d7855225-05b4	-71.24143865	42.09356025	174	174	174	267	
05-02	2020-08-10	LD	36 IN	OUT	DRY	CONCRETE	NO	OUTFALL	MA73034	W:\DPW\GIS\U\ROUND	ROUND	FAIR	NO	NO	NO	NO		NO	NO	NO	NO	NO	NO	standing water	045211a9-a635	-71.24971406	42.09293508	139	139	139	216	
02-11	2020-08-10	LD	12 IN	OUT	DRY	PVC	NO	OUTFALL	MA73034	TH1	ROUND	GOOD	NO	NO	NO	NO		NO	NO	NO	NO	NO	NO		3ad4ee4d-2ff7	-71.24480863	42.09502735	184	184	184	278	
02-06	2020-08-10	LD	15 IN	OUT	DRY	CONCRETE	NO	OUTFALL	MA73-01	W:\DPW\GIS\U\ROUND	ROUND	GOOD	NO	NO	NO	NO		NO	NO	NO	NO	NO	NO		219e77c0-7bfb	-71.25425101	42.10153616	147	147	147	225	
02-03	2020-08-10	LD	12 IN	OUT	DRY	PVC	NO	OUTFALL	MA73-01	W:\DPW\GIS\U\RECTANGULAR	RECTANGULAR	GOOD	NO	NO	NO	NO		NO	NO	NO	NO	NO	NO	pic1	8885849e-8743	-71.25575724	42.09729336	138	138	138	215	
08-05	5/15/15	RN	7 IN	OUT		NONE	NONE	OUTFALL	MA73034	W:\DPW\GIS\Utilities\Drain\Images\															Saa44e9b-c3ad	-71.25853544	42.07498059	120	120	120	185	
08-03	5/15/15	RN	7 IN	OUT		NONE	NONE	OUTFALL	MA73034	W:\DPW\GIS\Utilities\Drain\Images\img_CHESTNUT ST A_150515_132301.jpg															e99262cb-7f51	-71.2513884	42.07538997	118	118	118	183	
14-10	4/28/15	RN	4 IN	OUT	NONE	CORRUGATED METAL	NONE	OUTFALL	MA62-27	W:\DPW\GIS\Utilities\Drain\Images\															be1fd95b-50b9	-71.19886497	42.06423096	97	97	97	146	
22-14	11/10/14	RN	7 IN	OUT		NONE	NONE	OUTFALL	MA62-47	W:\DPW\GIS\Utilities\Drain\Images\img_KING PHILIP 4_101114_164102.jpg															f287a2bf-7433	-71.26967637	42.02865997	80	80	80	118	
09-07	1969-12-31	RN	7 IN	OUT		NONE	NONE	OUTFALL	MA62-39	W:\DPW\GIS\Utilities\Drain\Images\img_LAMSON RD 10_271014_171648.jpg															abb3dba2-9a22	-71.20960585	42.07285588	52	52	52	75	
09-06	1969-12-31	RN	7 IN	OUT	NONE	CORRUGATED METAL	NONE	OUTFALL	MA62-39	W:\DPW\GIS\Utilities\Drain\Images\img_LAMSON RD 9_271014_171523.jpg																67e2886f-c86d	-71.2095521	42.07283696	51	51	51	74
06-13								OUTFALL																		15c36af1-e61c	-71.21946418	42.08212581	254	254	254	356

**Outfall ID:** Keryns1 (MA62009)

**Location Description:** Off of Keryns Way, behind 171 East Street

**Parameters:** Temperature, Conductivity, Salinity, Surfactants, Ammonia, Chlorine, E. coli or Enterococcus

Map

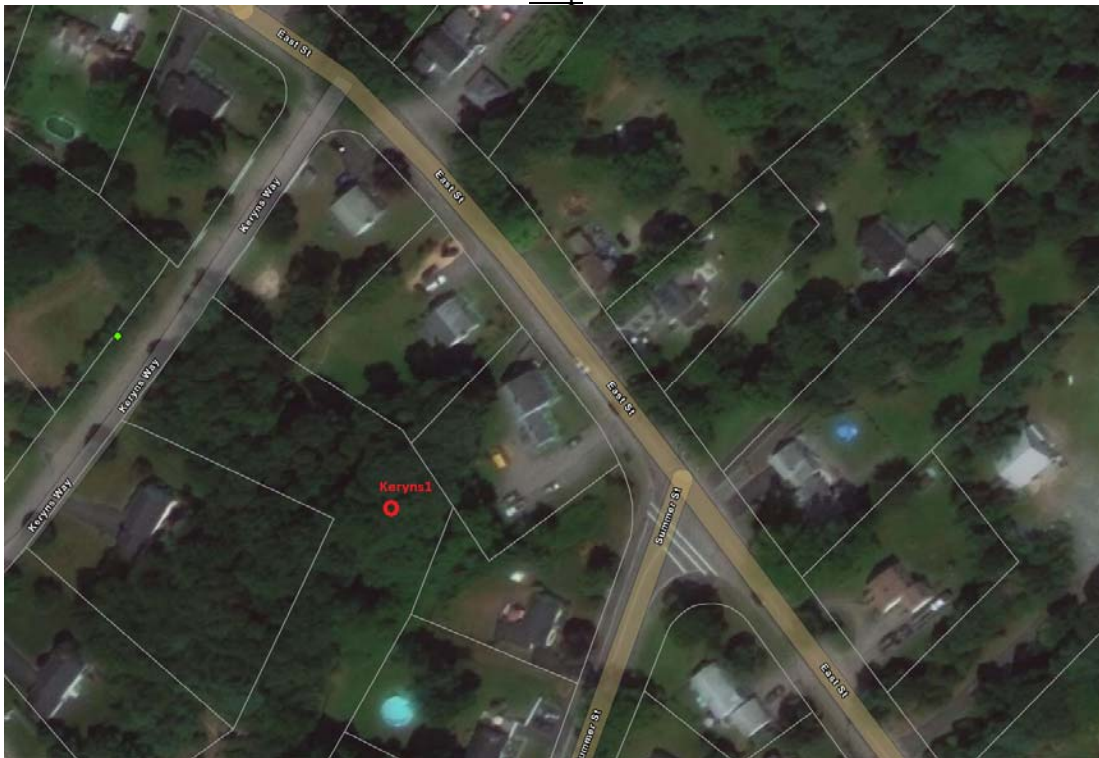

Picture





**Outfall ID:** 16-02

**Location Description:** 225 Foxborough Blvd

**Parameters:** Temperature, Conductivity, Salinity, Surfactants, Ammonia, Chlorine, E. coli or Enterococcus

Map



Picture





**Outfall ID:** 20-04

**Location Description:** Across the street from 25 Foxborough Blvd

**Parameters:** Temperature, Conductivity, Salinity, Surfactants, Ammonia, Chlorine, E. coli or Enterococcus

Map

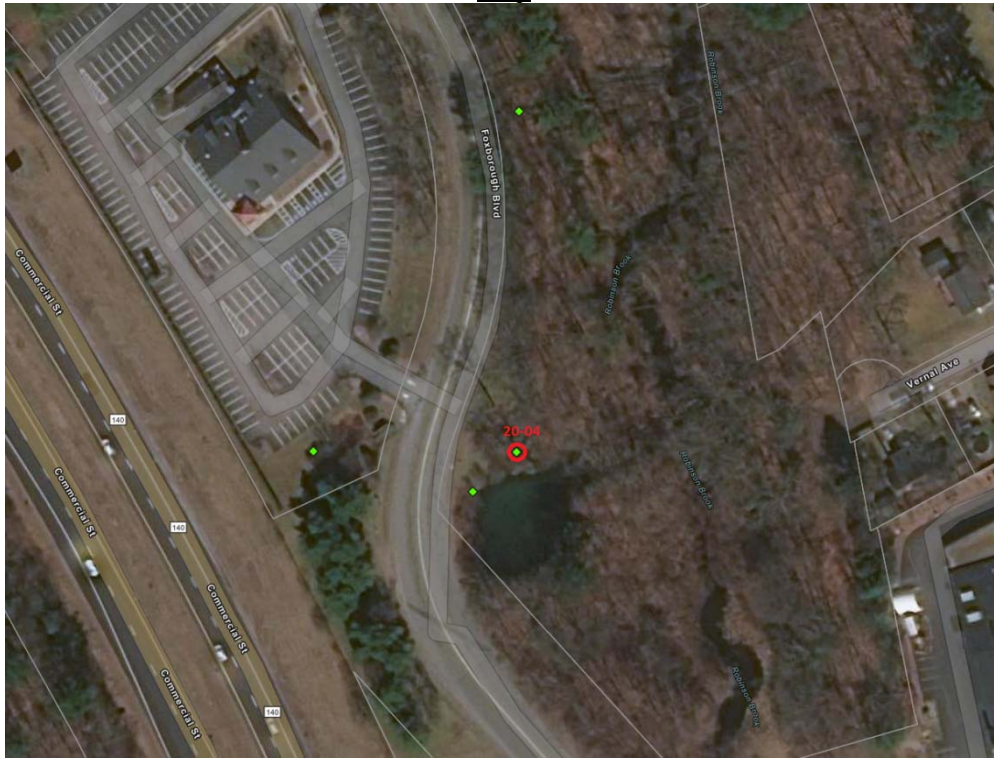

Picture





**Outfall ID:** 17-07

**Location Description:** Behind 24 & 20 Alden Street

**Parameters:** Temperature, Conductivity, Salinity, Surfactants, Ammonia, Chlorine, E. coli or Enterococcus, Total Suspended Solids

Map

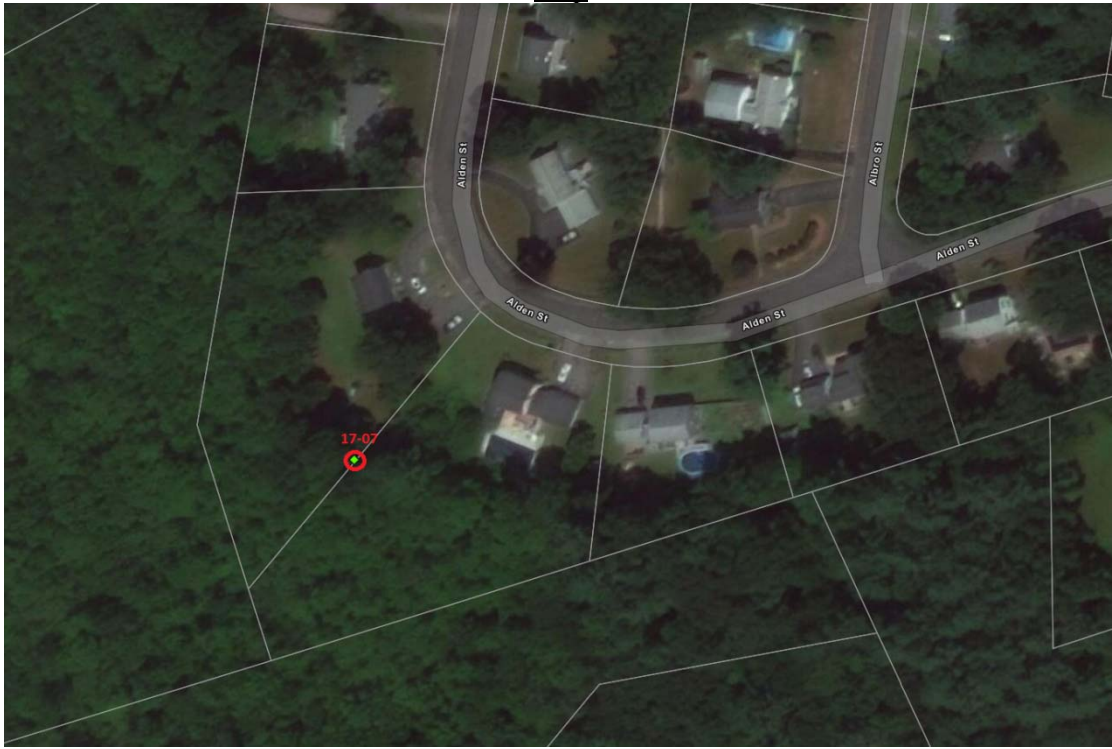

Picture





**Outfall ID:** 20-18

**Location Description:** Off Hutchins Drive near Kendall Drive

**Parameters:** Temperature, Conductivity, Salinity, Surfactants, Ammonia, Chlorine, E. coli or Enterococcus, Total Phosphorus (freshwater), Total Nitrogen (marine waters), Dissolved Oxygen, BOD5

Map

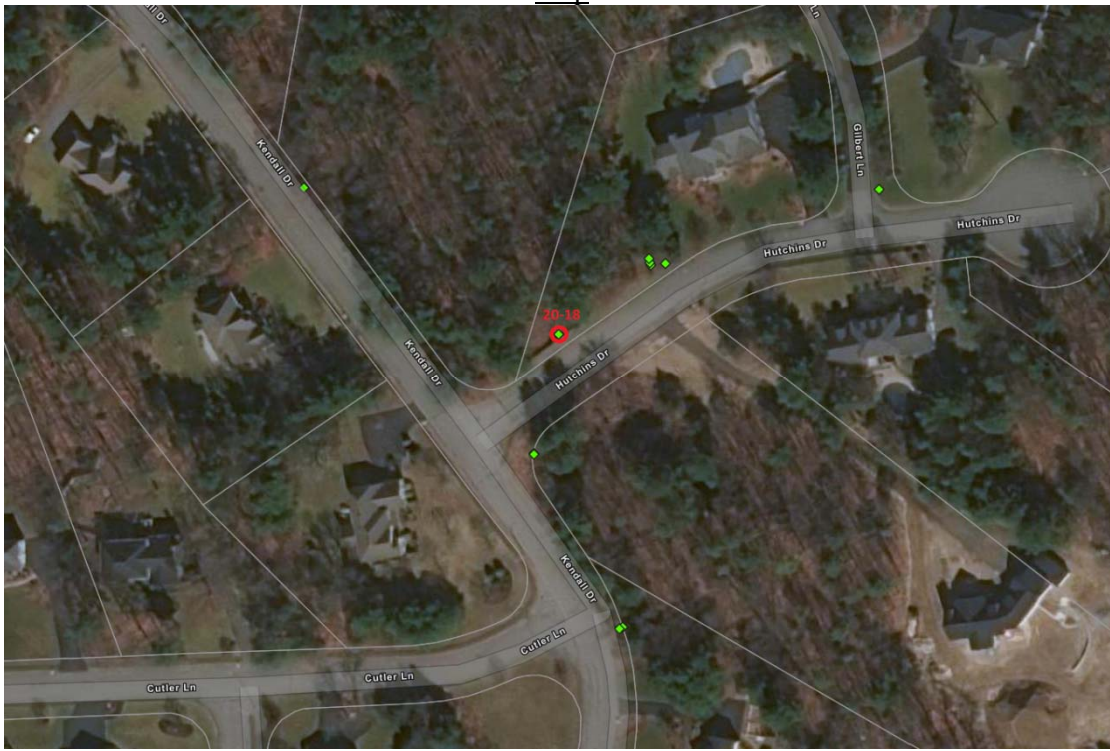

Picture





**Outfall ID:** 15-03

**Location Description:** Behind 10 Sheehan Way

**Parameters:** Temperature, Conductivity, Salinity, Surfactants, Ammonia, Chlorine, E. coli or Enterococcus, Total Phosphorus (freshwater), Total Nitrogen (marine waters), Dissolved Oxygen, BOD5

Map

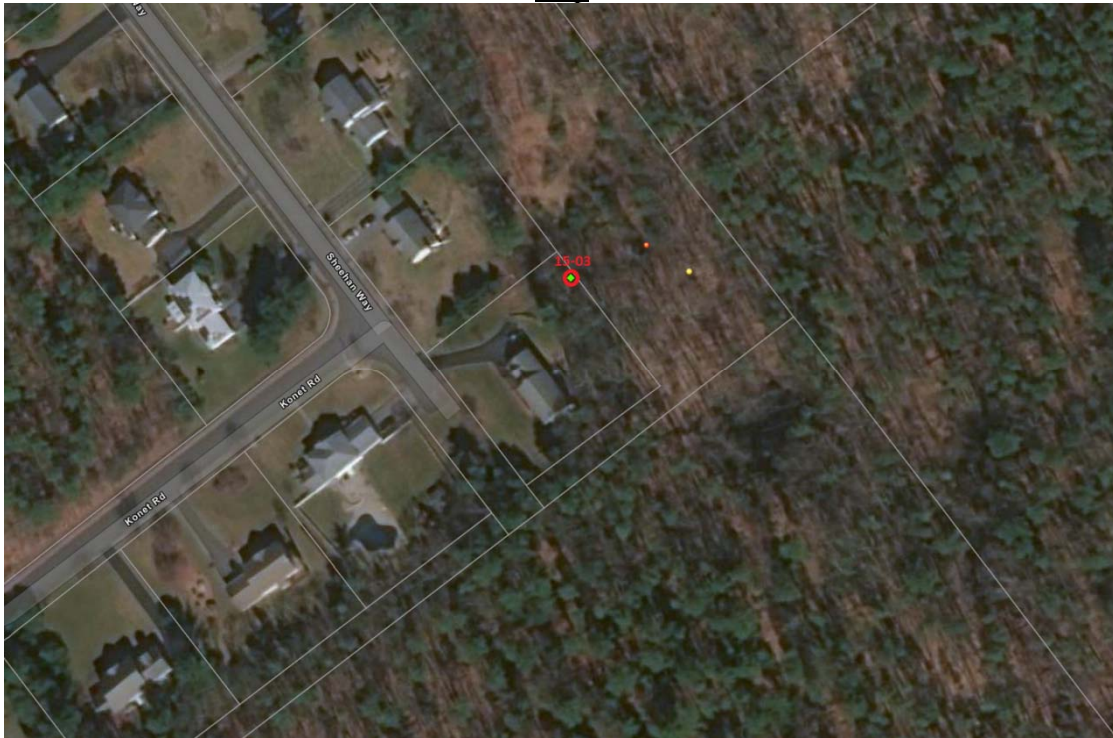

Picture





**Outfall ID:** 19-11

**Location Description:** 85 Fairway Lane

**Parameters:** Temperature, Conductivity, Salinity, Surfactants, Ammonia, Chlorine, E. coli or Enterococcus, Total Phosphorus (freshwater), Total Nitrogen (marine waters), Dissolved Oxygen, BOD5

Map

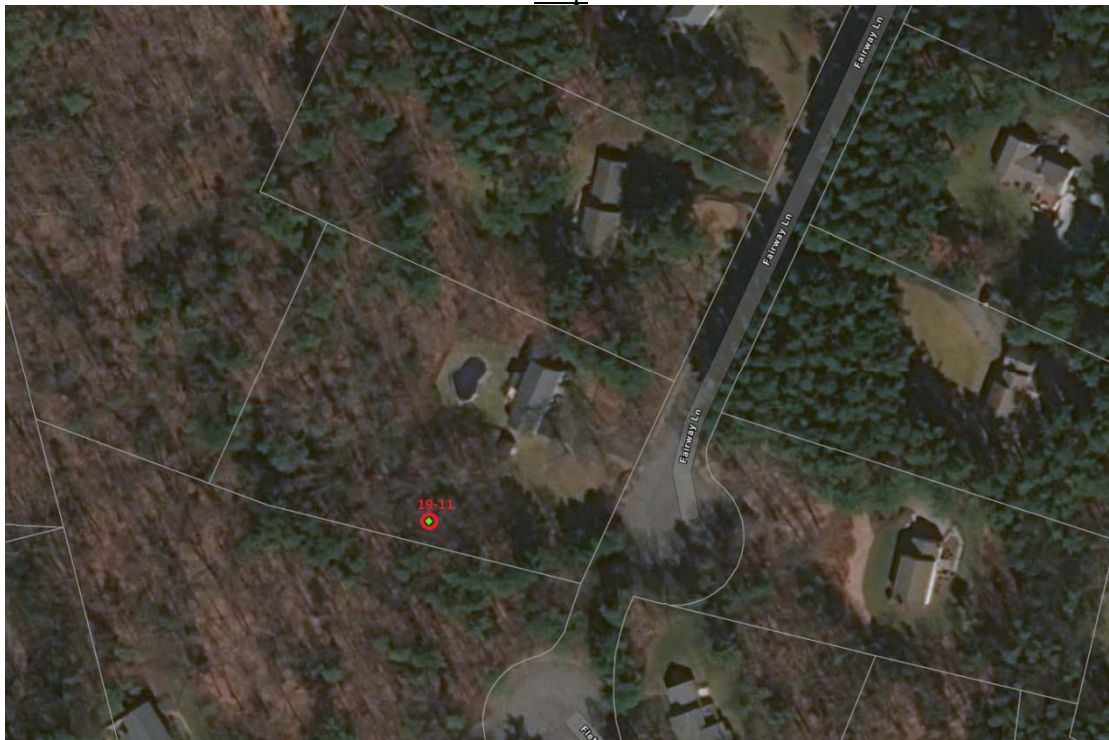

Picture





**Outfall ID:** 02-08

**Location Description:** Behind 17 Hartwell Drive

**Parameters:** Temperature, Conductivity, Salinity, Surfactants, Ammonia, Chlorine, E. coli or Enterococcus, Total Phosphorus (freshwater), Total Nitrogen (marine waters), Dissolved Oxygen, BOD5

Map

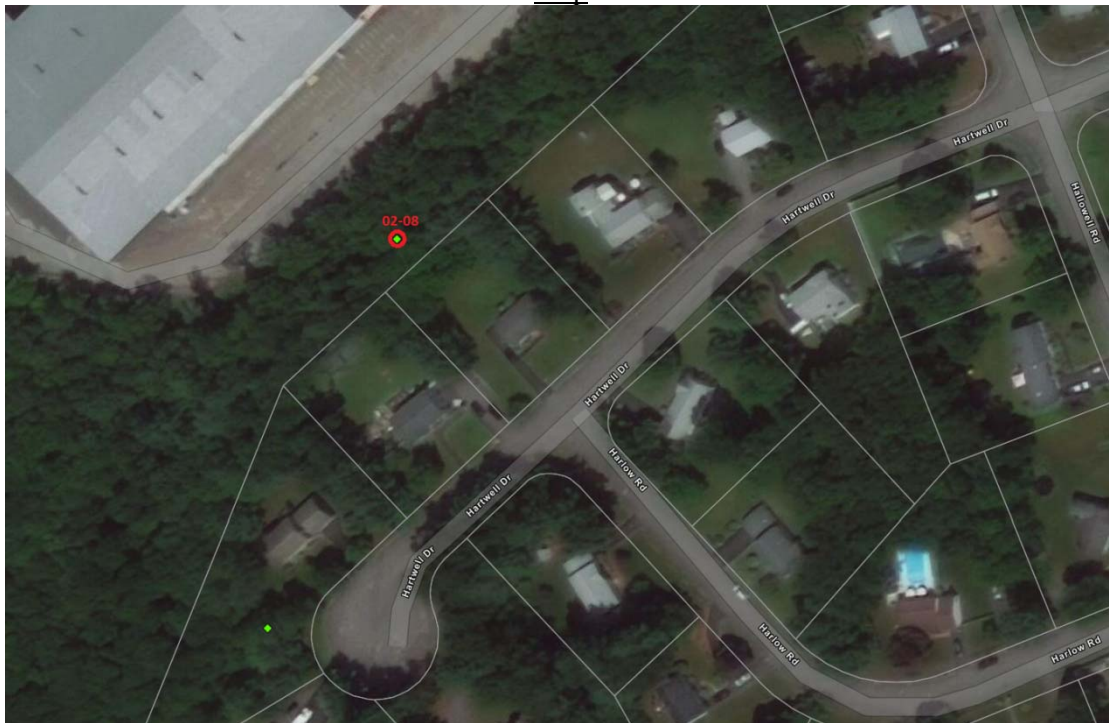

Picture





**Outfall ID:** Perry1 (MA73037)

**Location Description:** End of Perry Drive

**Parameters:** Temperature, Conductivity, Salinity, Surfactants, Ammonia, Chlorine, E. coli or Enterococcus, Total Phosphorus (freshwater), Total Nitrogen (marine waters), Dissolved Oxygen, BOD5

Map



Picture



**Stormwater Outfall Visual Inspection Form**Location I.D.: 02-08**General Information**

Inspector: Jake LeFeuvre Date & Time: 4/23/2021 11:05:00 AM  
Weather: 40s Sunny Precipitation: <0.1  
Sample Location: Jake LeFeuvre Dry / Wet: Dry  
Last Rain Event: 04/21/21 Land Use: Residential

**Pipe Information**

Receiving Water: Stormwater Pipe Size (in.): 24  
Pipe Shape: Circle Pipe Material: Corrugated metal  
Pipe Submerged: No If Yes - Percent Submerged: \_\_\_\_\_  
Pipe Notes: Rusted and at risk of failure

**Observations**

Flow: Yes If Flow - Velocity: Fast  
Deposits or Stains: None Sediment Depth (% of pipe): \_\_\_\_\_  
Other Deposits: \_\_\_\_\_ Sedimentation: No  
Vegetation: No Scouring: Yes  
Flow Source: City Visual Evidence of Illicit Discharge: Yes  
Comments: \_\_\_\_\_

**Sample Information - Field Parameters**

Sample Taken: Yes If No - Reason: \_\_\_\_\_  
Odor: None Clarity: Clear Turbidity (visual): Clear (0.73)  
Temperature (°C): 10.9 Color: None  
Conductivity (mS/cm): 0.428  
pH: 6.85  
Salinity (ppt): 0.21  
Ammonia (ppm): 0  
Chlorine (ppm): 0  
Surfactants (mg/L): 0.25  
DO (mg/L): 9.64



Outfall



**Stormwater Outfall Visual Inspection Form**Location I.D.: 15-03**General Information**

Inspector: Jake LeFeuvre Date & Time: 4/23/2021 11:35:00 AM  
Weather: 50s sunny Precipitation: <0.1  
Sample Location: Outfall Dry / Wet: Dry  
Last Rain Event: 04/21/21 Land Use: Residential

**Pipe Information**

Receiving Water: Stormwater Pipe Size (in.): 24  
Pipe Shape: Circle Pipe Material: Concrete  
Pipe Submerged: No If Yes - Percent Submerged: \_\_\_\_\_  
Pipe Notes: \_\_\_\_\_

**Observations**

Flow: Yes If Flow - Velocity: Moderate  
Deposits or Stains: Stains Sediment Depth (% of pipe): \_\_\_\_\_  
Other Deposits: \_\_\_\_\_ Sedimentation: No  
Vegetation: No Scouring: No  
Flow Source: City Visual Evidence of Illicit Discharge: Yes  
Comments: \_\_\_\_\_

**Sample Information - Field Parameters**

Sample Taken: Yes If No - Reason: \_\_\_\_\_  
Odor: None Clarity: Clear Turbidity (visual): Clear  
Temperature (°C): 10.7 Color: None  
Conductivity (mS/cm): 0.251  
pH: 7.36  
Salinity (ppt): 0.12  
Ammonia (ppm): 0  
Chlorine (ppm): 0  
Surfactants (mg/L): 0.25  
DO (mg/L): 9.64



Outfall

**Stormwater Outfall Visual Inspection Form**Location I.D.: 16-02**General Information**

Inspector: Jake LeFeuvre Date & Time: 4/23/2021 8:15:20 AM  
Weather: 40s Sunny Precipitation: <0.1  
Sample Location: Outfall Dry / Wet: Dry  
Last Rain Event: 04/21/21 Land Use: Commercial

**Pipe Information**

Receiving Water: Stormwater Pipe Size (in.): 60  
Pipe Shape: Circle Pipe Material: Concrete  
Pipe Submerged: No If Yes - Percent Submerged: \_\_\_\_\_  
Pipe Notes: \_\_\_\_\_

**Observations**

Flow: Yes If Flow - Velocity: Trickle  
Deposits or Stains: Stains Sediment Depth (% of pipe): \_\_\_\_\_  
Other Deposits: \_\_\_\_\_ Sedimentation: No  
Vegetation: Yes Scouring: No  
Flow Source: City Visual Evidence of Illicit Discharge: Yes  
Comments: \_\_\_\_\_

**Sample Information - Field Parameters**

Sample Taken: Yes If No - Reason: \_\_\_\_\_  
Odor: None Clarity: Clear Turbidity (visual): Clear  
Temperature (°C): 11.6 Color: None  
Conductivity (mS/cm): 1.940  
pH: 6.69  
Salinity (ppt): 0.99  
Ammonia (ppm): 0  
Chlorine (ppm): 0  
Surfactants (mg/L): 0.5  
DO (mg/L): 9.08





16-02

**Stormwater Outfall Visual Inspection Form**Location I.D.: 17-07**General Information**

Inspector: Jake LeFeuvre Date & Time: 4/23/2021 9:15:00 AM  
Weather: 40s sunny Precipitation: <0.1  
Sample Location: Outfall Dry / Wet: Dry  
Last Rain Event: 04/21/21 Land Use: Residential

**Pipe Information**

Receiving Water: Stormwater Pipe Size (in.): 18  
Pipe Shape: Circle Pipe Material: Corrugated metal  
Pipe Submerged: Yes If Yes - Percent Submerged: 25  
Pipe Notes:

**Observations**

Flow: Yes If Flow - Velocity: Moderate  
Deposits or Stains: Sediment Sediment Depth (% of pipe): 5  
Other Deposits: \_\_\_\_\_ Sedimentation: Yes  
Vegetation: Yes Scouring: No  
Flow Source: City Visual Evidence of Illicit Discharge: Yes  
Comments:

**Sample Information - Field Parameters**

Sample Taken: Yes If No - Reason: \_\_\_\_\_  
Odor: None Clarity: Clear Turbidity (visual): Clear (0.61)  
Temperature (°C): 10.6 Color: Tan tint  
Conductivity (mS/cm): 0.481  
pH: 5.57  
Salinity (ppt): 0.23  
Ammonia (ppm): 0  
Chlorine (ppm): 0  
Surfactants (mg/L): 0  
DO (mg/L): 9.63



17-07

**Stormwater Outfall Visual Inspection Form**Location I.D.: 19-11**General Information**

Inspector: Jake LeFeuvre Date & Time: 4/23/2021 12:05:00 PM  
Weather: 50s sunny Precipitation: <0.1  
Sample Location: Outfall Dry / Wet: Dry  
Last Rain Event: 04/21/21 Land Use: Residential

**Pipe Information**

Receiving Water: Stormwater Pipe Size (in.): 24  
Pipe Shape: Circle Pipe Material: Concrete  
Pipe Submerged: No If Yes - Percent Submerged: \_\_\_\_\_  
Pipe Notes:

**Observations**

Flow: Yes If Flow - Velocity: Trickle  
Deposits or Stains: Stains Sediment Depth (% of pipe): \_\_\_\_\_  
Other Deposits: \_\_\_\_\_ Sedimentation: No  
Vegetation: Yes Scouring: No  
Flow Source: City Visual Evidence of Illicit Discharge: Yes  
Comments:

**Sample Information - Field Parameters**

Sample Taken: Yes If No - Reason: \_\_\_\_\_  
Odor: None Clarity: Clear Turbidity (visual): Clear  
Temperature (°C): 8.6 Color: None  
Conductivity (mS/cm): 1.143  
pH: 6.20  
Salinity (ppt): 0.57  
Ammonia (ppm): 0  
Chlorine (ppm): 0  
Surfactants (mg/L): 0.25  
DO (mg/L): 8.96



Outfall

**Stormwater Outfall Visual Inspection Form**Location I.D.: 20-04**General Information**

Inspector: Jake LeFeuvre Date & Time: 4/23/2021 8:45:00 AM  
Weather: 40s Sunny Precipitation: <0.1  
Sample Location: Outfall Dry / Wet: Dry  
Last Rain Event: 04/21/21 Land Use: Commercial

**Pipe Information**

Receiving Water: Stormwater Pipe Size (in.): 18  
Pipe Shape: Circle Pipe Material: Concrete  
Pipe Submerged: Yes If Yes - Percent Submerged: \_\_\_\_\_  
Pipe Notes: \_\_\_\_\_

**Observations**

Flow: No If Flow - Velocity: \_\_\_\_\_  
Deposits or Stains: Sediment Sediment Depth (% of pipe): 40  
Other Deposits: \_\_\_\_\_ Sedimentation: Yes  
Vegetation: Yes Scouring: No  
Flow Source: City Visual Evidence of Illicit Discharge: No  
Comments: \_\_\_\_\_

**Sample Information - Field Parameters**

Sample Taken: No If No - Reason: No flow  
Odor: \_\_\_\_\_ Clarity: \_\_\_\_\_ Turbidity (visual): \_\_\_\_\_  
Temperature (° C): \_\_\_\_\_ Color: \_\_\_\_\_  
Conductivity (mS/cm): \_\_\_\_\_  
pH: \_\_\_\_\_  
Salinity (ppt): \_\_\_\_\_  
Ammonia (ppm): \_\_\_\_\_  
Chlorine (ppm): \_\_\_\_\_  
Surfactants (mg/L): \_\_\_\_\_  
DO (mg/L): \_\_\_\_\_



20-04



MH Upstream from outfall

**Stormwater Outfall Visual Inspection Form**Location I.D.: 20-18**General Information**

Inspector: Jake LeFeuvre Date & Time: 4/23/2021 12:30:00 PM  
Weather: 50s Sunny Precipitation: <0.1  
Sample Location: Outfall Dry / Wet: Dry  
Last Rain Event: 04/21/21 Land Use: Residential

**Pipe Information**

Receiving Water: Stormwater Pipe Size (in.): 6  
Pipe Shape: Circle Pipe Material: PVC  
Pipe Submerged: No If Yes - Percent Submerged: \_\_\_\_\_  
Pipe Notes: \_\_\_\_\_

**Observations**

Flow: Yes If Flow - Velocity: Moderate  
Deposits or Stains: Stains Sediment Depth (% of pipe): \_\_\_\_\_  
Other Deposits: \_\_\_\_\_ Sedimentation: No  
Vegetation: No Scouring: No  
Flow Source: City Visual Evidence of Illicit Discharge: Yes  
Comments: \_\_\_\_\_

**Sample Information - Field Parameters**

Sample Taken: Yes If No - Reason: \_\_\_\_\_  
Odor: None Clarity: Clear Turbidity (visual): Clear  
Temperature (°C): 9.6 Color: None  
Conductivity (mS/cm): 0.424  
pH: 5.79  
Salinity (ppt): 0.21  
Ammonia (ppm): 0  
Chlorine (ppm): 0  
Surfactants (mg/L): 0.25  
DO (mg/L): 7.5





Outfall

## Stormwater Outfall Visual Inspection Form

Location I.D.: MA-62009

### General Information

Inspector: Jake LeFeuvre Date & Time: 4/23/2021 9:50:00 AM  
 Weather: 40s Sunny Precipitation: <0.1  
 Sample Location: Outfall Dry / Wet: Dry  
 Last Rain Event: 04/21/21 Land Use: Residential

### Pipe Information

Receiving Water: Stormwater Pipe Size (in.): 12  
 Pipe Shape: Circle Pipe Material: Concrete  
 Pipe Submerged: No If Yes - Percent Submerged: \_\_\_\_\_  
 Pipe Notes: \_\_\_\_\_

### Observations

Flow: Yes If Flow - Velocity: Moderate  
 Deposits or Stains: Stains Sediment Depth (% of pipe): \_\_\_\_\_  
 Other Deposits: \_\_\_\_\_ Sedimentation: No  
 Vegetation: No Scouring: No  
 Flow Source: City Visual Evidence of Illicit Discharge: Yes  
 Comments: \_\_\_\_\_

### Sample Information - Field Parameters

Sample Taken: Yes If No - Reason: \_\_\_\_\_  
 Odor: None Clarity: Clear Turbidity (visual): Clear (0.02)  
 Temperature (°C): 11.4 Color: None  
 Conductivity (mS/cm): 0.566  
 pH: 6.15  
 Salinity (ppt): 0.28  
 Ammonia (ppm): 0  
 Chlorine (ppm): 0  
 Surfactants (mg/L): 0.25  
 DO (mg/L): 7.01



Outfall

**Stormwater Outfall Visual Inspection Form**Location I.D.: MA-73037**General Information**

Inspector: Jake LeFeuvre Date & Time: 4/23/2021 10:30:00 AM  
Weather: 40s Sunny Precipitation: <0.1  
Sample Location: Outfall Dry / Wet: Dry  
Last Rain Event: 04/21/21 Land Use: Commercial

**Pipe Information**

Receiving Water: Stormwater Pipe Size (in.): 24  
Pipe Shape: Circle Pipe Material: Concrete  
Pipe Submerged: Yes If Yes - Percent Submerged: 40  
Pipe Notes:

**Observations**

Flow: Yes If Flow - Velocity: Moderate  
Deposits or Stains: Sediment Sediment Depth (% of pipe): 10  
Other Deposits: \_\_\_\_\_ Sedimentation: Yes  
Vegetation: No Scouring: No  
Flow Source: City Visual Evidence of Illicit Discharge: Yes  
Comments:

**Sample Information - Field Parameters**

Sample Taken: Yes If No - Reason: \_\_\_\_\_  
Odor: None Clarity: \_\_\_\_\_ Turbidity (visual): Clear (1.69)  
Temperature (°C): 10.5 Color: None  
Conductivity (mS/cm): 0.464  
pH: 6.71  
Salinity (ppt): 0.22  
Ammonia (ppm): 0  
Chlorine (ppm): 0  
Surfactants (mg/L): 0.25  
DO (mg/L): 8.99



Outfall



## ANALYTICAL REPORT

Lab Number:	L2120861
Client:	EST Associates, Inc. 124 Crescent Road Needham, MA 02494
ATTN:	John D'Andrea
Phone:	(781) 455-0003
Project Name:	MS4 OUTFALL INSPECTIONS & SAMP
Project Number:	TOWN OF FOXBOROUGH
Report Date:	05/05/21

The original project report/data package is held by Alpha Analytical. This report/data package is paginated and should be reproduced only in its entirety. Alpha Analytical holds no responsibility for results and/or data that are not consistent with the original.

Certifications & Approvals: MA (M-MA086), NH NELAP (2064), CT (PH-0574), IL (200077), ME (MA00086), MD (348), NJ (MA935), NY (11148), NC (25700/666), PA (68-03671), RI (LAO00065), TX (T104704476), VT (VT-0935), VA (460195), USDA (Permit #P330-17-00196).

---

Eight Walkup Drive, Westborough, MA 01581-1019  
508-898-9220 (Fax) 508-898-9193 800-624-9220 - [www.alphalab.com](http://www.alphalab.com)



**Project Name:** MS4 OUTFALL INSPECTIONS & SAMP  
**Project Number:** TOWN OF FOXBOROUGH

**Lab Number:** L2120861  
**Report Date:** 05/05/21

<b>Alpha Sample ID</b>	<b>Client ID</b>	<b>Matrix</b>	<b>Sample Location</b>	<b>Collection Date/Time</b>	<b>Receive Date</b>
L2120861-01	16-02	WATER	70 ELM STREET, FOXBOROUGH, MA	04/23/21 08:15	04/23/21
L2120861-02	17-07	WATER	70 ELM STREET, FOXBOROUGH, MA	04/23/21 09:15	04/23/21
L2120861-03	20-18	WATER	70 ELM STREET, FOXBOROUGH, MA	04/23/21 12:35	04/23/21
L2120861-04	15-03	WATER	70 ELM STREET, FOXBOROUGH, MA	04/23/21 11:45	04/23/21
L2120861-05	19-11	WATER	70 ELM STREET, FOXBOROUGH, MA	04/23/21 12:05	04/23/21
L2120861-06	02-08	WATER	70 ELM STREET, FOXBOROUGH, MA	04/23/21 11:05	04/23/21
L2120861-07	AUID MA62009	WATER	70 ELM STREET, FOXBOROUGH, MA	04/23/21 09:50	04/23/21
L2120861-08	AUID MA73037	WATER	70 ELM STREET, FOXBOROUGH, MA	04/23/21 10:30	04/23/21

**Project Name:** MS4 OUTFALL INSPECTIONS & SAMP  
**Project Number:** TOWN OF FOXBOROUGH

**Lab Number:** L2120861  
**Report Date:** 05/05/21

### Case Narrative

The samples were received in accordance with the Chain of Custody and no significant deviations were encountered during the preparation or analysis unless otherwise noted. Sample Receipt, Container Information, and the Chain of Custody are located at the back of the report.

Results contained within this report relate only to the samples submitted under this Alpha Lab Number and meet NELAP requirements for all NELAP accredited parameters unless otherwise noted in the following narrative. The data presented in this report is organized by parameter (i.e. VOC, SVOC, etc.). Sample specific Quality Control data (i.e. Surrogate Spike Recovery) is reported at the end of the target analyte list for each individual sample, followed by the Laboratory Batch Quality Control at the end of each parameter. Tentatively Identified Compounds (TICs), if requested, are reported for compounds identified to be present and are not part of the method/program Target Compound List, even if only a subset of the TCL are being reported. If a sample was re-analyzed or re-extracted due to a required quality control corrective action and if both sets of data are reported, the Laboratory ID of the re-analysis or re-extraction is designated with an "R" or "RE", respectively.

When multiple Batch Quality Control elements are reported (e.g. more than one LCS), the associated samples for each element are noted in the grey shaded header line of each data table. Any Laboratory Batch, Sample Specific % recovery or RPD value that is outside the listed Acceptance Criteria is bolded in the report. In reference to questions H (CAM) or 4 (RCP) when "NO" is checked, the performance criteria for CAM and RCP methods allow for some quality control failures to occur and still be within method compliance. In these instances, the specific failure is not narrated but noted in the associated QC Outlier Summary Report, located directly after the Case Narrative. QC information is also incorporated in the Data Usability Assessment table (Format 11) of our Data Merger tool, where it can be reviewed in conjunction with the sample result, associated regulatory criteria and any associated data usability implications.

Soil/sediments, solids and tissues are reported on a dry weight basis unless otherwise noted. Definitions of all data qualifiers and acronyms used in this report are provided in the Glossary located at the back of the report.

**HOLD POLICY** - For samples submitted on hold, Alpha's policy is to hold samples (with the exception of Air canisters) free of charge for 21 calendar days from the date the project is completed. After 21 calendar days, we will dispose of all samples submitted including those put on hold unless you have contacted your Alpha Project Manager and made arrangements for Alpha to continue to hold the samples. Air canisters will be disposed after 3 business days from the date the project is completed.

Please contact Project Management at 800-624-9220 with any questions.

---



**Project Name:** MS4 OUTFALL INSPECTIONS & SAMP  
**Project Number:** TOWN OF FOXBOROUGH

**Lab Number:** L2120861  
**Report Date:** 05/05/21

**Case Narrative (continued)**

E. Coli (MF)

L2120861-01 through -05, -07 and -08: The sample have an elevated detection limit due to the dilution required by the method.

BOD, 5 day

L2120861-03 was set at the correct dilution for BOD analysis according to prep screening; however, not enough depletion occurred. Therefore, the sample result is reported as "non-detect" at an elevated detection limit. Due to the expiration of the method required holding time, re-analysis could not be performed.

I, the undersigned, attest under the pains and penalties of perjury that, to the best of my knowledge and belief and based upon my personal inquiry of those responsible for providing the information contained in this analytical report, such information is accurate and complete. This certificate of analysis is not complete unless this page accompanies any and all pages of this report.

Authorized Signature:

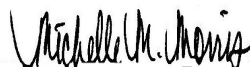

Michelle M. Morris

Title: Technical Director/Representative

Date: 05/05/21

# **INORGANICS & MISCELLANEOUS**

**Project Name:** MS4 OUTFALL INSPECTIONS & SAMP  
**Project Number:** TOWN OF FOXBOROUGH

**Lab Number:** L2120861  
**Report Date:** 05/05/21

### SAMPLE RESULTS

**Lab ID:** L2120861-01  
**Client ID:** 16-02  
**Sample Location:** 70 ELM STREET, FOXBOROUGH, MA

**Date Collected:** 04/23/21 08:15  
**Date Received:** 04/23/21  
**Field Prep:** Not Specified

**Sample Depth:**  
**Matrix:** Water

Parameter	Result	Qualifier	Units	RL	MDL	Dilution Factor	Date Prepared	Date Analyzed	Analytical Method	Analyst
Microbiological Analysis - Westborough Lab										
E. Coli (MF)	ND		col/100ml	2.0	NA	2	-	04/23/21 16:10	121,9213D	JW



**Project Name:** MS4 OUTFALL INSPECTIONS & SAMP  
**Project Number:** TOWN OF FOXBOROUGH

**Lab Number:** L2120861  
**Report Date:** 05/05/21

### SAMPLE RESULTS

**Lab ID:** L2120861-02  
**Client ID:** 17-07  
**Sample Location:** 70 ELM STREET, FOXBOROUGH, MA

**Date Collected:** 04/23/21 09:15  
**Date Received:** 04/23/21  
**Field Prep:** Not Specified

**Sample Depth:**  
**Matrix:** Water

Parameter	Result	Qualifier	Units	RL	MDL	Dilution Factor	Date Prepared	Date Analyzed	Analytical Method	Analyst
<b>Microbiological Analysis - Westborough Lab</b>										
E. Coli (MF)	ND		col/100ml	2.0	NA	2	-	04/23/21 16:10	121,9213D	JW
<b>General Chemistry - Westborough Lab</b>										
Solids, Total Suspended	ND		mg/l	5.0	NA	1	-	04/29/21 09:15	121,2540D	AC



**Project Name:** MS4 OUTFALL INSPECTIONS & SAMP  
**Project Number:** TOWN OF FOXBOROUGH

**Lab Number:** L2120861  
**Report Date:** 05/05/21

**SAMPLE RESULTS**

**Lab ID:** L2120861-03  
**Client ID:** 20-18  
**Sample Location:** 70 ELM STREET, FOXBOROUGH, MA

**Date Collected:** 04/23/21 12:35  
**Date Received:** 04/23/21  
**Field Prep:** Not Specified

**Sample Depth:**  
**Matrix:** Water

Parameter	Result	Qualifier	Units	RL	MDL	Dilution Factor	Date Prepared	Date Analyzed	Analytical Method	Analyst
<b>Microbiological Analysis - Westborough Lab</b>										
E. Coli (MF)	ND		col/100ml	2.0	NA	2	-	04/23/21 16:10	121,9213D	JW
<b>General Chemistry - Westborough Lab</b>										
Phosphorus, Total	0.016		mg/l	0.010	--	1	04/29/21 16:00	04/30/21 12:35	121,4500P-E	SD
BOD, 5 day	ND		mg/l	5.0	NA	2.5	04/23/21 19:30	04/28/21 17:05	121,5210B	JD



**Project Name:** MS4 OUTFALL INSPECTIONS & SAMP  
**Project Number:** TOWN OF FOXBOROUGH

**Lab Number:** L2120861  
**Report Date:** 05/05/21

**SAMPLE RESULTS**

**Lab ID:** L2120861-04  
**Client ID:** 15-03  
**Sample Location:** 70 ELM STREET, FOXBOROUGH, MA

**Date Collected:** 04/23/21 11:45  
**Date Received:** 04/23/21  
**Field Prep:** Not Specified

**Sample Depth:**  
**Matrix:** Water

Parameter	Result	Qualifier	Units	RL	MDL	Dilution Factor	Date Prepared	Date Analyzed	Analytical Method	Analyst
<b>Microbiological Analysis - Westborough Lab</b>										
E. Coli (MF)	ND		col/100ml	2.0	NA	2	-	04/23/21 16:10	121,9213D	JW
<b>General Chemistry - Westborough Lab</b>										
Phosphorus, Total	0.050		mg/l	0.010	--	1	04/29/21 16:00	04/30/21 12:36	121,4500P-E	SD
BOD, 5 day	ND		mg/l	2.0	NA	1	04/23/21 19:30	04/28/21 17:05	121,5210B	JD



**Project Name:** MS4 OUTFALL INSPECTIONS & SAMP  
**Project Number:** TOWN OF FOXBOROUGH

**Lab Number:** L2120861  
**Report Date:** 05/05/21

### SAMPLE RESULTS

**Lab ID:** L2120861-05  
**Client ID:** 19-11  
**Sample Location:** 70 ELM STREET, FOXBOROUGH, MA

**Date Collected:** 04/23/21 12:05  
**Date Received:** 04/23/21  
**Field Prep:** Not Specified

**Sample Depth:**  
**Matrix:** Water

Parameter	Result	Qualifier	Units	RL	MDL	Dilution Factor	Date Prepared	Date Analyzed	Analytical Method	Analyst
<b>Microbiological Analysis - Westborough Lab</b>										
E. Coli (MF)	ND		col/100ml	2.0	NA	2	-	04/23/21 16:10	121,9213D	JW
<b>General Chemistry - Westborough Lab</b>										
Phosphorus, Total	ND		mg/l	0.010	--	1	04/30/21 10:30	05/03/21 12:59	121,4500P-E	SD
BOD, 5 day	ND		mg/l	2.0	NA	1	04/23/21 19:30	04/28/21 17:05	121,5210B	JD



**Project Name:** MS4 OUTFALL INSPECTIONS & SAMP  
**Project Number:** TOWN OF FOXBOROUGH

**Lab Number:** L2120861  
**Report Date:** 05/05/21

**SAMPLE RESULTS**

**Lab ID:** L2120861-06  
**Client ID:** 02-08  
**Sample Location:** 70 ELM STREET, FOXBOROUGH, MA

**Date Collected:** 04/23/21 11:05  
**Date Received:** 04/23/21  
**Field Prep:** Not Specified

**Sample Depth:**  
**Matrix:** Water

Parameter	Result	Qualifier	Units	RL	MDL	Dilution Factor	Date Prepared	Date Analyzed	Analytical Method	Analyst
<b>Microbiological Analysis - Westborough Lab</b>										
E. Coli (MF)	10		col/100ml	2.0	NA	2	-	04/23/21 16:10	121,9213D	JW
<b>General Chemistry - Westborough Lab</b>										
Phosphorus, Total	0.023		mg/l	0.010	--	1	04/30/21 10:30	05/03/21 13:02	121,4500P-E	SD
BOD, 5 day	ND		mg/l	2.0	NA	1	04/23/21 19:30	04/28/21 17:05	121,5210B	JD





**Project Name:** MS4 OUTFALL INSPECTIONS & SAMP  
**Project Number:** TOWN OF FOXBOROUGH

**Lab Number:** L2120861  
**Report Date:** 05/05/21

### SAMPLE RESULTS

**Lab ID:** L2120861-07  
**Client ID:** AUID MA62009  
**Sample Location:** 70 ELM STREET, FOXBOROUGH, MA

**Date Collected:** 04/23/21 09:50  
**Date Received:** 04/23/21  
**Field Prep:** Not Specified

**Sample Depth:**  
**Matrix:** Water

Parameter	Result	Qualifier	Units	RL	MDL	Dilution Factor	Date Prepared	Date Analyzed	Analytical Method	Analyst
Microbiological Analysis - Westborough Lab										
E. Coli (MF)	ND		col/100ml	2.0	NA	2	-	04/23/21 16:10	121,9213D	JW



**Project Name:** MS4 OUTFALL INSPECTIONS & SAMP  
**Project Number:** TOWN OF FOXBOROUGH

**Lab Number:** L2120861  
**Report Date:** 05/05/21

**SAMPLE RESULTS**

**Lab ID:** L2120861-08  
**Client ID:** AUID MA73037  
**Sample Location:** 70 ELM STREET, FOXBOROUGH, MA

**Date Collected:** 04/23/21 10:30  
**Date Received:** 04/23/21  
**Field Prep:** Not Specified

**Sample Depth:**  
**Matrix:** Water

Parameter	Result	Qualifier	Units	RL	MDL	Dilution Factor	Date Prepared	Date Analyzed	Analytical Method	Analyst
<b>Microbiological Analysis - Westborough Lab</b>										
E. Coli (MF)	ND		col/100ml	2.0	NA	2	-	04/23/21 16:10	121,9213D	JW
<b>General Chemistry - Westborough Lab</b>										
Phosphorus, Total	0.078		mg/l	0.010	--	1	04/30/21 10:30	05/03/21 13:03	121,4500P-E	SD
BOD, 5 day	ND		mg/l	2.0	NA	1	04/23/21 19:30	04/28/21 17:05	121,5210B	JD



**Project Name:** MS4 OUTFALL INSPECTIONS & SAMF  
**Project Number:** TOWN OF FOXBOROUGH

**Lab Number:** L2120861  
**Report Date:** 05/05/21

**Method Blank Analysis**  
**Batch Quality Control**

Parameter	Result	Qualifier	Units	RL	MDL	Dilution Factor	Date Prepared	Date Analyzed	Analytical Method	Analyst
General Chemistry - Westborough Lab for sample(s): 03-06,08 Batch: WG1490077-1										
BOD, 5 day	ND		mg/l	2.0	NA	1	04/23/21 19:30	04/28/21 17:05	121,5210B	JD
Microbiological Analysis - Westborough Lab for sample(s): 01-08 Batch: WG1490093-1										
E. Coli (MF)	ND		col/100ml	1.0	NA	1	-	04/23/21 16:10	121,9213D	JW
General Chemistry - Westborough Lab for sample(s): 02 Batch: WG1492215-1										
Solids, Total Suspended	ND		mg/l	5.0	NA	1	-	04/29/21 09:15	121,2540D	AC
General Chemistry - Westborough Lab for sample(s): 03-04 Batch: WG1492374-1										
Phosphorus, Total	ND		mg/l	0.010	--	1	04/29/21 16:00	04/30/21 12:15	121,4500P-E	SD
General Chemistry - Westborough Lab for sample(s): 05-06,08 Batch: WG1492725-1										
Phosphorus, Total	ND		mg/l	0.010	--	1	04/30/21 10:30	05/03/21 12:54	121,4500P-E	SD

**Lab Control Sample Analysis****Batch Quality Control****Project Name:** MS4 OUTFALL INSPECTIONS & SAMP**Lab Number:** L2120861**Project Number:** TOWN OF FOXBOROUGH**Report Date:** 05/05/21

<b>Parameter</b>	<b>LCS %Recovery</b>	<b>Qual</b>	<b>LCSD %Recovery</b>	<b>Qual</b>	<b>%Recovery Limits</b>	<b>RPD</b>	<b>Qual</b>	<b>RPD Limits</b>
<b>General Chemistry - Westborough Lab Associated sample(s): 03-06,08 Batch: WG1490077-2</b>								
BOD, 5 day	96		-		85-115	-		20
<b>General Chemistry - Westborough Lab Associated sample(s): 02 Batch: WG1492215-2</b>								
Solids, Total Suspended	103		-		80-120	-		
<b>General Chemistry - Westborough Lab Associated sample(s): 03-04 Batch: WG1492374-2</b>								
Phosphorus, Total	99		-		80-120	-		
<b>General Chemistry - Westborough Lab Associated sample(s): 05-06,08 Batch: WG1492725-2</b>								
Phosphorus, Total	103		-		80-120	-		

### Matrix Spike Analysis Batch Quality Control

**Project Name:** MS4 OUTFALL INSPECTIONS & SAMP  
**Project Number:** TOWN OF FOXBOROUGH

**Lab Number:** L2120861  
**Report Date:** 05/05/21

Parameter	Native Sample	MS Added	MS Found	MS %Recovery	MSD Qual	MSD Found	MSD %Recovery	MSD Qual	Recovery Limits	RPD	RPD Qual	RPD Limits
General Chemistry - Westborough Lab Associated sample(s): 03-06,08 QC Batch ID: WG1490077-4 QC Sample: L2120827-02 Client ID: MS Sample												
BOD, 5 day	ND	100	100	101	-	-	-	-	50-145	-	-	35
General Chemistry - Westborough Lab Associated sample(s): 03-04 QC Batch ID: WG1492374-4 QC Sample: L2121724-01 Client ID: MS Sample												
Phosphorus, Total	0.039	0.5	0.547	102	-	-	-	-	75-125	-	-	20
General Chemistry - Westborough Lab Associated sample(s): 05-06,08 QC Batch ID: WG1492725-3 QC Sample: L2120861-05 Client ID: 19-11												
Phosphorus, Total	ND	0.5	0.498	100	-	-	-	-	75-125	-	-	20

## Lab Duplicate Analysis

*Batch Quality Control*

**Project Name:** MS4 OUTFALL INSPECTIONS & SAMP

**Project Number:** TOWN OF FOXBOROUGH

**Lab Number:** L2120861

**Report Date:** 05/05/21

Parameter	Native Sample	Duplicate Sample	Units	RPD	Qual	RPD Limits
General Chemistry - Westborough Lab Associated sample(s): 03-06,08 QC Batch ID: WG1490077-3 QC Sample: L2120827-02 Client ID: DUP Sample						
BOD, 5 day	ND	ND	mg/l	NC		35
General Chemistry - Westborough Lab Associated sample(s): 02 QC Batch ID: WG1492215-3 QC Sample: L2120785-01 Client ID: DUP Sample						
Solids, Total Suspended	29	35	mg/l	19		29
General Chemistry - Westborough Lab Associated sample(s): 03-04 QC Batch ID: WG1492374-3 QC Sample: L2121724-01 Client ID: DUP Sample						
Phosphorus, Total	0.039	0.045	mg/l	14		20
General Chemistry - Westborough Lab Associated sample(s): 05-06,08 QC Batch ID: WG1492725-4 QC Sample: L2120861-05 Client ID: 19-11						
Phosphorus, Total	ND	ND	mg/l	NC		20

**Project Name:** MS4 OUTFALL INSPECTIONS & SAMP**Lab Number:** L2120861**Project Number:** TOWN OF FOXBOROUGH**Report Date:** 05/05/21**Sample Receipt and Container Information**

Were project specific reporting limits specified?

YES

**Cooler Information**

Cooler	Custody Seal
A	Absent

**Container Information**

Container ID	Container Type	Cooler	Initial pH	Final pH	Temp deg C	Pres	Seal	Frozen Date/Time	Analysis(*)
L2120861-01A	Bacteria Cup Na2S2O3 preserved	A	NA		3.7	Y	Absent		E-COLI-MF(.33)
L2120861-01B	Bacteria Cup Na2S2O3 preserved	A	NA		3.7	Y	Absent		E-COLI-MF(.33)
L2120861-02A	Bacteria Cup Na2S2O3 preserved	A	NA		3.7	Y	Absent		E-COLI-MF(.33)
L2120861-02B	Bacteria Cup Na2S2O3 preserved	A	NA		3.7	Y	Absent		E-COLI-MF(.33)
L2120861-02C	Plastic 950ml unpreserved	A	7	7	3.7	Y	Absent		TSS-2540(7)
L2120861-03A	Bacteria Cup Na2S2O3 preserved	A	NA		3.7	Y	Absent		E-COLI-MF(.33)
L2120861-03B	Bacteria Cup Na2S2O3 preserved	A	NA		3.7	Y	Absent		E-COLI-MF(.33)
L2120861-03C	Plastic 250ml H2SO4 preserved	A	<2	<2	3.7	Y	Absent		TPHOS-4500(28)
L2120861-03D	Plastic 500ml unpreserved	A	7	7	3.7	Y	Absent		BOD-5210(2)
L2120861-04A	Bacteria Cup Na2S2O3 preserved	A	NA		3.7	Y	Absent		E-COLI-MF(.33)
L2120861-04B	Bacteria Cup Na2S2O3 preserved	A	NA		3.7	Y	Absent		E-COLI-MF(.33)
L2120861-04C	Plastic 250ml H2SO4 preserved	A	<2	<2	3.7	Y	Absent		TPHOS-4500(28)
L2120861-04D	Plastic 500ml unpreserved	A	7	7	3.7	Y	Absent		BOD-5210(2)
L2120861-05A	Bacteria Cup Na2S2O3 preserved	A	NA		3.7	Y	Absent		E-COLI-MF(.33)
L2120861-05B	Bacteria Cup Na2S2O3 preserved	A	NA		3.7	Y	Absent		E-COLI-MF(.33)
L2120861-05C	Plastic 250ml H2SO4 preserved	A	<2	<2	3.7	Y	Absent		TPHOS-4500(28)
L2120861-05D	Plastic 500ml unpreserved	A	7	7	3.7	Y	Absent		BOD-5210(2)
L2120861-06A	Bacteria Cup Na2S2O3 preserved	A	NA		3.7	Y	Absent		E-COLI-MF(.33)
L2120861-06B	Bacteria Cup Na2S2O3 preserved	A	NA		3.7	Y	Absent		E-COLI-MF(.33)
L2120861-06C	Plastic 250ml H2SO4 preserved	A	<2	<2	3.7	Y	Absent		TPHOS-4500(28)
L2120861-06D	Plastic 500ml unpreserved	A	7	7	3.7	Y	Absent		BOD-5210(2)
L2120861-07A	Bacteria Cup Na2S2O3 preserved	A	NA		3.7	Y	Absent		E-COLI-MF(.33)
L2120861-07B	Bacteria Cup Na2S2O3 preserved	A	NA		3.7	Y	Absent		E-COLI-MF(.33)

**Project Name:** MS4 OUTFALL INSPECTIONS & SAMP**Lab Number:** L2120861**Project Number:** TOWN OF FOXBOROUGH**Report Date:** 05/05/21**Container Information**

<b>Container ID</b>	<b>Container Type</b>	<b>Cooler</b>	<b>Initial pH</b>	<b>Final pH</b>	<b>Temp deg C</b>	<b>Pres</b>	<b>Seal</b>	<b>Frozen Date/Time</b>	<b>Analysis(*)</b>
L2120861-08A	Bacteria Cup Na2S2O3 preserved	A	NA		3.7	Y	Absent		E-COLI-MF(.33)
L2120861-08B	Bacteria Cup Na2S2O3 preserved	A	NA		3.7	Y	Absent		E-COLI-MF(.33)
L2120861-08C	Plastic 250ml H2SO4 preserved	A	<2	<2	3.7	Y	Absent		TPHOS-4500(28)
L2120861-08D	Plastic 500ml unpreserved	A	7	7	3.7	Y	Absent		BOD-5210(2)



**Project Name:** MS4 OUTFALL INSPECTIONS & SAMP  
**Project Number:** TOWN OF FOXBOROUGH

**Lab Number:** L2120861  
**Report Date:** 05/05/21

## GLOSSARY

### Acronyms

DL	- Detection Limit: This value represents the level to which target analyte concentrations are reported as estimated values, when those target analyte concentrations are quantified below the limit of quantitation (LOQ). The DL includes any adjustments from dilutions, concentrations or moisture content, where applicable. (DoD report formats only.)
EDL	- Estimated Detection Limit: This value represents the level to which target analyte concentrations are reported as estimated values, when those target analyte concentrations are quantified below the reporting limit (RL). The EDL includes any adjustments from dilutions, concentrations or moisture content, where applicable. The use of EDLs is specific to the analysis of PAHs using Solid-Phase Microextraction (SPME).
EMPC	- Estimated Maximum Possible Concentration: The concentration that results from the signal present at the retention time of an analyte when the ions meet all of the identification criteria except the ion abundance ratio criteria. An EMPC is a worst-case estimate of the concentration.
EPA	- Environmental Protection Agency.
LCS	- Laboratory Control Sample: A sample matrix, free from the analytes of interest, spiked with verified known amounts of analytes or a material containing known and verified amounts of analytes.
LCSD	- Laboratory Control Sample Duplicate: Refer to LCS.
LFB	- Laboratory Fortified Blank: A sample matrix, free from the analytes of interest, spiked with verified known amounts of analytes or a material containing known and verified amounts of analytes.
LOD	- Limit of Detection: This value represents the level to which a target analyte can reliably be detected for a specific analyte in a specific matrix by a specific method. The LOD includes any adjustments from dilutions, concentrations or moisture content, where applicable. (DoD report formats only.)
LOQ	- Limit of Quantitation: The value at which an instrument can accurately measure an analyte at a specific concentration. The LOQ includes any adjustments from dilutions, concentrations or moisture content, where applicable. (DoD report formats only.)  Limit of Quantitation: The value at which an instrument can accurately measure an analyte at a specific concentration. The LOQ includes any adjustments from dilutions, concentrations or moisture content, where applicable. (DoD report formats only.)
MDL	- Method Detection Limit: This value represents the level to which target analyte concentrations are reported as estimated values, when those target analyte concentrations are quantified below the reporting limit (RL). The MDL includes any adjustments from dilutions, concentrations or moisture content, where applicable.
MS	- Matrix Spike Sample: A sample prepared by adding a known mass of target analyte to a specified amount of matrix sample for which an independent estimate of target analyte concentration is available. For Method 332.0, the spike recovery is calculated using the native concentration, including estimated values.
MSD	- Matrix Spike Sample Duplicate: Refer to MS.
NA	- Not Applicable.
NC	- Not Calculated: Term is utilized when one or more of the results utilized in the calculation are non-detect at the parameter's reporting unit.
NDPA/DPA	- N-Nitrosodiphenylamine/Diphenylamine.
NI	- Not Ignitable.
NP	- Non-Plastic: Term is utilized for the analysis of Atterberg Limits in soil.
NR	- No Results: Term is utilized when 'No Target Compounds Requested' is reported for the analysis of Volatile or Semivolatile Organic TIC only requests.
RL	- Reporting Limit: The value at which an instrument can accurately measure an analyte at a specific concentration. The RL includes any adjustments from dilutions, concentrations or moisture content, where applicable.
RPD	- Relative Percent Difference: The results from matrix and/or matrix spike duplicates are primarily designed to assess the precision of analytical results in a given matrix and are expressed as relative percent difference (RPD). Values which are less than five times the reporting limit for any individual parameter are evaluated by utilizing the absolute difference between the values; although the RPD value will be provided in the report.
SRM	- Standard Reference Material: A reference sample of a known or certified value that is of the same or similar matrix as the associated field samples.
STLP	- Semi-dynamic Tank Leaching Procedure per EPA Method 1315.
TEF	- Toxic Equivalency Factors: The values assigned to each dioxin and furan to evaluate their toxicity relative to 2,3,7,8-TCDD.
TEQ	- Toxic Equivalent: The measure of a sample's toxicity derived by multiplying each dioxin and furan by its corresponding TEF and then summing the resulting values.
TIC	- Tentatively Identified Compound: A compound that has been identified to be present and is not part of the target compound list (TCL) for the method and/or program. All TICs are qualitatively identified and reported as estimated concentrations.

Report Format: Data Usability Report



**Project Name:** MS4 OUTFALL INSPECTIONS & SAMP  
**Project Number:** TOWN OF FOXBOROUGH

**Lab Number:** L2120861  
**Report Date:** 05/05/21

#### Footnotes

- 1 - The reference for this analyte should be considered modified since this analyte is absent from the target analyte list of the original method.

#### Terms

**Analytical Method:** Both the document from which the method originates and the analytical reference method. (Example: EPA 8260B is shown as 1,8260B.) The codes for the reference method documents are provided in the References section of the Addendum.

**Difference:** With respect to Total Oxidizable Precursor (TOP) Assay analysis, the difference is defined as the Post-Treatment value minus the Pre-Treatment value.

**Final pH:** As it pertains to Sample Receipt & Container Information section of the report, Final pH reflects pH of container determined after adjustment at the laboratory, if applicable. If no adjustment required, value reflects Initial pH.

**Frozen Date/Time:** With respect to Volatile Organics in soil, Frozen Date/Time reflects the date/time at which associated Reagent Water-preserved vials were initially frozen. Note: If frozen date/time is beyond 48 hours from sample collection, value will be reflected in 'bold'.

**Initial pH:** As it pertains to Sample Receipt & Container Information section of the report, Initial pH reflects pH of container determined upon receipt, if applicable.

**PAH Total:** With respect to Alkylated PAH analyses, the 'PAHs, Total' result is defined as the summation of results for all or a subset of the following compounds: Naphthalene, C1-C4 Naphthalenes, 2-Methylnaphthalene, 1-Methylnaphthalene, Biphenyl, Acenaphthylene, Acenaphthene, Fluorene, C1-C3 Fluorenes, Phenanthrene, C1-C4 Phenanthrenes/Anthracenes, Anthracene, Fluoranthene, Pyrene, C1-C4 Fluoranthenes/Pyrenes, Benz(a)anthracene, Chrysene, C1-C4 Chrysenes, Benzo(b)fluoranthene, Benzo(j)+(k)fluoranthene, Benzo(e)pyrene, Benzo(a)pyrene, Perylene, Indeno(1,2,3-cd)pyrene, Dibenz(ah)+(ac)anthracene, Benzo(g,h,i)perylene. If a 'Total' result is requested, the results of its individual components will also be reported.

**PFAS Total:** With respect to PFAS analyses, the 'PFAS, Total (5)' result is defined as the summation of results for: PFHpA, PFHxS, PFOA, PFNA and PFOS. In addition, the 'PFAS, Total (6)' result is defined as the summation of results at or above the RL for: PFHpA, PFHxS, PFOA, PFNA, PFDA and PFOS. (Note: 'PFAS, Total (6)' is applicable to MassDEP DW compliance analysis only.). If a 'Total' result is requested, the results of its individual components will also be reported.

The target compound Chlordane (CAS No. 57-74-9) is reported for GC ECD analyses. Per EPA, this compound "refers to a mixture of chlordane isomers, other chlorinated hydrocarbons and numerous other components." (Reference: USEPA Toxicological Review of Chlordane, In Support of Summary Information on the Integrated Risk Information System (IRIS), December 1997.)

**Total:** With respect to Organic analyses, a 'Total' result is defined as the summation of results for individual isomers or Aroclors. If a 'Total' result is requested, the results of its individual components will also be reported. This is applicable to 'Total' results for methods 8260, 8081 and 8082.

#### Data Qualifiers

- A** - Spectra identified as "Aldol Condensates" are byproducts of the extraction/concentration procedures when acetone is introduced in the process.
- B** - The analyte was detected above the reporting limit in the associated method blank. Flag only applies to associated field samples that have detectable concentrations of the analyte at less than ten times (10x) the concentration found in the blank. For MCP-related projects, flag only applies to associated field samples that have detectable concentrations of the analyte at less than ten times (10x) the concentration found in the blank. For DOD-related projects, flag only applies to associated field samples that have detectable concentrations of the analyte at less than ten times (10x) the concentration found in the blank AND the analyte was detected above one-half the reporting limit (or above the reporting limit for common lab contaminants) in the associated method blank. For NJ-Air-related projects, flag only applies to associated field samples that have detectable concentrations of the analyte above the reporting limit. For NJ-related projects (excluding Air), flag only applies to associated field samples that have detectable concentrations of the analyte, which was detected above the reporting limit in the associated method blank or above five times the reporting limit for common lab contaminants (Phthalates, Acetone, Methylene Chloride, 2-Butanone).
- C** - Co-elution: The target analyte co-elutes with a known lab standard (i.e. surrogate, internal standards, etc.) for co-extracted analyses.
- D** - Concentration of analyte was quantified from diluted analysis. Flag only applies to field samples that have detectable concentrations of the analyte.
- E** - Concentration of analyte exceeds the range of the calibration curve and/or linear range of the instrument.
- F** - The ratio of quantifier ion response to qualifier ion response falls outside of the laboratory criteria. Results are considered to be an estimated maximum concentration.
- G** - The concentration may be biased high due to matrix interferences (i.e. co-elution) with non-target compound(s). The result should be considered estimated.
- H** - The analysis of pH was performed beyond the regulatory-required holding time of 15 minutes from the time of sample collection.
- I** - The lower value for the two columns has been reported due to obvious interference.
- J** - Estimated value. This represents an estimated concentration for Tentatively Identified Compounds (TICs).
- M** - Reporting Limit (RL) exceeds the MCP CAM Reporting Limit for this analyte.
- ND** - Not detected at the reporting limit (RL) for the sample.
- NJ** - Presumptive evidence of compound. This represents an estimated concentration for Tentatively Identified Compounds (TICs), where

Report Format: Data Usability Report



**Project Name:** MS4 OUTFALL INSPECTIONS & SAMP  
**Project Number:** TOWN OF FOXBOROUGH

**Lab Number:** L2120861  
**Report Date:** 05/05/21

**Data Qualifiers**

the identification is based on a mass spectral library search.

- P** - The RPD between the results for the two columns exceeds the method-specified criteria.
- Q** - The quality control sample exceeds the associated acceptance criteria. For DOD-related projects, LCS and/or Continuing Calibration Standard exceedences are also qualified on all associated sample results. Note: This flag is not applicable for matrix spike recoveries when the sample concentration is greater than 4x the spike added or for batch duplicate RPD when the sample concentrations are less than 5x the RL. (Metals only.)
- R** - Analytical results are from sample re-analysis.
- RE** - Analytical results are from sample re-extraction.
- S** - Analytical results are from modified screening analysis.

**Project Name:** MS4 OUTFALL INSPECTIONS & SAMP  
**Project Number:** TOWN OF FOXBOROUGH

**Lab Number:** L2120861  
**Report Date:** 05/05/21

## REFERENCES

- 121 Standard Methods for the Examination of Water and Wastewater. APHA-AWWA-WEF. Standard Methods Online.

## LIMITATION OF LIABILITIES

Alpha Analytical performs services with reasonable care and diligence normal to the analytical testing laboratory industry. In the event of an error, the sole and exclusive responsibility of Alpha Analytical shall be to re-perform the work at it's own expense. In no event shall Alpha Analytical be held liable for any incidental, consequential or special damages, including but not limited to, damages in any way connected with the use of, interpretation of, information or analysis provided by Alpha Analytical.

We strongly urge our clients to comply with EPA protocol regarding sample volume, preservation, cooling, containers, sampling procedures, holding time and splitting of samples in the field.



## Certification Information

---

The following analytes are not included in our Primary NELAP Scope of Accreditation:

### Westborough Facility

**EPA 624/624.1:** m/p-xylene, o-xylene, Naphthalene

**EPA 625/625.1:** alpha-Terpineol

**EPA 8260C/8260D:** NPW: 1,2,4,5-Tetramethylbenzene; 4-Ethyltoluene, Azobenzene; SCM: Iodomethane (methyl iodide), 1,2,4,5-Tetramethylbenzene; 4-Ethyltoluene.

**EPA 8270D/8270E:** NPW: Dimethylnaphthalene, 1,4-Diphenylhydrazine, alpha-Terpineol; SCM: Dimethylnaphthalene, 1,4-Diphenylhydrazine.

**SM4500:** NPW: Amenable Cyanide; SCM: Total Phosphorus, TKN, NO<sub>2</sub>, NO<sub>3</sub>.

### Mansfield Facility

**SM 2540D:** TSS

**EPA 8082A:** NPW: PCB: 1, 5, 31, 87, 101, 110, 141, 151, 153, 180, 183, 187.

**EPA TO-15:** Halothane, 2,4,4-Trimethyl-2-pentene, 2,4,4-Trimethyl-1-pentene, Thiophene, 2-Methylthiophene,

3-Methylthiophene, 2-Ethylthiophene, 1,2,3-Trimethylbenzene, Indan, Indene, 1,2,4,5-Tetramethylbenzene, Benzothiophene, 1-Methylnaphthalene.

**Biological Tissue Matrix:** EPA 3050B

---

The following analytes are included in our Massachusetts DEP Scope of Accreditation

### Westborough Facility:

#### Drinking Water

**EPA 300.0:** Chloride, Nitrate-N, Fluoride, Sulfate; **EPA 353.2:** Nitrate-N, Nitrite-N; **SM4500NO3-F:** Nitrate-N, Nitrite-N; **SM4500F-C, SM4500CN-CE,**

**EPA 180.1, SM2130B, SM4500CI-D, SM2320B, SM2540C, SM4500H-B, SM4500NO2-B**

**EPA 332:** Perchlorate; **EPA 524.2:** THMs and VOCs; **EPA 504.1:** EDB, DBCP.

**Microbiology:** **SM9215B; SM9223-P/A, SM9223B-Colilert-QT, SM9222D.**

#### Non-Potable Water

**SM4500H,B, EPA 120.1, SM2510B, SM2540C, SM2320B, SM4500CL-E, SM4500F-BC, SM4500NH3-BH:** Ammonia-N and Kjeldahl-N, **EPA 350.1:**

Ammonia-N, **LCHAT 10-107-06-1-B:** Ammonia-N, **EPA 351.1, SM4500NO3-F, EPA 353.2:** Nitrate-N, **SM4500P-E, SM4500P-B, E, SM4500SO4-E,**

**SM5220D, EPA 410.4, SM5210B, SM5310C, SM4500CL-D, EPA 1664, EPA 420.1, SM4500-CN-CE, SM2540D, EPA 300:** Chloride, Sulfate, Nitrate.

**EPA 624.1:** Volatile Halocarbons & Aromatics,

**EPA 608.3:** Chlordane, Toxaphene, Aldrin, alpha-BHC, beta-BHC, gamma-BHC, delta-BHC, Dieldrin, DDD, DDE, DDT, Endosulfan I, Endosulfan II,

Endosulfan sulfate, Endrin, Endrin Aldehyde, Heptachlor, Heptachlor Epoxide, PCBs

**EPA 625.1:** SVOC (Acid/Base/Neutral Extractables), **EPA 600/4-81-045:** PCB-Oil.

**Microbiology:** **SM9223B-Colilert-QT; Enterolert-QT, SM9221E, EPA 1600, EPA 1603, SM9222D.**

### Mansfield Facility:

#### Drinking Water

**EPA 200.7:** Al, Ba, Cd, Cr, Cu, Fe, Mn, Ni, Na, Ag, Ca, Zn. **EPA 200.8:** Al, Sb, As, Ba, Be, Cd, Cr, Cu, Pb, Mn, Ni, Se, Ag, TL, Zn. **EPA 245.1 Hg.**

**EPA 522, EPA 537.1.**

#### Non-Potable Water

**EPA 200.7:** Al, Sb, As, Be, Cd, Ca, Cr, Co, Cu, Fe, Pb, Mg, Mn, Mo, Ni, K, Se, Ag, Na, Sr, TL, Ti, V, Zn.

**EPA 200.8:** Al, Sb, As, Be, Cd, Cr, Cu, Fe, Pb, Mn, Ni, K, Se, Ag, Na, TL, Zn.

**EPA 245.1 Hg.**

**SM2340B**

---

For a complete listing of analytes and methods, please contact your Alpha Project Manager.



## **Appendix J**

# **Report on Impervious Area and Green Infrastructure Practices**





## Supporting LID in Your Community

### How to Compare Local Land Use Regulations with Best Practices

#### Key Areas of Analysis

The following analysis framework is designed to assist communities in Massachusetts in applying cost-effective Low Impact Development (LID) techniques. Specifically, this template enables you to evaluate local land use regulations in relation to models and examples from the Commonwealth of Massachusetts’ Smart Growth/Smart Energy Toolkit and other sources in relation to the use of LID and Green Infrastructure (GI) techniques. The focus is primarily on residential development, but the concepts are also applicable to other forms of development and redevelopment.

Best practices minimize the alteration of natural green infrastructure such as forests; reduce creation of impervious surfaces; support retention of naturally vegetated buffers along wetlands and waterways; minimize grading and alterations to natural flow patterns; and support the use of LID techniques as the preferred, most easily permitted methods for managing stormwater.

Get more details on LID’s many cost-savings and other benefits at: [www.massaudubon.org/LIDCost](http://www.massaudubon.org/LIDCost).

Local coordination across municipal boards and permits is also important for supporting LID. Application of these practices can result in significant savings in infrastructure maintenance costs, as well as improved water quality and protection of water supplies, while supporting property values and overall quality of life. Sustainable development through the application of LID in all aspects of land and water management is a multi-faceted issue that can only successfully be addressed by working together among different departments and perspectives.

#### Key Areas of Analysis

1. **Overall site design:** Open Space Residential Design (OSRD) vs. conventional subdivisions
2. **Project design and layout standards in relation to LID:** road layout and width, curbing, drainage, sidewalks, parking, landscaping
3. **Maintenance and operations, mechanisms for enforcement:** Who is responsible for maintaining drainage/LID (municipal or homeowner); easements, homeowner association option; municipal inspection and administration systems (this is needed regardless of who is responsible)





## Open Space Residential Design (OSRD) Overview

This section reviews how local bylaws for cluster, Open Space Residential Design (OSRD), or Natural Resource Protection Zoning (NRPZ) compare to the state's recommended best practices. Communities may currently have multiple bylaws that cover this in different residential areas, in which case they can each be compared to the model regulations. However, in most cases, we would encourage simplification and the use of a single OSRD bylaw with local priorities clearly defined.

Communities may also have no cluster, OSRD, or NRPZ bylaws on the books. In this case, the state's best practice model (see resources below) can be used to create one. If the community closely follows the model, they'll meet the characteristics described within the analysis. However, the analysis still provides a quick checklist.

Some of the most important aspects of OSRD in any community include: the four-step review process that carefully considers the natural landscape before drawing lot lines; the minimum amount of open space protected; the incorporation of LID practices; and allowing this type of development by right instead of special permit.

## Zoning, Subdivision, Site Plan Review, and Stormwater Overview

This section reviews not only the individual bylaws and regulations, but also how they work together and how consistent they are. Communities often update portions of bylaws or regulations in a piecemeal way over decades, leading to inconsistencies among various provisions. This color-coded analysis provides a quick overview of not only which rules are out of date and not meeting best practices for LID and preservation of Green Infrastructure, but also how certain topics (such as siting of LID) may be inconsistent between different parts of land use rules.

Not all factors (such as road width, siting of LID, limits on clearing and grading, or allowing common drives) may be addressed in each of the sections considered (Zoning bylaws, Subdivision Rules and Regulations, Site Plan Review (SPR), and Stormwater/LID bylaw). Where that factor is not usually included within a regulation or bylaw, you'll notice that "(Not Applicable)" will appear in that box. For example, setbacks and frontage requirements are addressed under Zoning, but often not under other bylaws or regulations. Those boxes are available for editing where desired. The sections identified for review may also need to be adjusted for your analysis, and you may need to add or remove columns to reflect the unique set of bylaws and regulations applicable in your community.

This review may also help towns identify best practices that comply with MS4 permit requirements, issued by EPA and Mass DEP, though it is not comprehensive in relation to the permit requirements and additional actions may be needed. Consultation with EPA and/or DEP is strongly recommended. Visit [www.mass.gov/guides/municipal-compliance-fact-sheet-stormwater](http://www.mass.gov/guides/municipal-compliance-fact-sheet-stormwater) for more info.

The analysis is broken into five goals, each with factors that address the goal:

### **Goal 1: Protect Natural Resources and Open Space**

The focus of this section is to limit clearing and grading and encourage soil management, the use of native species, and revegetation of disturbed areas. Often, communities have language such as "due regard shall be shown for natural features" without any specific limitations or guidelines that can be used by local boards to ensure developers are following the true intent of the community. The retention of natural vegetation and soils is the single most efficient means of reducing development impacts on water resources, avoiding costs associated with piping and other "grey" stormwater management features as well as the need for irrigation. There are also many other benefits – including habitat for birds and pollinators, trees for shade and clean air, and protection of natural scenery that contributes to property values and a high quality of life.

### **Goal 2: Promote Efficient, Compact Development Patterns and Infill**

Often, making dimensional requirements such as setbacks, lot size, and frontage more flexible as well as allowing common drives will help allow the community to encourage efficient, compact designs. These help to decrease the amount of impervious surfaces and increase infiltration, while still supporting new development.

### **Goal 3: Smart Designs that Reduce Overall Imperviousness**

This section reviews site design such as street location, road width, cul-de-sac design, curbing, roadside swales, and sidewalk design and location. There are many opportunities for communities to minimize impervious surfaces and allow for infiltration through curb cuts, swales, and cul-de-sacs with bioretention, among other things.

### **Goal 4: Adopt Green Infrastructure Stormwater Management Provisions**

This section looks to explicitly discuss LID as a preferred method, such as requiring roof runoff to be directed into vegetated areas, and a preference for infiltration wherever soils allow or can be amended. Bylaws and/or regulations should clearly specify what LID is and which BMPs are preferred or required. Communities should also require an operations and maintenance plan to encourage effective use of LID methods. Adopting a specific LID bylaw can help clearly define and incorporate LID as a preferential stormwater management technique. Defining LID within this bylaw also decreases the need to explain LID throughout each of the Zoning bylaws, SPR, and subdivision rules and regulations and reduce the potential for any conflict between regulations and bylaws. This section also includes additional stormwater management considerations relevant to the MS4 permit.

### **Goal 5: Encourage Efficient Parking**

Parking accounts for a large amount of impervious surface within new and redevelopment projects and offers an enormous opportunity for using LID. By reducing the amount of required parking - or even including parking *maximums* instead of *minimums*, communities can drastically reduce their impervious surfaces and runoff. Many communities already require landscaping in parking areas, which also offers an opportunity to allow curb cuts and infiltration in these areas - improving water quality and reducing the need for irrigation.

## Additional Notes and Recommendations

### Stormwater Calculations

Ensure your regulations reference the most updated data on storm intensities from the Northeast Climate Center at <http://www.nrcc.cornell.edu/>

### Landscaping and Recommended Trees

Ensure your local landscaping regulations require native, pollinator friendly species such as those here: [http://www.nrcs.usda.gov/Internet/FSE\\_DOCUMENTS/nrcs144p2\\_015043.pdf](http://www.nrcs.usda.gov/Internet/FSE_DOCUMENTS/nrcs144p2_015043.pdf)

## Additional Considerations

### Funding and Maintenance:

- Ensure sufficient funding for DPW to perform maintenance of stormwater management facilities, whether conventional or LID.
- Consider reduced costs of paving, plowing, salt when comparing LID maintenance costs with conventional designs
- Create mechanisms for enforcement of maintenance agreements; establish regulations/fines for property owners who fail to maintain stormwater facilities.

### Training, Demonstration Projects, and Public Education:

- Provide opportunities for and encourage municipal staff and committee/board members to participate in LID workshops or conferences.
- Implement LID demonstration programs at city or town hall, schools, DPW, etc.

### Nonpotable Uses of Clean Stormwater:

- Local plumbing codes should allow the use of clean (e.g. rooftop) rainwater for landscape irrigation and interior non-potable uses such as toilet flushing.

<b>MA Open Space Residential Design Best Practices Factors</b>	<b>Conventional</b>	<b>Better</b>	<b>Best Practice</b>	<b>Community's OSRD</b>
<b>Permit Type</b>	Special Permit	By Right	Mandatory	Special Permit (Zoning Bylaw Section 275-8.3.2)
<b>Land area to which the zoning is applicable</b>	Only a small amount of developable land	Land of particular environmental sensitivity	All developable land zoned residential	R-40 (which seems to be most developable land in town)
<b>Minimum Open Space</b>	50-65%	65-75%	≥ 75%	minimum of 45%, but could be reduced to 35% depending on circumstances (Zoning Bylaw Section 275-8.3.6)
<b>Yield Calculation</b>	Full plan with full percolation tests	Sketch plan with selected percolation test(s)	By formula	sketch plan with perc tests. (Zoning Bylaw Section 275-8.3.10)
<b>Minimum parcel size</b>	≥ 10 acres	5-10 acres	None	
<b>Review Process</b>	No detailed analysis of site characteristics in relation to design	Cluster layout	Flexible "OSRD" 4 Step	no detailed analysis of site characteristics. (Zoning Bylaw Sections 275-8.3.6 and 8.3.12)
<b>Ownership of Open Space</b>	Appropriate to the resources present. For example, agricultural land by the farmer, watershed land by a water dept. or district, habitat land by the conservation commission, or recreational open space by a parks and recreation commission or homeowners association.			various options. (Zoning Bylaw Section 8.3.7)
<b>Dimensional Standards; area, frontage, etc.</b>	Specified, < than for standard subdivision	Formulaic reduction with specified minimums	None set or small minimums	Minimum specified less than standard subdivision (See Zoning Bylaw Sections 275-8.3.4 and 8.4.2)
<b>Quality of open space conserved: Specificity of local priorities for natural, cultural, and historic resource conservation</b>	No indication of local conservation priorities, or language that refers only to regulated resource areas.	Lack of specificity regarding local conservation priorities; no map of priority locations	Local priorities clearly and unambiguously stated and mapped for use in site design.	No local conservation priorities. (Zoning Bylaw Section 275-8.3.6)

MA Open Space Residential Design Best Practices Factors	Conventional	Better	Best Practice	Community's OSRD
<b>Contiguity of open space; relationship to previously protected open space</b>	No contiguity requirement	Contiguity required within subdivision	Contiguity required; adjacent land considered	No contiguity requirement. (See Zoning Bylaw Section 275-8.3.6)
<b>Quality of open space conserved: Allowed uses of open space</b>	Allowed use of open space not addressed	Vague language regarding use of conserved open space	Clear list of allowed uses consistent with conservation and recreation goals	Language re: permitted uses, but not very specific. (Zoning Bylaw Section 275-8.3.6(2))
<b>Quality of open space conserved: Submission requirements - GIS maps, data, etc. to inform the review process</b>	Vague or no language regarding submission of information on site resources and no specified process for the use of the data submitted	General non-comprehensive data and mapping requirements; vague process for the application of the data to site design and open space conservation	Specific plans, maps, & comprehensive data regarding natural, cultural, and historic resources required and used as the basis for open space conservation	Required to submit information re: site resources, etc., but no detailed application of data to proposal. (See Zoning Bylaw Section 275-8.3.10)
<b>Relationship to Plans</b>	Relationship to plans not discussed	Optional consideration of open space goals of OSRP, master, and/or regional policy plan	Required consideration of open space goals of OSRP, master, and/or regional policy plan	No relationship to town plans mentioned.
<b>Low Impact Design</b>	Not addressed	Encouraged	Required	not addressed.
<b>Density bonus for enhanced public benefit(s)</b>	No bonus offered	Bonus by special permit	Automatic or formulaic bonus	no bonus offered
<b>Review Entity</b>	ZBA, council or selectmen as special permit authority	Planning Board	Planning Board	Planning Board (Zoning Bylaw Section 275-8.3.2)
<b>Flexibility re: open space protection to facilitate wastewater treatment facilities</b>	No flexibility provided	Aggregate calculations allowed by board of health	If necessary, required open space may be reduced by < 10% to accommodate; disposal area deed restricted; aggregate calculations allowed by BoH, etc.	No flexibility provided

<b>MA Open Space Residential Design Best Practices Factors</b>	<b>Conventional</b>	<b>Better</b>	<b>Best Practice</b>	<b>Community's OSRD</b>
<b>Monitoring of open space</b>	No specified monitoring requirements and no requirements that would assist the party responsible for monitoring	Loose provisions to facilitate, municipal monitoring, or no specificity regarding monitoring interval	Specific provisions to aid endowed monitoring by a conservation org at stated intervals	no specified monitoring requirements.

Factors	Conventional	Better	Best	Community's Zoning	Community's Subdivision Rules & Regulations	Community's Site Plan Review	Community's Stormwater/LID Bylaw/Regulations
<b>GOAL 1: PROTECT NATURAL RESOURCES AND OPEN SPACE</b>							
Soils managed for revegetation	Not addressed	Limitations on removal from site, and/or requirements for stabilization and revegetation	Prohibit removal of topsoil from site. Require prep of soils compacted during construction	(Not applicable)	Not addressed	Not addressed	Not addressed
Limit clearing, lawn size, require retention or planting of native vegetation/naturalized areas	Not addressed or general qualitative statement not tied to other design standards	Encourage minimization of clearing/ grubbing	Require minimization of clearing/grubbing with specific standards	Preservation of natural lanscape with minimization of soil removal and clearing as much as practicable. (Zoning Bylaw Section 6.5.2); Clearing restricted for solar energy installations. (Zoning Bylaw Section 7.4.5(6)); clearing restricted in Special Use District (Zoning Bylaw Section 9.1.5(5))	Not addressed	not addressed	Not addressed
Require native vegetation and trees	Require or recommend invasives	Not addressed, or mixture of required plantings of native and nonnative	Require at least 75% native plantings	Not specified.	Shade trees along streets must be native. Species. (Subdivision Regs Section 5.06(B))	not addressed	Not addressed

Factors	Conventional	Better	Best	Community's Zoning	Community's Subdivision Rules & Regulations	Community's Site Plan Review	Community's Stormwater/LID Bylaw/Regulations
<b>GOAL 2: PROMOTE EFFICIENT, COMPACT DEVELOPMENT PATTERNS AND INFILL</b>							
Lot size	Required minimum lot sizes	OSRD/NRPZ preferred. Special permit with incentives to utilize	Flexible with OSRD/NRPZ by right, preferred option	required minimums (Zoning Bylaw Section 4.1) OSRD by special permit. (Zoning Bylaw Section 8.3.2)	(Not applicable)	(Not applicable)	(Not applicable)
Housing density	Multi-family housing not allowed, or only in/adjacent to commercial and industrial uses	Multi-family and cluster developments allowed by special permit	Multi-family housing allowed by right in most residential areas; cluster developments encouraged with density bonuses for LID features and no maximum lot coverage	multi-family allowed in Residential and General Business zones by right; not "Residential & Agricultural" district. (Zoning bylaw Section 4.1.1) OSRD allowed in Residential & Agricultural district. (Zoning Bylaw Section 4.1.1)	(Not applicable)	(Not applicable)	(Not applicable)
Setbacks	Required minimum front, side, and rear setbacks	Minimize, allow flexibility	Clear standards that minimize and in some instances eliminate setbacks	Required minimums. (Zoning bylaws Section 4.1.1)	(Not applicable)	(Not applicable)	(Not applicable)
Frontage	Required minimum frontage for each lot/unit	Minimize especially on curved streets and cul-de-sacs	No minimums in some instances, tied into other standards like OSRD design and shared driveways.	Required minimums (Zoning Bylaw Section 4.1.1) Reduced in OSRD by special permit. (Zoning Bylaw Section 8.3.4)	(Not applicable)	(Not applicable)	(Not applicable)
Common driveways	Often not allowed, or strict limitations	Allow for 2-3 residential units	Allow for up to 4 residential units, preferably constructed with permeable pavers or pavement	not allowed except in special use district. (Zoning Bylaw Sections 4.3.1; 9.1.5)	not addressed	not addressed	(Not applicable)



Factors	Conventional	Better	Best	Community's Zoning	Community's Subdivision Rules & Regulations	Community's Site Plan Review	Community's Stormwater/LID Bylaw/Regulations
<b>GOAL 3: SMART DESIGNS THAT REDUCE OVERALL IMPERVIOUSNESS</b>							
Impervious cover limits and infiltration rates	Not usually addressed in zoning and subdivision regs for rural/suburban residential	Require no net increase in site run-off from pre- to post-development	Impervious cover limits tailored to the community and district type (i.e. <10% total impervious cover in rural districts, but higher in urban and redevelopment districts); post-development infiltration should be equal to or greater than pre-development.  Following best practice may also help communities comply with MS4 permit requirements	not addressed.	not addressed	not addressed	(Not applicable)
Street location	Numeric and geometric standards based primarily on vehicular travel and safety, with basic pedestrian requirements e.g. sidewalks	Flexibility in applying standards, to reduce area of impact, grading, avoid key natural features	OSRD design preferred by-right. Require locating streets to minimize grading and road length, avoid important natural features	(Not applicable)	right angles generally required at intersections, etc. (Subdivision Regs Section 5.01)	(Not applicable)	(Not applicable)
Road width	Major and minor categories, 24-30'	Wide, medium, narrow categories. 22-24' max, plus 2' shoulders	Wide, medium, narrow, and alley categories. 20-24' widest for 2 travel lanes, 18-20' low traffic residential neighborhood, plus 2' shoulders. Allow alleys and other low traffic or secondary emergency access and all shoulders to use alternative, permeable materials.	(Not applicable)	min 24 ft. (Subdivision Regs Section 5.02 (B))	(Not applicable)	(Not applicable)
Road ROW width	50-75', fully cleared and graded	40-50', some flexibility in extent of clearing	20-50' depending on road type	not addressed.	Min 50 ft. (Subdivision Regs Section 5.02(A))	not addressed.	not addressed
Access Options	No common drives allowed, dead end allowed with limit on length and # of units	Allow dead end with limit on length and # of units. Allow common drives up to 2-3 units	Allow one way loop streets. Allow common drives up to 4 units, and alleys and rear-loading garages where suitable.	(Not applicable)	dead end allowed with max length. (Subdivision Regs 5.03(D))	(Not applicable)	(Not applicable)
Dead Ends/Cul-de-sacs	120 ft or more minimum turnaround	Minimize end radii – 35 ft	Allow hammerhead turnaround	(Not applicable)	min diameter 110ft. (Subdivision Regs Section 5.03(E))	(Not applicable)	(Not applicable)

Factors	Conventional	Better	Best	Community's Zoning	Community's Subdivision Rules & Regulations	Community's Site Plan Review	Community's Stormwater/LID Bylaw/Regulations
Cul-de-sacs	Full pavement standard	Encourage center landscaping with bioretention	Require center landscaping with bioretention	<i>(Not applicable)</i>	leave center in natural state or landscaping. (Subdivision Regs Section 5.03(E)(2))	<i>(Not applicable)</i>	<i>(Not applicable)</i>
Curbing	Curbing required full length both sides of road	Allow curb breaks or curb flush with pavement to enable water to flow to vegetated LID features	Open drainage with roadside swales and no curbs preferred	<i>(Not applicable)</i>	Required on both sides of road. (Subdivision Regs Section 5.04)	not addressed	not addressed
Roadside Swales	Allowed as an option	Preferred over closed drainage	Preferred, with criteria for proper design. Adoption of technical specifications and design templates for green infrastructure recommended	<i>(Not applicable)</i>	Encouraged. (Subdivision Regs Section 5.06(B))	not addressed	not addressed
Utilities	Off sets required contributing to wide road ROWs	Not specified, flexible	Allow under road, sidewalks or immediately adjacent to roads to enable placement of roadside swales.	<i>(Not applicable)</i>	not specified.	not addressed	<i>(Not applicable)</i>
Sidewalks	Concrete or bituminous	Some flexibility in material and design	Prefer permeable pavement or permeable pavers	<i>(Not applicable)</i>	Bituminous. (Subdivision Regs Section 6.03(D))	not addressed	<i>(Not applicable)</i>
Sidewalk location	Required both sides of road	Allow on only 1 side of road especially in low density neighborhoods	Prefer siting with land contours and for best pedestrian utility (e.g. connect with common areas and shared open spaces) – not necessarily immediately parallel to road.	<i>(Not applicable)</i>	Both sides of road. (Subdivision Regs Section 5.04(B))	not addressed	<i>(Not applicable)</i>
Sidewalk drainage	Drains to road closed drainage system	Not addressed	Disconnect drainage from road system – e.g. adjacent green strips or within vegetated areas that can absorb sheet flow	<i>(Not applicable)</i>	not addressed.	not separately addressed.	<i>(Not applicable)</i>

Factors	Conventional	Better	Best	Community's Zoning	Community's Subdivision Rules & Regulations	Community's Site Plan Review	Community's Stormwater/LID Bylaw/Regulations
<b>GOAL 4: ADOPT GREEN INFRASTRUCTURE STORMWATER MANAGEMENT PROVISIONS</b>							
Rooftop runoff	Prohibit directing clean roof runoff into closed municipal drainage systems.	Allow clean roof runoff to be directed to landscaped or naturally vegetated areas capable of absorbing without erosion, or infiltration	Require directing clean roof runoff to landscaped or naturally vegetated areas capable of absorbing, or infiltration	<i>(Not applicable)</i>	Rooftop runoff required to be infiltrated on site. (Subdivision Regs Section 5.06(4))	n/a	LID credit provided when rooftop drainage disconnected. (Stormwater management regs, App. A)
Overall stormwater design; piping and surficial retention vs. LID	Conventional stormwater system design standards	Encourage LID features and BMPs; design standards often not specified	LID design standard encouraging infiltration, allowing surficial ponding of retained runoff for up to 72 hours; systems designed for larger volume storms, accounting for future precipitation predictions; credit for green roofs towards stormwater requirements. Following best practice may also help communities comply with MS4 permit requirements	<i>(Not applicable)</i>	LID encouraged, but design standards not specified. (Subdivision Regs Section 5.06(B)(2))	LID Encouraged. (Zoning Bylaw Section 6.5.11)	Use of LID required to maximum extent feasible for New Development. (Stormwater Management Regs, Section 10(A)(1)) and Redevelopment (Stormwater Management Regs Section 10(B)(5))  LID features encouraged (Stormwater Management Regs, App. A)
Site Plan/Design Requirements	LID not addressed	Encourage use of LID features in site design - such as reduced imperviousness, maintaining natural hydrology, preserving open space, and rainwater reuse	Include bioretention and other vegetated LID features in site landscaping/open space requirements. Following best practice may also help communities comply with MS4 permit requirements. See section 2.3.5 of the MS4 permit for more information	<i>(Not applicable)</i>	n/a	n/a	LID credits available to encourage use. (Stormwater Management Regulation App. A)
Allow easy siting of LID features (bioretention, swales, etc.)	Often not addressed, may require waivers from subdivision standards	Encouraged along road ROW	Allowed on lots, common open space, or road ROW, easement recorded. For commercial development, allow an increase in floor area ratio or other developmental incentives for green roofs	Depends on zone. Few restrictions, doesn't look like waivers are required.	Encouraged. (Subdivision Regs Section 5.06(B)(2))	n/a	<i>(Not applicable)</i>

Factors	Conventional	Better	Best	Community's Zoning	Community's Subdivision Rules & Regulations	Community's Site Plan Review	Community's Stormwater/LID Bylaw/Regulations
Permeable paving	Often not addressed, may require waivers from subdivision standards	Allowed on private residential lots for parking, patios, etc.	Allowed for residential drives, parking stalls, spillover parking spaces, emergency access ways (with proper engineering support for emergency vehicles) Two track design allowed for driveways and secondary emergency access ways (where required)	(Not applicable)	not addressed	not addressed	Would qualify for LID credit (therefore allowed). (Stormwater Management Regs App. A)
Stormwater management O&M plan	Typically only addressed if municipality has a stormwater or LID bylaw, or for areas subject to wetlands permitting	Required	Required, contents specified in alignment with current MassDEP Stormwater Handbook. Following best practice may also help communities comply with MS4 permit requirements	(Not applicable)	n/a	n/a	Required and contents specified in alignment with MA and EPA standards. (Stormwater Management Regs, Section 9)
Construction Erosion and Sedimentation Plan, and stormwater control	Basic general requirements	Required, contents specified - the site design process should include soil erosion and sedimentation control measures	Goes beyond minimum NPDES requirements. Requires minimization of site disturbance, reduction of construction waste, control measures not removed until proof of soil stabilization or reestablishment of vegetation. Written procedures for site inspection and enforcement included. Following best practice may also help communities comply with MS4 permit requirements. See section 2.3.5 of the MS4 permit for more information	(Not applicable)	Required. (Subdivision Regs Section 5.10)	Required. (Zoning Bylaw Section 10.6.8)	Required and contents specified. (Stormwater Management Regs Sections 8, 10(C))
Stormwater discharge detection & elimination	Not addressed	Discharges and connections noted and/or limits set on quantity and quality	Illicit discharges and connections are prohibited and enforced. Following best practice may also help communities comply with MS4 permit requirements. Find more information in section 2.3.4.a of the MS4 permit	(Not applicable)	(Not applicable)	(Not applicable)	Yes. (Stormwater Management Bylaw Section 232-202)

Factors	Conventional	Better	Best	Community's Zoning	Community's Subdivision Rules & Regulations	Community's Site Plan Review	Community's Stormwater/LID Bylaw/Regulations
Post- construction stormwater management and drainage patterns	Not addressed	Allow LID	Resemble pre-existing conditions of volume, velocity, quality and location, as nearly as possible, requiring LID to the max extent feasible.  Retain vol of runoff > 1in. per sq.ft. of impervious surface and/or remove 90% TSS post-construction & 50% TP generated on the site for new development, or >0.8in. per sq.ft and/or remove 80% TSS and 50% of TP load for redevelopment.  Following best practice may also help communities comply with MS4 permit requirements.	(Not applicable)	n/a	Resemble pre-existing conditions. (Zoning Bylaw Section 6.5.11)	Yes, updated for MS4 compliance. (Stormwater Management Regs Sections 10(A)&(B))
As-built surveys	Not addressed	Recommended	Required, with written instructions for process; electronic submittal allowed	(Not applicable)			
Intra-departmental communication and coordination	Not addressed	Informally or loosely occurring	Required for plan review and/or permit approvals				
Enforcement	No	Yes	Yes with fines. Same entity should oversee permit approvals and enforcement				

Factors	Conventional	Better	Best	Community's Zoning	Community's Subdivision Rules & Regulations	Community's Site Plan Review	Community's Stormwater/LID Bylaw/Regulations
<b>GOAL 5: ENCOURAGE EFFICIENT PARKING</b>							
Parking	Specific minimums set based on projected maximum use times	Encourage minimum # needed to serve routine use (e.g. 2/residential unit with any additional/visitors parking behind in driveway or on street).	Establish Maximum Parking spaces allowed. Do not require more than 2/residence. Allow tenants separate, optional lease agreements for parking.	Specific mins (Zoning Bylaw Sections 275-6.1.4-6.1.5); reductions may be allowed on case by case basis (Zoning Bylaw Section 275-6.1.6).	(Not applicable)	not separately addressed.	(Not applicable)
Commercial Parking	Specific minimums set based on projected maximum use times adding all on-site uses together.	Some flexibility to reduce minimums based on street or other available nearby parking or transit.	Allowed shared parking for uses with different peak demand times. Provide model agreements/deed restrictions. Reduce parking requirements near transit. Limit parking stall size (9ftx18ft max), with up to 30% smaller for compact cars	Specific mins (Zoning Bylaw Sections 275-6.1.4-6.1.5); reductions may be allowed on case by case basis (Zoning Bylaw Section 275-6.1.6).	(Not applicable)	no minimums addressed.	(Not applicable)
LID in Parking Areas	Often not addressed, may require waivers e.g. for planting islands to drain down rather than built up surrounded by curbs	Allow LID/bioretenion within parking areas.	Require landscaping within parking areas, as LID/bioretenion, at a minimum of 10% of the interior area landscaped and a minimum of 25 square feet for island planting areas.	LID encouraged to accomplish required drainage. (Zoning Bylaw Section 275-6.5.11(1))	not addressed	Separate landscape plan required for parking areas of 100 spaces or more. (Zoning Bylaw Section 275-10.5.6(8))	Credit provided for green infrastructure to recharge stormwater. (Stormwater Regulations, Credit No. 5)

## Common Acronyms

BoA	Board of Appeals
BoH	Board of Health
BMP	Best Management Practice
CC	Conservation Commission
CR	Conservation Restriction pursuant to MGL 184, S.31-33
DPW	Department of Public Works
GI	Green Infrastructure
HA	Homeowner's Association
LID	Low Impact Development
MS4	Municipal Separate Storm Sewer System
NRPD	Natural Resource Protection Development
NRPZ	Natural Resource Protection Zoning
OS	Open Space
OSRD	Open Space Residential Design
PB	Planning Board
ROW	Right of Way
RS	Residential Single
RG	Residential General
SPR	Site Plan Review
SP	Special Permit
SPGA	Special Permit Granting Authority

## Resources and Model Bylaws/Regulations

For additional information on best practices, model LID and OSRD bylaws and regulations, case studies, and other related resources see:

### [www.massaudubon.org/LIDCost](http://www.massaudubon.org/LIDCost)

- Five free fact sheets on Cost-Effective LID
- Presentations and other resources

### Additional resources

- Massachusetts Smart Growth/Smart Energy Toolkit, including case studies and model bylaws: [www.mass.gov/envir/smart\\_growth\\_toolkit/](http://www.mass.gov/envir/smart_growth_toolkit/)
- Massachusetts Smart Growth Model Open Space Design/Natural Resource Protection Zoning: [www.mass.gov/files/documents/2017/11/03/Open Space Design \(OSD\)-Natural Resource Protection Zoning \(NRPZ\)\\_0.pdf](http://www.mass.gov/files/documents/2017/11/03/Open_Space_Design_(OSD)-Natural_Resource_Protection_Zoning_(NRPZ)_0.pdf)
- Metropolitan Area Planning Council's (MAPC) LID Toolkit [www.mapc.org/resource-library/low-impact-development-toolkit/](http://www.mapc.org/resource-library/low-impact-development-toolkit/)

MAPC's Environmental Planning Services:

<https://www.mapc.org/our-work/expertise/environment/>

- MA-APA *Neighborhood Road Design Guidebook* [https://www.apa-ma.org/wp-content/uploads/2018/12/NRB\\_Guidebook\\_2011.pdf](https://www.apa-ma.org/wp-content/uploads/2018/12/NRB_Guidebook_2011.pdf)
- EPA's Water Quality Scorecard, which was reviewed and incorporated into this analysis framework in July 2017, including using the 5 goals listed: [www.epa.gov/smartgrowth/water-quality-scorecard](http://www.epa.gov/smartgrowth/water-quality-scorecard)
- MassDEP's Stormwater Program and MS4 compliance resources: [www.mass.gov/guides/municipal-compliance-fact-sheet-stormwater](http://www.mass.gov/guides/municipal-compliance-fact-sheet-stormwater)





## Contact Us

For questions regarding this analysis or how to implement LID in your community, please feel free to contact us:

Mass Audubon  
[advocacy@massaudubon.org](mailto:advocacy@massaudubon.org)  
[www.massaudubon.org/lidcost](http://www.massaudubon.org/lidcost)



## **Appendix K**

# **Inventory of Municipal BMP Retrofit Opportunities**

## Inventory of Municipal BMP Retrofit Opportunities

- 1. Edwards Road Boat Ramp (Jellyfish Filters)**
  - a. Contech Fabrication Drawing
- 2. Foxborough Regional Charter School**
  - a. PARE Corp Design Plan
- 3. East Street and Cocasset Street Intersection Redesign**
  - a. PARE Corp/Fuss & O'Neill Design
- 4. 90 North Carl Annon Court**
  - a. Neponset Stormwater Partnership Grant
- 5. Payson Road Athletic Complex – North Parking Lot**
  - a. Town-Wide Green Infrastructure Master Plan (Fuss & O'Neill)
- 6. Payson Road Athletic Complex – South Parking Lot**
  - a. Town-Wide Green Infrastructure Master Plan (Fuss & O'Neill)
- 7. Payson Road Athletic Complex – Ernie George Field**
  - a. Town-Wide Green Infrastructure Master Plan (Fuss & O'Neill)
- 8. Kersey Point Conservation Area**
  - a. Town-Wide Green Infrastructure Master Plan (Fuss & O'Neill)
- 9. Sunset Estates**
  - a. Town-Wide Green Infrastructure Master Plan (Fuss & O'Neill)
- 10. Igo Elementary School**
  - a. Town-Wide Green Infrastructure Master Plan (Fuss & O'Neill)
- 11. Council on Aging**
  - a. Town-Wide Green Infrastructure Master Plan (Fuss & O'Neill)
- 12. Lane Homestead Conservation Area**
  - a. Town-Wide Green Infrastructure Master Plan (Fuss & O'Neill)
- 13. Cocasset Street Underpass Drainage**
  - a. Town-Wide Green Infrastructure Master Plan (Fuss & O'Neill)

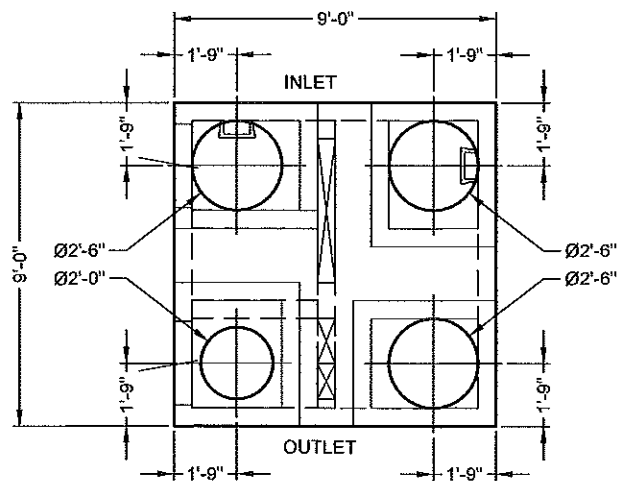

**PLAN VIEW**

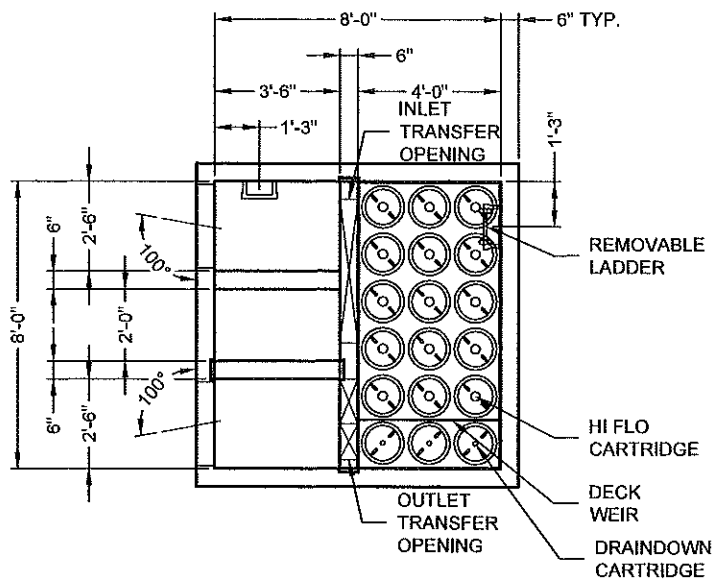

**PLAN VIEW**  
(TOP SLAB NOT SHOWN FOR CLARITY)

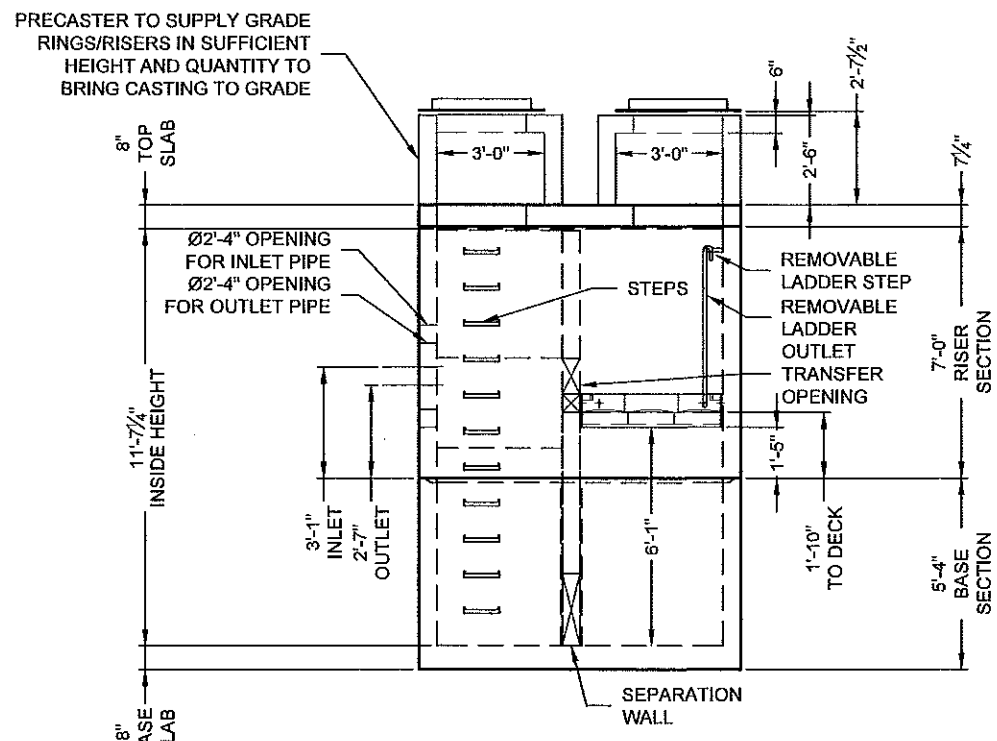

**ELEVATION VIEW**

**MATERIAL LIST - PROVIDED BY CONTECH**

COUNT	DESCRIPTION	PROVIDED BY	INSTALLED BY
15	54" HI-FLO CARTRIDGE (70 mm ORIFICE)	CONTECH	PRECASTER
3	54" DRAINDOWN CARTRIDGE (35 mm ORIFICE)	CONTECH	PRECASTER
0	CARTRIDGE BLANK (NO ORIFICE)	CONTECH	PRECASTER
1	JELLYFISH VAULT 18-CARTRIDGE DECK, STANDARD	CONTECH	PRECASTER
1	JOINT SEALANT (BY PRECASTER)	PRECASTER	CONTRACTOR
3	Ø30" X 4" FRAME & COVER, EJ #41600484	CONTECH	CONTRACTOR
1	Ø24" X 4" FRAME & COVER, EJ #41600389	CONTECH	CONTRACTOR
4 PLCS.	30" X 36" RISER WITH TOP SLAB	CONTECH	CONTRACTOR
13	STEPS, P10CTS LANE LADDER, OR EQUIVALENT	PRECASTER	PRECASTER
1	STEP, LANE P-14850 (FOR LADDER ATTACHMENT)	PRECASTER	PRECASTER
1	REMOVABLE, LANE 4-STEP POLY LADDER	PRECASTER	PRECASTER

**GENERAL NOTES**

- DESIGN LOADING - AASHTO HS-20
- DESIGN SPECIFICATION - ACI 318
- JOINT SEALANT SHALL CONFORM TO ASTM C-990 OR ASTM C-443
- CONCRETE MINIMUM STRENGTH - 5,000 PSI AT 28 DAYS
- EARTH COVER VARIES FROM 0'-0" MIN. TO 3'-0" MAX.
- GROUND WATER ELEVATION ASSUMED AT OUTLET PIPE INVERT
- MANUFACTURING TOLERANCE = +/- 1/2-INCH
- SOME HIDDEN LINES MAY BE OMITTED FOR CLARITY.

**INSTALLATION NOTES**

- PRECASTER TO SHIP FRAMES AND COVERS WITH STRUCTURE.
- REFER TO CONTECH ASSEMBLY INSTRUCTIONS FOR ADDITIONAL INFORMATION.
- PRECASTER TO SUPPLY BUTYL MASTIC JOINT SEALANT.
- PIPE OPENINGS SHALL BE STENCILED "INLET" OR "OUTLET" AS APPROPRIATE.
- APPLYING ALIGNMENT MARKS ON ALL PIECES OF MULTIPLE PIECE ASSEMBLIES IS ENCOURAGED.
- IF STRUCTURE IS DELIVERED IN MULTIPLE SECTIONS, EACH PIECE SHALL BE LABELED WITH THE CONTECH PROJECT NUMBER, SEQUENCE NUMBER AND SITE DESIGNATION.
- ACCESS STEPS SHALL BE INSTALLED IN ACCORDANCE WITH ASTM-478 AND AASHTO M-199. IN LOCATIONS WHERE INTERNALS WOULD INTERFERE WITH INSTALLTION, PRECASTER IS TO PREDRILL MOUNTING HOLES.

**STRUCTURE WEIGHTS**  
 APPROXIMATE HEAVIEST PICK OF 3 PIECES = 25,000 LBS  
 TOP SLAB = 6,500 LBS  
 RISER SECTION = 25,500 LBS  
 BASE SECTION = 24,000 LBS

**SITE SPECIFIC PROJECT INFORMATION**  
 RIM ELEVATION = 276.80'  
 TOP OF STRUCTURE ELEVATION = 273.85'  
 INLET PIPE INVERT ELEVATION = 268.58'  
 INLET DIAMETER AND MATERIAL = 18" RCP  
 OUTLET PIPE INVERT ELEVATION = 268.08'  
 OUTLET DIAMETER AND MATERIAL = 18" RCP  
 OUTSIDE BOTTOM OF STRUCTURE ELEVATION = 260.91'

CONTECH  
**FABRICATION**  
 DRAWING

ARRO  
 LAYOUT 7  
 CLASS 600

The design and information shown on this drawing is provided as a service to the project owner, engineer and contractor by CONTECH Engineered Solutions LLC or its authorized representative. It is not to be used for any other project without the written consent of CONTECH. Failure to comply with the terms of this agreement may result in legal action at the discretion of CONTECH. CONTECH does not warrant any liability or responsibility for such use.

If discrepancies between the supplied information upon which this design was based and the actual conditions are encountered at the work site, the contractor is to immediately report the same to CONTECH. CONTECH is not responsible for any delays or costs incurred as a result of such discrepancies.

MARK	DATE	REVISION DESCRIPTION	BY

8' X 8' JELLYFISH - 565122-010  
 EDWARDS ROAD - FOXBOROUGH  
 FOXBOROUGH, MA  
 SITE DESIGNATION: JELLYFISH

**CONTECH**  
 ENGINEERED SOLUTIONS LLC  
 WWW.CONTECHES.COM  
 802 Centre Pointe Dr., Suite 400, West Chester, OH 45389  
 800-338-1122 513-545-7700 513-645-7933 FAX

**Jellyfish Filter**  
 THIS PRODUCT MAY BE PROTECTED BY ONE OR MORE OF THE FOLLOWING INTERNATIONAL PATENT REGISTRATIONS:

DATE: 06/11/2020  
 DESIGNED: DRA DRAWN: RRB  
 CHECKED: KMC APPROVED: DRA  
 PROJECT No.: 565122 SEQUENCE No.: 010  
 SHEET: 1 OF 6

I:\AD\CONTECH\CPI\COM\ROOT\MERLIN\PROJECT\ACTIVE\565122-010\JELLYFISH\DRAWINGS\565122-010-FFD0809-CONFAB.DWG 6/18/2020 9:50 AM



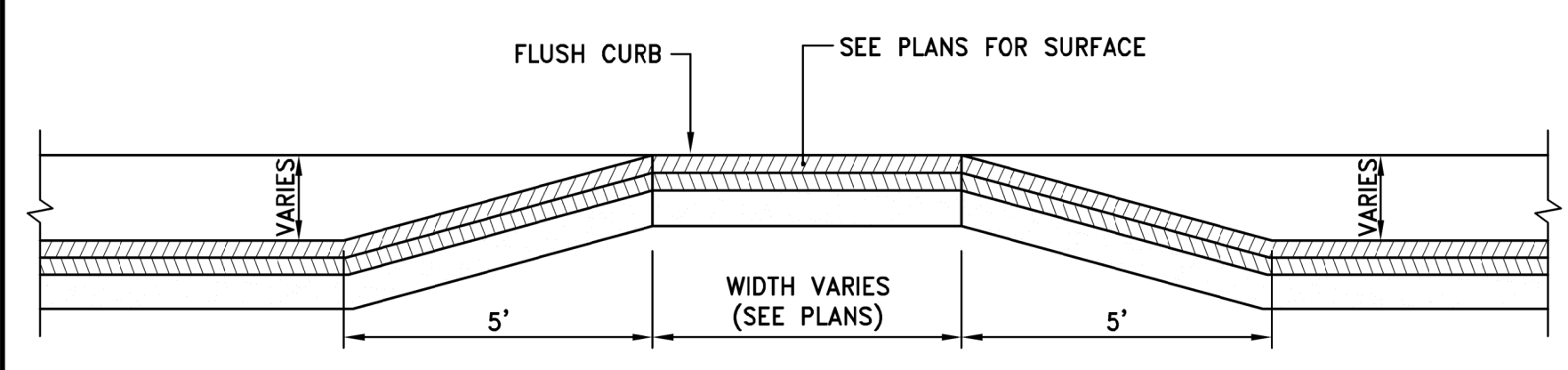

NOTE:  
 SPEED BUMP TO BE PAINTED WITH WHITE EPOXY RESIN PAVEMENT MARKING.

**SPEED TABLE SECTION DETAIL**  
 NOT TO SCALE

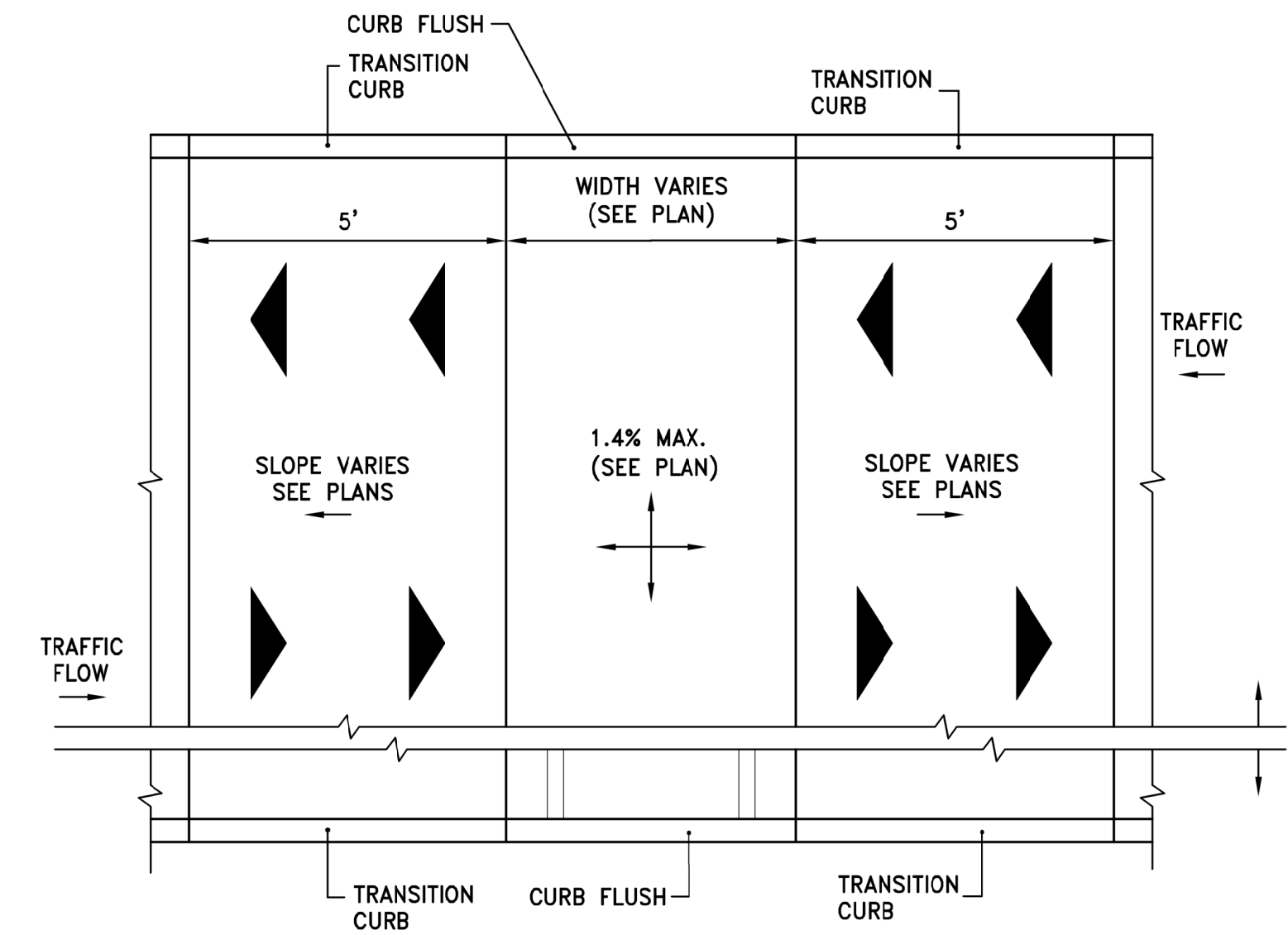

**SPEED TABLE PLAN DETAIL**  
 NOT TO SCALE

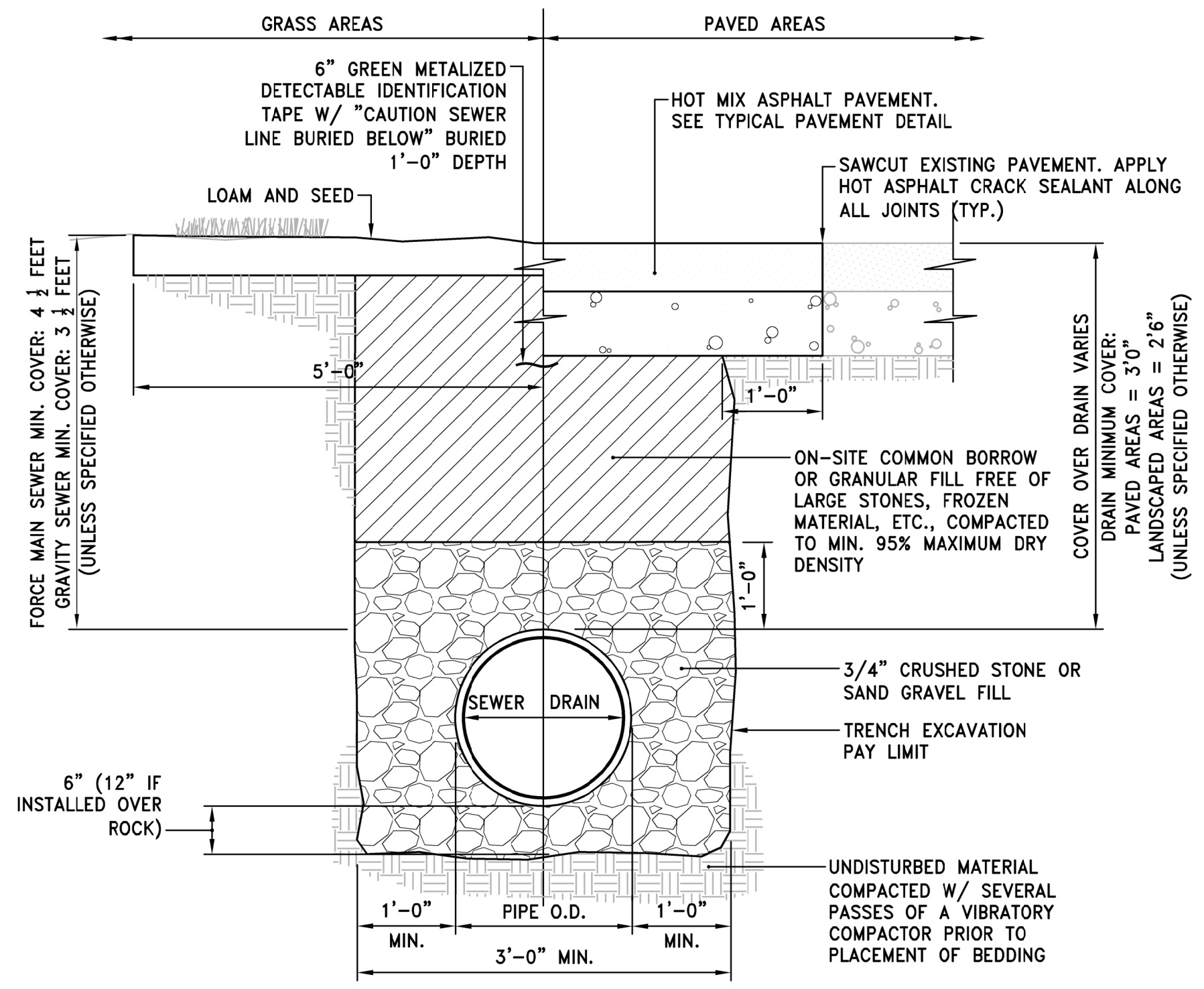

- NOTES:
- WHERE THE DISTANCE BETWEEN THE SAWCUT AND EDGE OF PAVEMENT IS 3' OR LESS, THE CONTRACTOR SHALL REPLACE THE PAVEMENT FROM THE TRENCH EDGE TO THE EXISTING EDGE OF PAVEMENT.
  - 3/4" DIA. CRUSHED STONE SHALL BE USED AS BEDDING WHERE TRENCH IS BELOW THE GROUND WATER TABLE.

**SEWER/DRAIN TRENCH DETAIL**  
 NOT TO SCALE

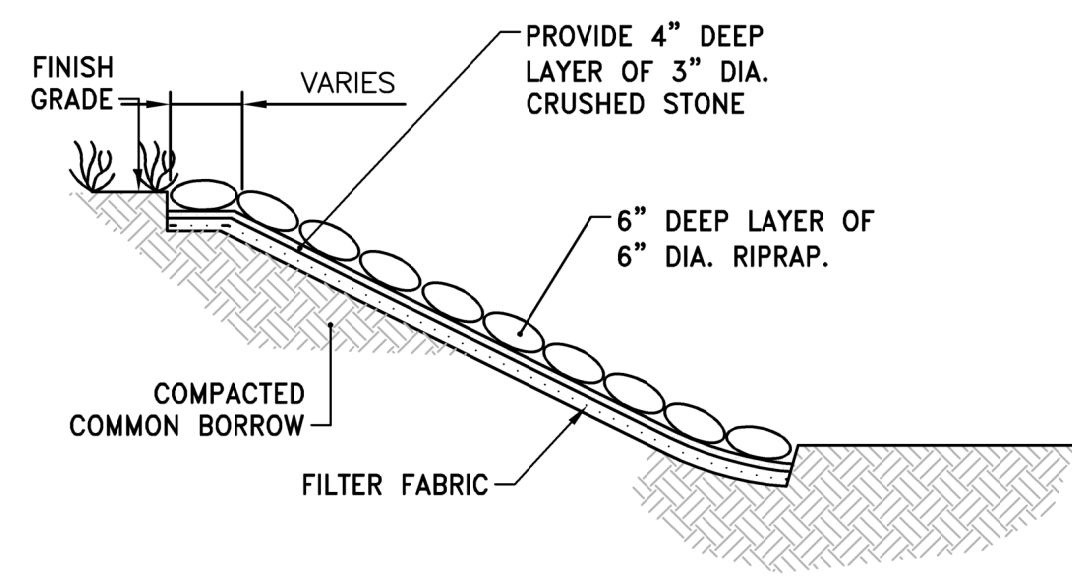

**RRS RIPRAP SLOPE**  
 NOT TO SCALE

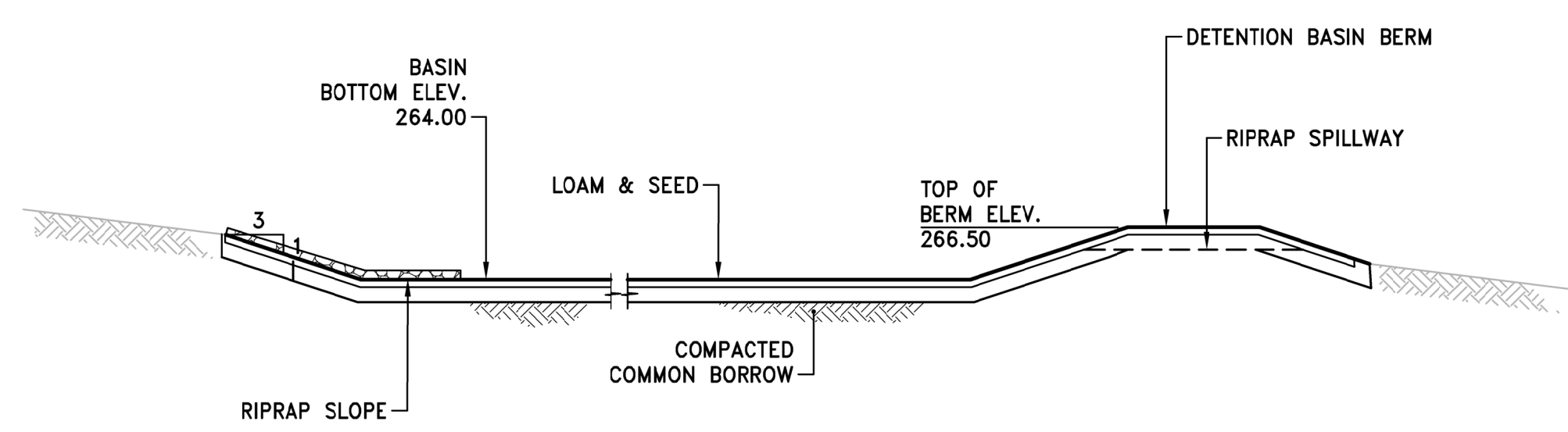

- NOTES:
- DETENTION BASIN BERM SHALL BE CONSTRUCTED WITH COMMON BORROW PLACED IN 12" LIFTS AND COMPACTED TO 95% TO FINISH GRADE.
  - REMOVE ALL EXISTING TOPSOIL AND ORGANIC MATERIAL PRIOR TO CONSTRUCTING DETENTION BASIN BERM.
  - COMMON BORROW SHALL EXTEND A MINIMUM OF 12" BELOW DETENTION BASIN BOTTOM.

**DETENTION BASIN SECTION**  
 NOT TO SCALE

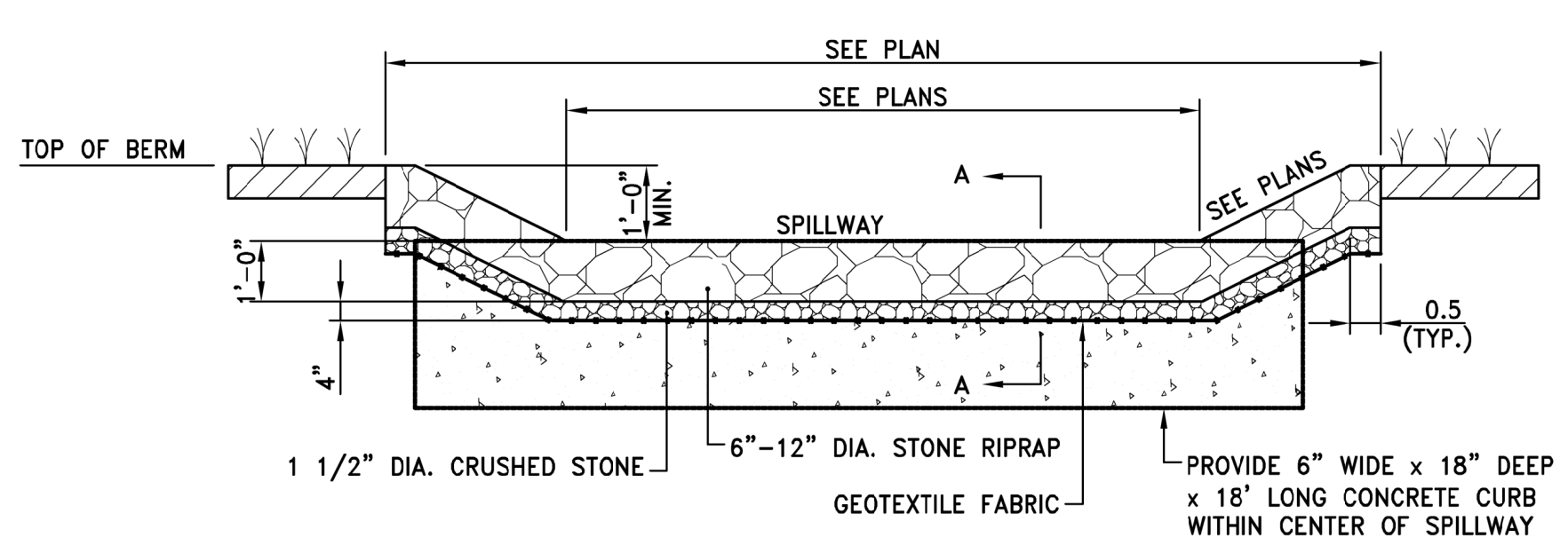

**RRS RIPRAP SPILLWAY DETAIL**  
 NOT TO SCALE

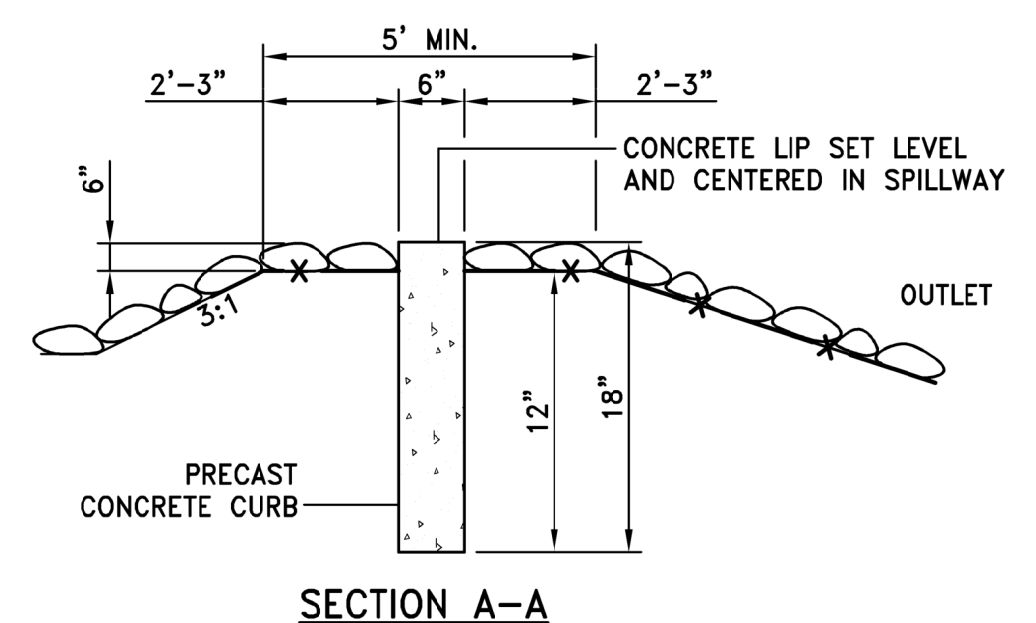

NOTE:  
 CONTRACTOR SHALL FILL VOIDS BETWEEN CURB SECTIONS WITH MORTAR

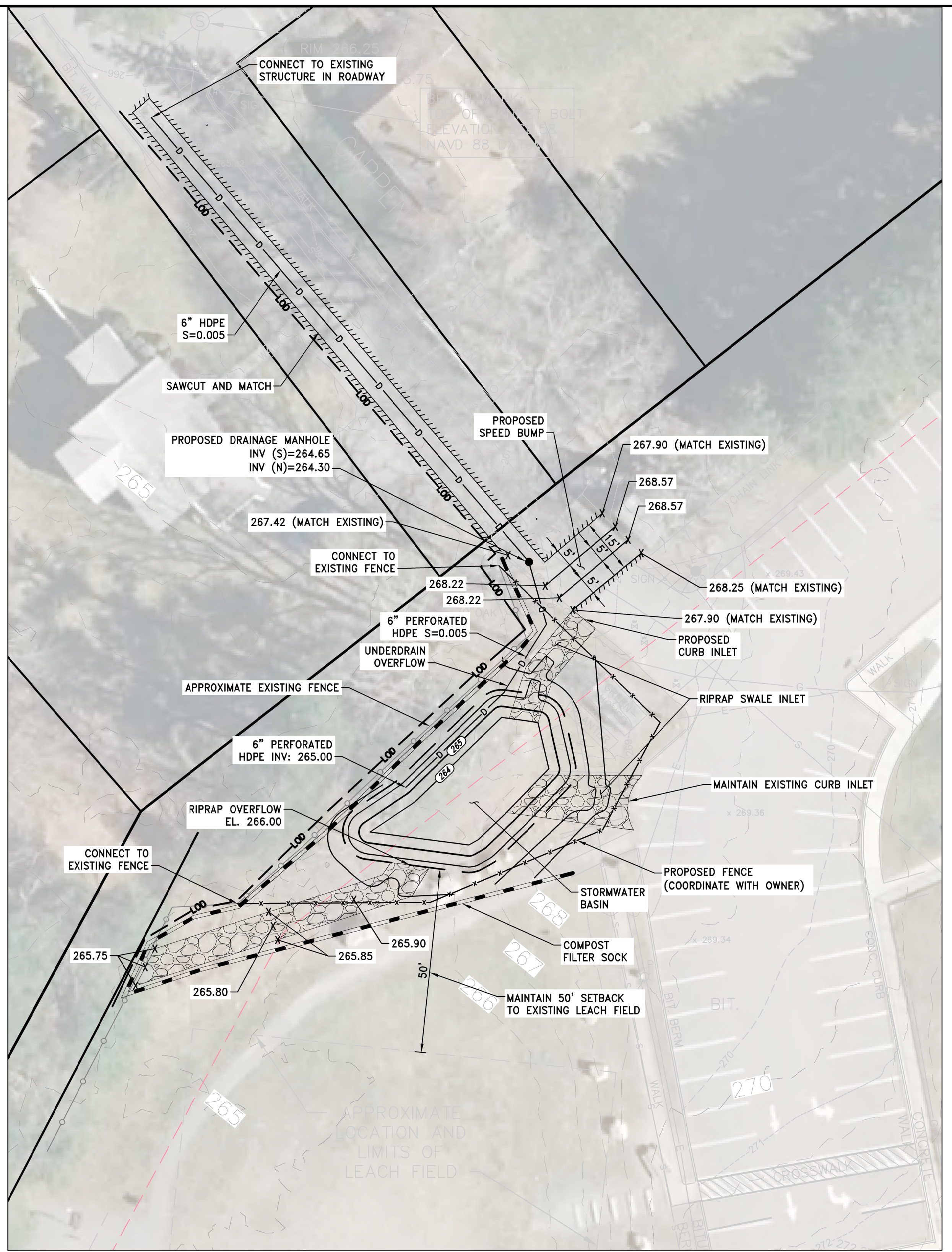

Scale: 1"=20'  
 0 10' 20' 40'



File: J:\DWG\2020\04\00F11\STP01.dwg Layout: CS-102 Plotted: 2022-06-20 5:21 PM Saved: 2022-06-20 5:18 PM User: Choyden

MS VIEW: LAYER STATE: PC3: NONE STB/CTB: FO.STB

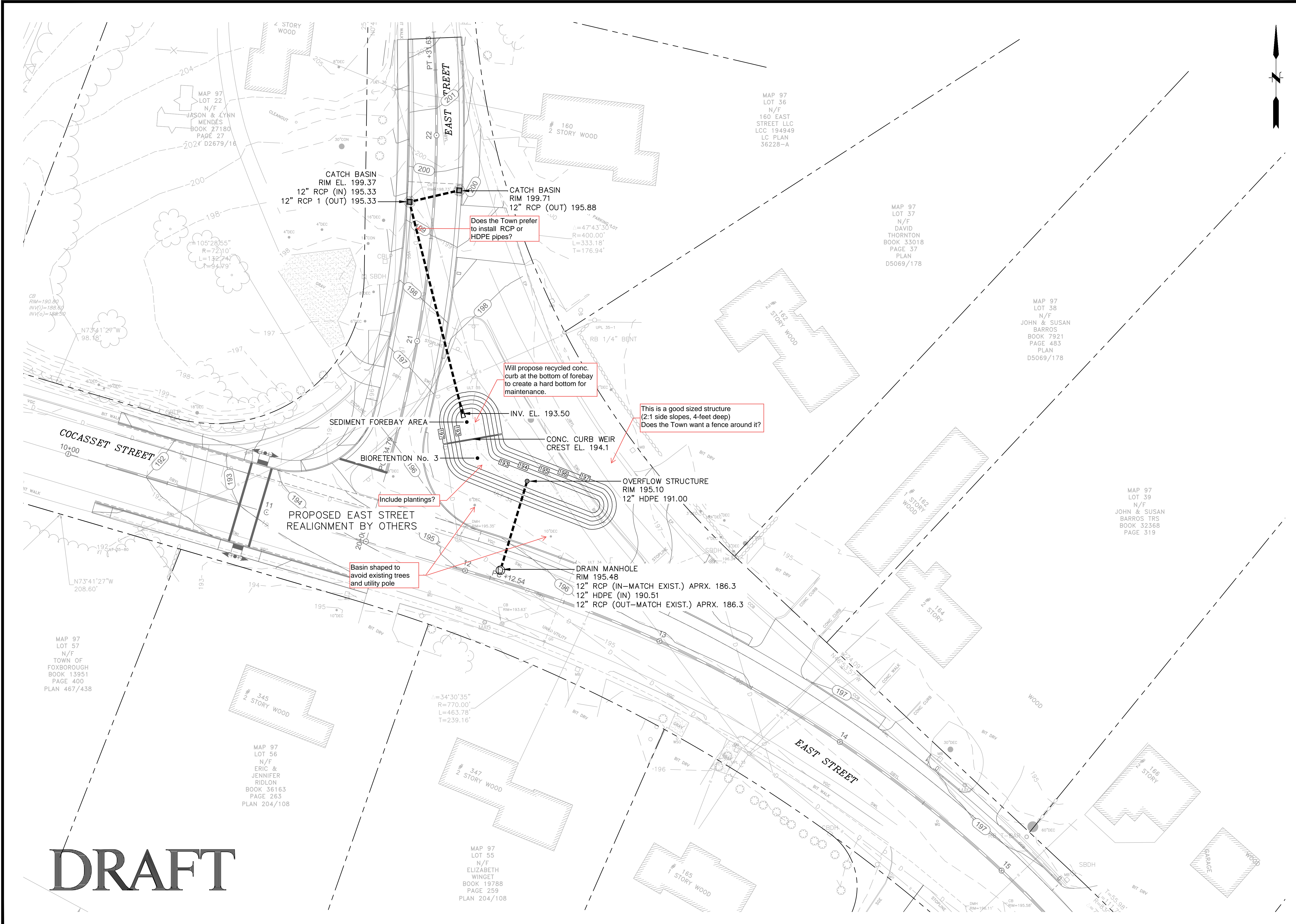

# DRAFT

NO.	DATE	DESCRIPTION	DESIGNER	REVIEWER

SCALE: HORIZ.: 1"= 20'  
 VERT.: 1"= 20'  
 DATUM: NAD83  
 HORIZ.: NAVD83  
 VERT.: NAVD83  
 GRAPHIC SCALE

**FUSS & O'NEILL**  
 517 IRON HORSE WAY, SUITE 204  
 401 B&L BLDG  
 www.fussandoneill.com

TOWN OF FOXBOROUGH  
 LAYOUT PLAN NO. 2  
 GREEN INFRASTRUCTURE  
 COCASSET STREET RAIL UNDERPASS DESIGN  
 FOXBOROUGH MASSACHUSETTS

PROJ. No.: 2020040.F11  
 DATE: JUNE 2022

**CS-102**

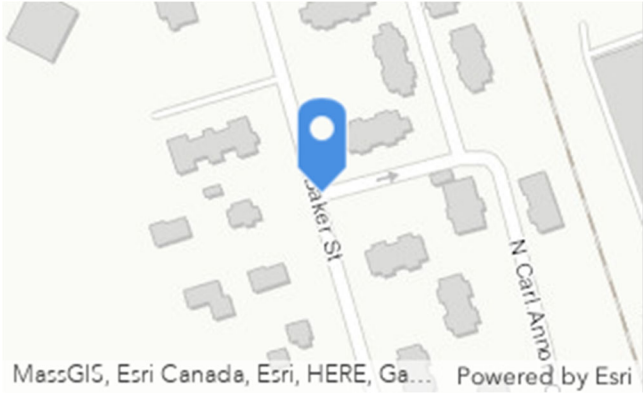

ID#: CSEP-021a	
<p><b>Name:</b> Baxter Street ROW</p>	<p><b>Site Location:</b></p>
<p><b>Site Description:</b> Runoff on Baxter street comes over cape cod berm. Evidence of puddling. Very few catch basins on road. Sanitary pipe and water line conflicts. 5' wide sidewalk, 3-4' grass area. Safety is a concern with pedestrians and cars. Baxter Street is a busy road.</p>	
<p><b>BMP Description:</b> Propose a grass swale along road between the existing 5' sidewalk and curb. Drainage to enter swale through curb cuts. Swale would be shallow with limited soil modifications to avoid conflicts with utilities.</p>	
GENERAL SITE INFORMATION	RETROFIT DETAILS
<p><b>Ownership:</b> Public</p>	<p><b>Project Candidate Score:</b> 4 - Good Site</p>
<p><b>Primary Land Use:</b> Road/ROW</p>	<p><b>Proposed BMP/Pretreatment:</b> Dry Swale/Forebay</p>
<p><b>Existing BMP on site?</b> No</p>	<p><b>Primary Non-Structural Controls:</b> Street/Parking Lot Sweeping</p>
<p><b>Is site a hotspot or LUHPPL?</b> No</p>	<p><b>Primary BMP Benefit(s):</b> Water Quality</p>
<p><b>Primary Pollutant:</b> Sediment</p>	<p><b>Primary Site Conflict(s):</b> Utilities</p>
<p><b>Soils:</b> Good Infiltration</p>	<p><b>Maintenance Concern(s):</b> Debris from Baxter Street. Town would like to have the grassed area be mowed only.</p>
RETROFIT SIZING INFORMATION	
<p><b>Estimated Drainage Area (ac):</b> TBD</p>	<p><b>Estimated Practice Area (ac):</b> TBD</p>
<p><b>Estimated Impervious Area (ac):</b> TBD</p>	<p><b>Existing Head Available?</b></p>

**Date Assessed:** November 16, 2020 11:26

**Assessed by:** Gk



**PHOTOS/SKETCHES**



**Photo Caption:** Swale location (east ROW, looking south)



**Photo Caption:** Entrance to Housing Authority



**Photo Caption:** ROW

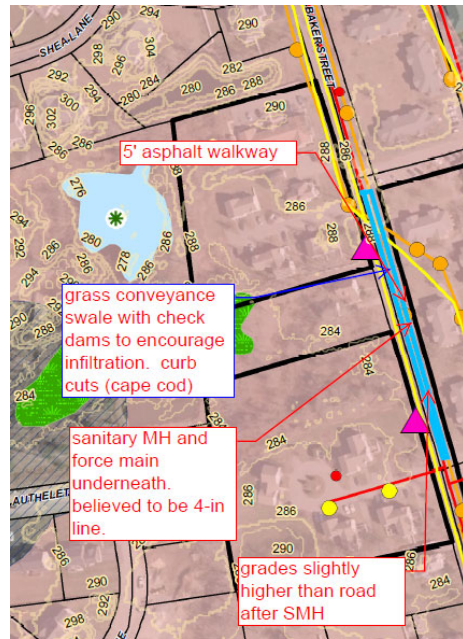

**Site Sketch**

**Date Assessed:** November 16, 2020 11:26

**Assessed by:** Gk



# Town-Wide Green Infrastructure Master Plan Town of Foxborough, MA

JUNE 2022

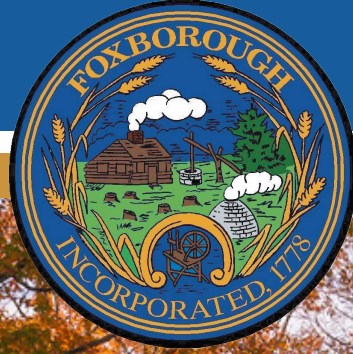

Financial assistance was provided by the Executive Office of Energy & Environmental Affairs (EEA) under the FY22 Municipal Vulnerability Preparedness (MVP) Grant Program. The MVP Action Grant offers financial resources to municipalities that are seeking to advance priority climate adaptation actions to address climate change impacts resulting from extreme weather, sea level rise, inland and coastal flooding, severe heat, and other climate impacts.

**Fuss & O'Neill Team**

William Guenther, MS

Allen Tevyaw, MS

Celicia Boyden, EIT, MS

Erik Mas, PE

Shawn Martin, PE

Stefan Bengtson, MS, MESM

Alex Duryea, MESM

**Town of Foxborough Project Team**

Christopher F. Gallagher, PE - Public Works Director

Lance Priore - Town Engineer

William Keegan - Town Manager

Michael Johns - Assistant Town Manager



# Table of Contents

<b>Executive Summary</b> .....	1
<b>1. Introduction</b> .....	2
<b>2. Current Conditions</b> .....	4
2.1 Undersized and Aging SW Infrastructure .....	4
2.2 Improving Stormwater Protects Valuable Resources .....	5
<b>3. Climate Change Impacts to Foxborough</b> .....	6
3.1 What Climate Change Means for Stormwater.....	7
3.2 Water Quality and Climate Change .....	7
<b>4. Prioritized Green Infrastructure Concepts</b> .....	9
4.1 Site Selection and Assessment Process .....	9
4.1.1 Payson Road Athletic Complex – North Parking Lot.....	11
4.1.2 Payson Road Athletic Complex – South Parking Lot .....	13
4.1.3 Payson Road Athletic Complex – Ernie George Field .....	15
4.1.4 Kersey Point Conservation Area.....	17
4.1.5 Sunset Estates.....	19
4.1.6 Igo Elementary School .....	23
4.1.7 Council on Aging.....	25
4.1.8 Lane Homestead Conservation Area.....	27
4.2 Cocasset Street GI Conceptual Designs & Cost Estimates .....	29
4.3 Other GI Ideas .....	33
4.4 Typical Details.....	34
<b>5. Funding Sources</b> .....	40
5.1 State Funding Sources .....	40
5.2 Federal Funding Sources .....	42

# Executive Summary

The purpose of this Town-Wide Green Infrastructure Master Plan is to identify opportunities to address stormwater-driven flooding hazards and improve water quality through nature-based, green infrastructure practices within the Town of Foxborough.

As precipitation events continue to become more intense and less predictable with climate change, undersized and aging stormwater infrastructure in Foxborough is expected to pose a greater threat of failure and flooding, such as already exists at the Cocasset Street underpass. Foxborough also sits on top of two EPA-designated Sole Source Aquifers, which means that the aquifer provides at least 50% of the drinking water for its service area, and that there are no other reasonably available alternative drinking water sources to fall back on.

Green infrastructure, also referred to as “green stormwater infrastructure” (GSI) and “low impact development” (LID), is an alternative approach to traditional stormwater management. It can be constructed in stages, as funding and resources become available and as roads or Town buildings undergo repaving, renovation, or other upgrades. Unlike traditional underground drainage that needs to be constructed in whole to provide any benefit, GSI solutions can provide incremental benefits as they are implemented, allowing them to be phased in over time.

GSI practices like those identified in this plan help protect our drinking water quality by promoting stormwater infiltration to replenish the aquifer and by treating stormwater pollutants before they make their way into groundwater.

In developing this Plan, Town-owned sites throughout Foxborough were screened for GSI opportunities and other nature-based solutions to increase flood resiliency and improve or protect water quality. Federal, State, and Local data sets were overlaid to identify locations where GSI may be most suitable. The list of potential sites was also examined relative to ongoing planning and capital projects in the Town to identify project sites where GSI could

be incorporated in a cost-effective manner as part of a larger project (e.g., planned future redevelopment projects or repaving).

This plan identified nine sites with the best opportunities for near- and medium-term redevelopment projects.

- Payson Road Recreation Area – North Parking Lot
- Payson Road Recreation Area – South Parking Lot
- Payson Road Recreation Area – Ernie George Field
- Kersey Point Conservation Area
- Sunset Estates – Twilight Drive
- Sunset Estates – Sunrise Road
- Council on Aging
- Igo Elementary School
- Lane Homestead

Conceptual stormwater management designs were developed for these sites locations as part of the plan to support future implementation projects, along with standard engineering details.

Finally, the plan ends by identifying a range of federal, state, and local funding sources that can help the Town in implementing these projects and making Foxborough a more resilient community in the face of a changing climate.

# 1 Introduction

The Town of Foxborough has developed this Town-Wide Green Infrastructure Master Plan using funding through the Executive Office of Energy and Environmental Affairs Municipal Vulnerability Preparedness (MVP) Action Grant program. The purpose of the plan is to identify opportunities to address stormwater-driven flooding hazards and improve water quality through nature-based, green infrastructure practices. This nature-based approach looks at “end of the pipe” problems such as nutrient-impaired waters, aquifer protection, and known problem areas at stormwater outfalls and seeks to create long-term solutions by providing improved stormwater management in the corresponding upgradient drainage areas. The proposed green infrastructure improvements encompass a range of parcel-specific practices, linear green infrastructure in the municipal right of way, and offer more decentralized approaches to manage stormwater, increase flood storage, and restore ecosystems on public lands.

Green infrastructure, also referred to as “green stormwater infrastructure” (GSI) and “low impact development” (LID), is an alternative approach to traditional stormwater management. The GSI approach encourages the infiltration of stormwater into the ground close to where precipitation falls, similar to what occurs naturally in undeveloped areas. By using natural materials including vegetation and soils, these practices restore groundwater recharge and filtration processes while reducing downstream flooding and protecting water quality. Additionally, GSI can be constructed in stages, as funding and resources become available and as roads or Town buildings undergo repaving, renovation, or other upgrades. Unlike traditional underground drainage that needs to be constructed in whole to provide any benefit, GSI solutions can provide incremental benefits as they are implemented, allowing them to be phased in over time.

In addition to reducing polluted runoff and improving water quality, GSI can improve flow conditions in streams and rivers. Infiltrating water into the ground has the dual effect of reducing peak flows during wet weather events and sustaining or increasing stream base flow during dry periods, which can be important

for aquatic habitat, fisheries, and groundwater supplies. When applied throughout a watershed, GSI can help mitigate flood risk and increase flood resiliency. At a smaller scale, GSI can also reduce erosive velocities and streambank erosion. GSI and LID are the preferred approach for stormwater management in Massachusetts. Foxborough continues to undergo significant economic development and redevelopment, so there is an imminent need for sound, future-focused solutions to guide development in ways that consider future climate conditions, ongoing maintenance needs, and the needs of the Town’s climate vulnerable populations.

This Green Infrastructure Master Plan is intended to help our Town officials and other local decision-makers think more strategically about ways to utilize nature-based solutions to make our Town more resilient to future climate impacts—from flooding to extreme heat and drought—and to recognize key leverage points where projects can effectively benefit water quality and ecological health while simultaneously communicating proactive, climate resilient development strategies to residents.

The plan is the culmination of a year-long process of assessing potential GSI sites and project ideas throughout the Town. It includes:

- Prioritized site-specific and Town-wide recommendations,
- 10 Nine concept-level designs to support future implementation projects
- Standard engineering details for low-maintenance green infrastructure GSI stormwater controls tailored to the needs of Foxborough that could be implemented by the Town Department of Public Works (DPW) in a variety of locations
- Potential funding sources for design, permitting, and implementation of recommended projects



# What is Green Infrastructure?

Green stormwater infrastructure refers to systems and practices that reduce stormwater runoff through use of vegetation, soils, and natural processes to manage water and create healthier urban and suburban environments. These practices capture, manage, and/or reuse rainfall close to where it falls, reducing stormwater runoff and keeping it out of drainage systems and receiving waters.

## Green Infrastructure:

- Mitigates flooding & increases flood resiliency
- Reduces peak flows during storms
- Reduces pollutants in stormwater runoff, improving water quality
- Helps sustain stream flow during droughts
- Reduces streambank erosion
- Is more cost-effective than traditional drainage
- Improves air quality
- Sequesters carbon
- Helps reduce energy consumption
- Adds aesthetic interest
- Improves property values
- Contributes to overall economic vitality
- Promotes adaptation to climate change



Rain Gardens



Bioswale



Parking ROW Bioretention

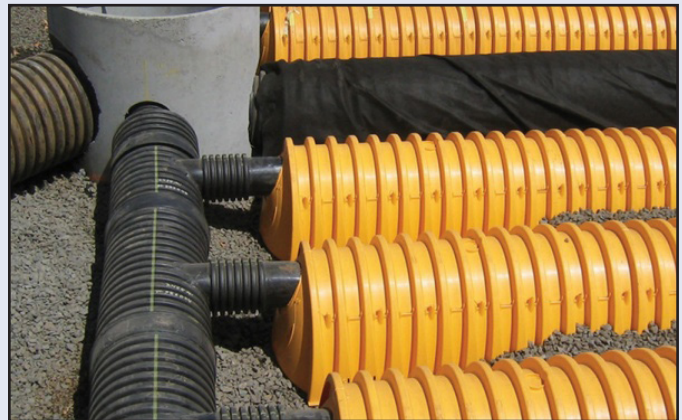

Infiltration Chambers

## 2 Current Conditions

### 2.1 Undersized and Aging SW Infrastructure

The Town of Foxborough operates an extensive drainage network to collect and convey stormwater, consisting of over 2,200 catch basins (inlets from the roadway into the underground drainage system), 50 miles of drainage pipe, and nearly 300 outfalls where stormwater is ultimately conveyed to streams and wetlands. Much of this infrastructure is past its intended design lifespan, and was designed for smaller, less intense storms than are predicted to impact Foxborough under future climatic conditions. As precipitation events become more intense and less predictable, undersized and aging stormwater infrastructure is expected to pose a greater threat

of failure and flooding. Catch basins can be overwhelmed, and even where drainage pipes are of adequate size, high volume stormwater flows can result in powerful erosive forces and scouring at outfalls, with corresponding impacts to natural streams.

High volumes of stormwater runoff also increase peak flows through downstream culverts and bridges, increasing the likelihood of road washouts or structural failure at inadequate or undersized road-stream crossing structures and significantly impacting the transportation system.

### Cocasset Street Underpass

In tandem with the development of this plan, the Town's MVP grant also funded a more detailed feasibility assessment of GSI solutions for the Cocasset Street railroad underpass. The area draining to the Canoe River adjacent to the Cocasset Street railroad underpass frequently floods. It is undersized to handle rain storms greater than 1", and is likely undersized during smaller-scale storms (<0.5"). The feasibility assessment included siting of GSI practices, modeling of the drainage network, infiltration testing and conceptual designs to a level that will support permitting for a future phase of implementation.





## 2.2 Improving Stormwater Protects Valuable Resources

When rain falls from the sky, it is generally clean. However, as soon as a raindrop hits the ground and starts flowing across surfaces, it begins collecting other materials. Stormwater runoff picks up surface pollutants like bacteria, nutrients, and sediment, carrying them into natural waterbodies, often without an opportunity for effective treatment and/or filtration. This can lead to degraded water quality, also referred to as “impairments,” resulting from excessive levels of phosphorus, nitrogen, sediments and solids, salts, bacteria, and other pollutants.

The Massachusetts Department of Environmental Protection tracks water quality in streams, ponds, and lakes around the Commonwealth. Within Foxborough, the Neponset Reservoir is listed as impaired due to high levels of algae and elevated turbidity, resulting from both stormwater and historic industrial discharges. The Neponset River is listed as impaired due to high levels of also has several listed impairments. Listed impairments such as phosphorus, E. coli, nutrients and eutrophication all are attributable to stormwater pollution.

Foxborough also sits on top of the Head of the Neponset Aquifer, serving the communities of Foxborough, Walpole, Medfield, Westwood, and Dover, as well as the Canoe River Aquifer, which serves the communities of Sharon, Mansfield, Easton, and Norton. Both aquifers are designated by the U.S. Environmental Protection Agency as Sole Source Aquifers, which means that the aquifer supplies at least 50% of the drinking water for its service area, and that there are no other reasonably available alternative drinking water sources to fall back on should the aquifer become contaminated. Green infrastructure GSI practices like those identified in this plan help to protect the quality of our drinking water by promoting infiltration of stormwater to recharge the aquifer and by treating stormwater pollutants before they make their way into groundwater.

### Common Groundwater Pollutants

- Nitrogen
- Phosphorus
- Organic debris
  - *Leaves, lawn clippings*
- Sediment
  - *Sand and road grit*
- Pathogens
  - *Bacteria*
  - *Animal wastes*
- Metals
- Organic chemicals
  - *Pesticides, herbicides*



# 3 Climate Change Impacts to Foxborough

Both the acute and chronic impacts associated with extreme weather and natural and climate-related hazards are an increasing concern for the communities of Southeastern Massachusetts. When the Town conducted a Community Resilience Building (CRB) workshop as the first step in its climate resilience planning process, Town stakeholders identified flooding and severe storms as two of the top climate change-related hazards facing the Town. The threat from flooding has been growing with the increasing frequency of major storm events that deliver large amounts of precipitation over a short time period, and this threat is expected to continue to grow due to climate change. Here in Foxborough over the past 60 years, there has already been more than a doubling of heavy rainstorms.

As time goes on, Foxborough's climate will begin to look more like the climate in the mid-Atlantic. By the end of the century, our climate here in southeastern Massachusetts will feel like that of the Carolinas today - in other words, we're looking at a hotter, wetter future.

The Northeast Climate Adaptation Science Center at the University of Massachusetts Amherst projects that, given a medium to high future emissions scenario, Foxborough will see as much as 8 additional inches rainfall per year by the end of the century. More critically in terms of flood potential, the Town could see up to 4.7 additional days with precipitation over one inch. Similarly, the Massachusetts Department of Transportation (MassDOT)<sup>1</sup> projects that by 2070 the 100-year, 24-hr rainfall event in the Neponset River Basin, will increase up to 20% under a medium emissions scenario (RCP6.0) and up to 30% under a high emissions or business-as-usual scenario (RCP8.5). This is consistent with the broader findings of the 4th National Climate Change Assessment that identified a 55% increase in the total annual precipitation falling in the heaviest 1% of events in the period 1958-2016 and anticipates an up to 40+% change by late century under a high emissions scenario. With higher annual temperatures and warmer winters, more precipitation will be falling in the form of rain, generating more runoff.

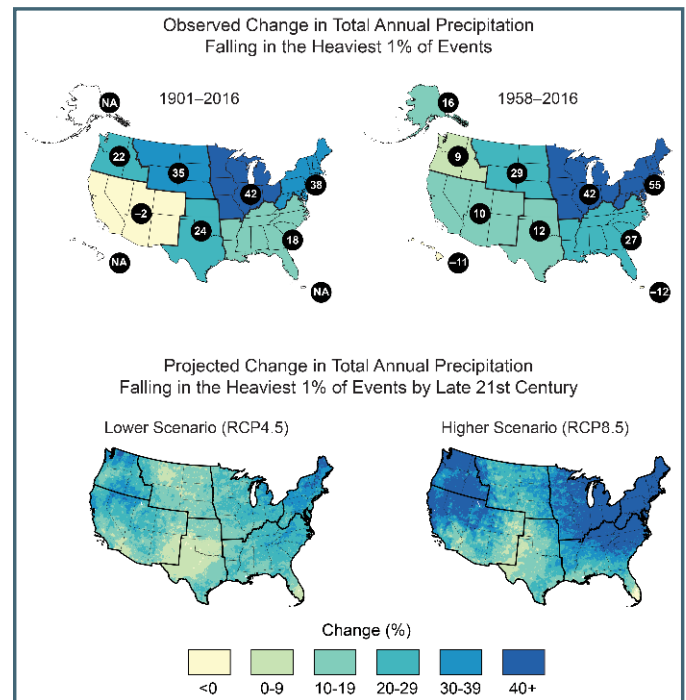
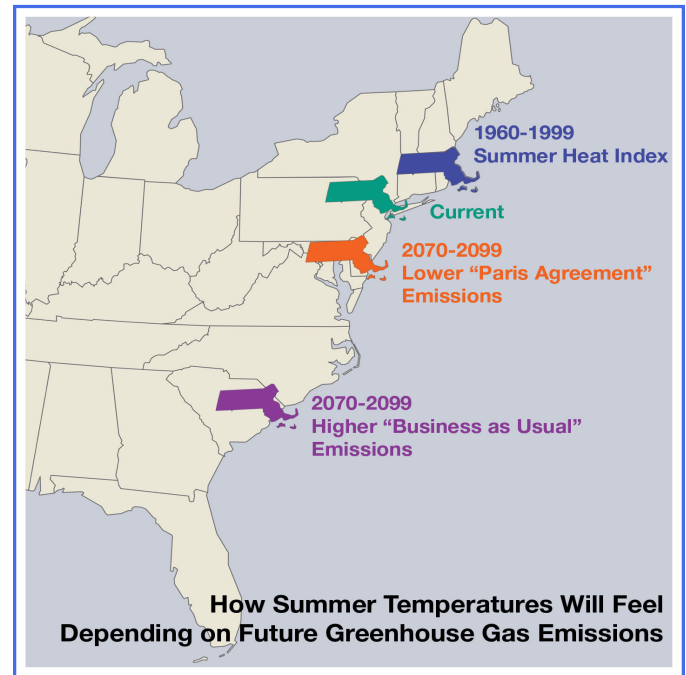

*Observed and Predicted Extreme Precipitation (4th National Climate Assessment; <https://nca2018.globalchange.gov/chapter/2/>)*

<sup>1</sup> <https://gis.massdot.state.ma.us/cpws/>

### 3.1 What Climate Change Means for Stormwater

As precipitation events become more intense and less predictable, undersized and aging stormwater infrastructure is expected to pose a greater threat of failure and flooding. Over the past decade, high intensity rain events have increasingly caused roadway flooding at the Cocasset Street underpass, Chestnut Street, and at the Public Works facility. Increased precipitation intensity means catch basins and undersized pipes will be increasingly overwhelmed, leading to more frequent roadway flooding. Even where drainage pipes are of adequate size, high volume stormwater flows can result in powerful erosive forces and scouring at outfalls, with corresponding impacts to natural streams. Areas with large amounts of impervious cover, including parking lots, roof tops, roadways, driveways, and patios, that don't allow stormwater to infiltrate into the ground, generate high volumes of stormwater runoff. High volumes of stormwater runoff also increase peak flows through downstream culverts and bridges, increasing the likelihood of road washouts or structural failure at inadequate or undersized road-stream crossing structures and significantly impacting the transportation system both within and downstream of Foxborough.



*Flooding at the Foxborough Highway Department facility*

### 3.2 Water Quality and Climate Change

As noted above, stormwater runoff carries sediment, bacteria, and nutrients like phosphorus and nitrogen into surface water bodies. As climate change progresses, the increased frequency and intensity of precipitation events that lead to greater stormwater runoff volumes are also expected to increase nutrient pollutant loads delivered to Foxborough's lakes and rivers. Increased storm intensity leads to greater erosion potential of nutrient-laden soils and sediment, and delivery of more bacteria from animal and human waste. Higher temperatures predicted with climate change, coupled with increased nutrient levels in stormwater runoff, can further worsen water quality in Foxborough's water bodies. The Neponset and Taunton River Basins are expected to see increases in days over 90° of up to 77 additional days by the 2090s, and consecutive dry days between rain events are estimated to increase to 17 days annually by the end of the century.<sup>2</sup>



*Pollutant sources and stormwater*

*Credit: Metropolitan North Georgia Water Planning District*





*Algae blooms can lead to fish kills  
Credit: Tom Archer*



Together with increased pollutant loads, this creates conditions for cyanobacteria to grow and reproduce to potentially dangerous levels, as they did in 2020 at Lake Mirimichi. These harmful algal blooms and other public health advisories are expected to become increasingly frequent as climate change leads to more extreme heat conditions and drought periods. A nationwide screening-level assessment of climate impacts on cyanobacteria harmful algal bloom prevalence determined that the largest increases in harmful algal bloom occurrence were likely to occur in the Northeast.<sup>3</sup> Algal bloom die offs in turn reduce dissolved oxygen levels in lakes and rivers, leading to fish kills.

<sup>2</sup> Northeast Climate Adaptation Science Center and Resilient MA Climate Data Clearinghouse

<sup>3</sup> Chapra, SC et al. 2017. Climate change impacts on harmful algal blooms in US freshwaters: a screening-level assessment. *Environmental Science and Technology* 51: 8933-8943.

# 4 Prioritized Green Infrastructure Concepts

## 4.1 Site Selection and Assessment Process

Sites throughout Foxborough were screened for GSI opportunities or other nature-based solutions to increase flood resiliency and improve or protect water quality. A desktop screening process was initially performed using geographic data layers to identify locations with the greatest risk from flooding and potential for water quality benefits from GSI retrofits. This screening-level review considered the following factors:

- Municipal ownership (parcels and right of ways)
- Flood-prone areas
- Water quality impairments
- Soil infiltration capacity
- Open space priorities
- Aquifer and wellhead protection areas
- Utility information (particularly existing drainage infrastructure)
- MS4 regulated areas

Initial sites identified in the screening-level review were presented to and reviewed by the Steering Committee to incorporate information and institutional knowledge from Town staff and other stakeholders. The list of potential sites was also examined relative to ongoing planning and capital projects in the Town to identify project sites where GSI could be incorporated in a cost-effective manner as part of a larger project (e.g., planned future redevelopment projects or repaving). Sites with the highest potential for cost-effective GSI retrofits were selected by the Steering Committee for field inventories.

Field inventories were then performed at selected sites to further evaluate the feasibility of implementing GSI retrofits or nature-based solutions at each location. Field assessments focused on adjacent land use and development characteristics, areas of impervious surfaces, drainage patterns and

approximate drainage areas, the presence and locations of utilities, locations for potential stormwater retrofits, and site constraints such as evidence of shallow groundwater or bedrock that could limit the feasibility of infiltration-based practices.

The GSI concepts presented in this master plan were reviewed and selected by the Steering Committee as the most promising candidates for GSI improvements that would yield significant benefits in terms of flooding and climate resilience as well as improved water quality. Many of the selected sites are also priority areas for either DPW or Planning for future improvements within the next several years.

Each concept includes calculations of the volume and depth of stormwater runoff that could be captured by the proposed GSI practices. Calculations of potential pollutant load reductions for total suspended solids (sand, grit, etc.), nutrients (phosphorus and nitrogen) and bacteria were calculated for each practice based on GSI performance curves published by the University of New Hampshire Stormwater Center and the U.S. Environmental Protection Agency.<sup>4</sup> Order of magnitude costs were also developed based on the calculated volume of water to be treated at each site and typical unit costs for constructing GSI practices. A more detailed summary of cost calculations and assumptions is provided after the concepts.

<sup>4</sup> [https://www.unh.edu/unhsc/sites/default/files/media/ms4\\_permit\\_nomographs\\_sheet\\_final\\_2020.pdf](https://www.unh.edu/unhsc/sites/default/files/media/ms4_permit_nomographs_sheet_final_2020.pdf)

<https://www.epa.gov/sites/production/files/2020-01/documents/tisbury-subtask-4d-tm.pdf>



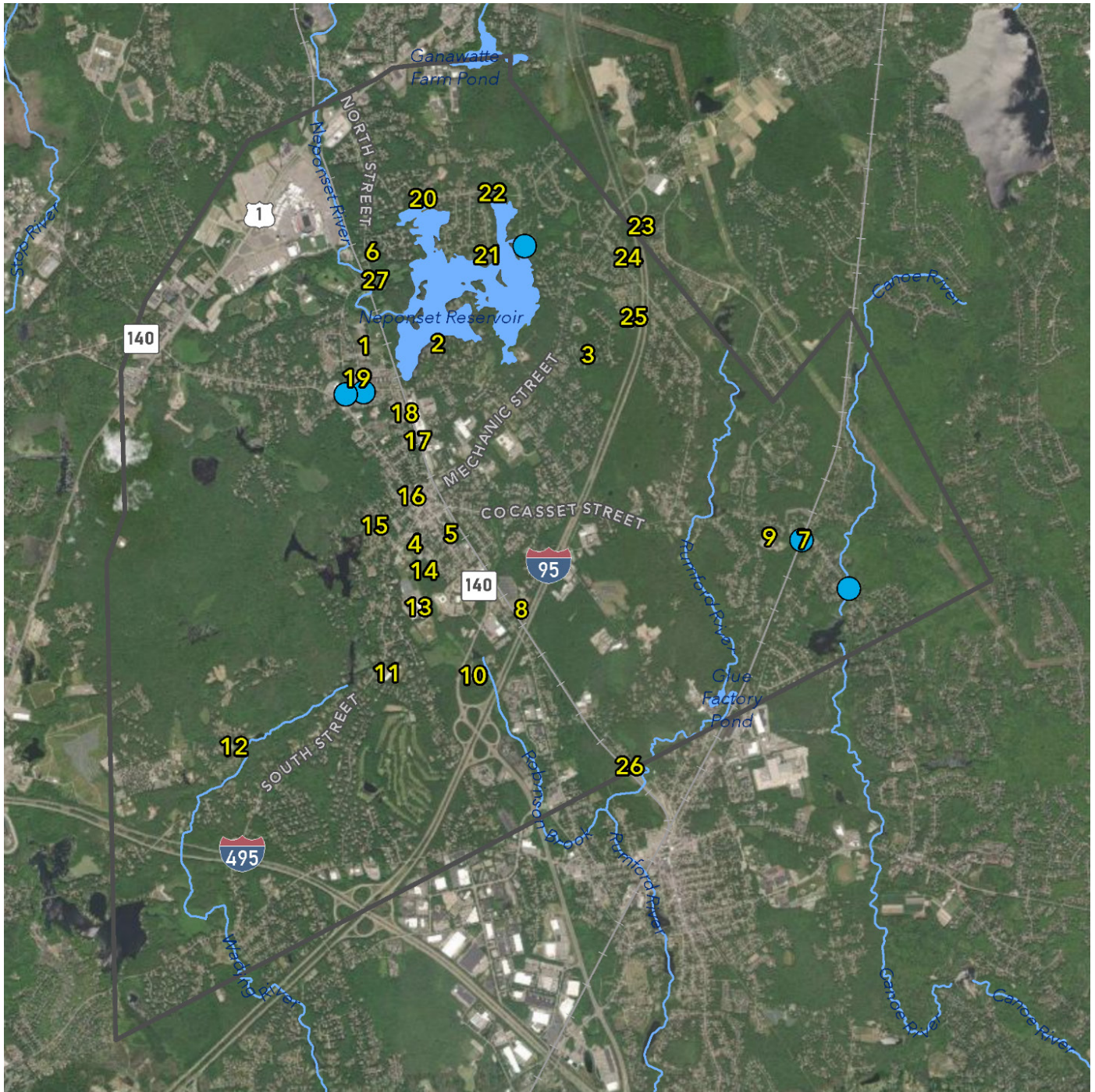

- |   |                                       |                                 |
|---|---------------------------------------|---------------------------------|
| <b>1</b> Payson Road Recreation Complex (3) | <b>11</b> Taylor Elementary School    | <b>21</b> Shoreline Drive       |
| <b>2</b> Kersey Point Conservation Area     | <b>12</b> Cocasset River Park         | <b>22</b> Edwards Road          |
| <b>3</b> Sunset Estates (2)                 | <b>13</b> High School                 | <b>23</b> Reynolds Dr           |
| <b>4</b> Igo Elementary School              | <b>14</b> Booth Playground            | <b>24</b> Louise Drive          |
| <b>5</b> Council on Aging                   | <b>15</b> Centennial Court            | <b>25</b> Walden Farms Road     |
| <b>6</b> Lane Homestead                     | <b>16</b> Downtown Parking            | <b>26</b> Commuter Rail Parking |
| <b>7</b> Cocasset Street Underpass          | <b>17</b> Railroad Avenue             | <b>27</b> McKenzie Lane         |
| <b>8</b> Dept. of Public Works              | <b>18</b> N. Carl Annon Court         |                                 |
| <b>9</b> Burrell Elementary School          | <b>19</b> Social Hall, State Hospital |                                 |
| <b>10</b> Walnut Street                     | <b>20</b> Young Road                  |                                 |

**Bold sites indicate conceptual design**

 Known Flooding Areas



# 4.1.1 Payson Road Athletic Complex – North Parking Lot

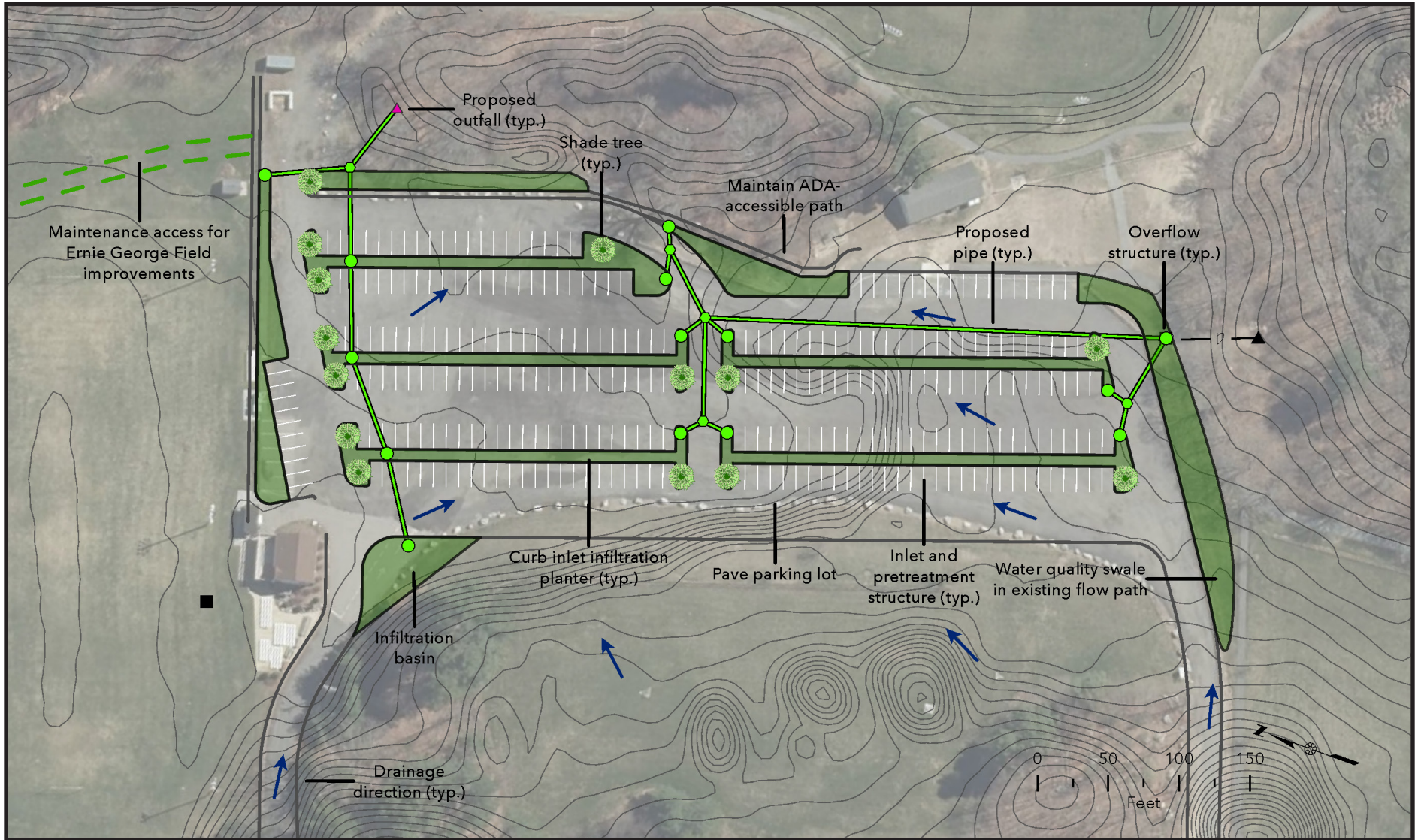

## Site Description

The Payson Road Athletic Complex provides space for Foxborough residents to participate in football, baseball, soccer, basketball, and lacrosse. The existing, compacted-gravel north parking lot at the Payson Road Athletic Complex does not have stormwater infrastructure presently. As a result, stormwater has eroded a channel from the parking lot into nearby wetlands. The Town paints lines onto the existing gravel parking area to guide facility users, yielding approximately 275 parking spaces. Soils in the area generally support infiltration-based practices with high pollutant removal potential. Infiltration testing would need to be done prior to final design to determine actual infiltration rates, or if insufficient, determine if the design needs to be modified to incorporate underdrains.



## Proposed Green Infrastructure Concept:

- Reconfigure the parking lot to include longer parking bays, with curb-inlet infiltration practices between parking rows.
- Formalize parking lot with curbing and pavement to aid directing water to predetermined locations where pretreatment will occur removing sediment.
- Reconfiguring parking lot layout to formalize traffic patterns and provide up to an additional 18 parking spaces over the existing layout
- Install an infiltration basin along both the north and south entrance roads of the parking lot to capture runoff from the two entrances
- Improve the existing connection between fields along the eastern edge of the parking lot by constructing an ADA-accessible path
- Provide informational signage along the path to educate facility users about the infiltration practices and the Town's commitment to addressing vulnerability to climate-related hazards.

### Site Data

Impervious Area Treated:	3.5 acres*	Estimated Cost:	
Design Storage Volume:	26,800 ft <sup>3</sup>	\$525,000 Drainage improvements	
Runoff Capture Depth:	2.0 inches	\$675,000 Parking lot improvements	

### Pollutant Removal:

Total Suspended Solids	Phosphorus	Nitrogen	Bacteria
100	100	100	99

\* If all practices are installed



## 4.1.2 Payson Road Athletic Complex – South Parking Lot

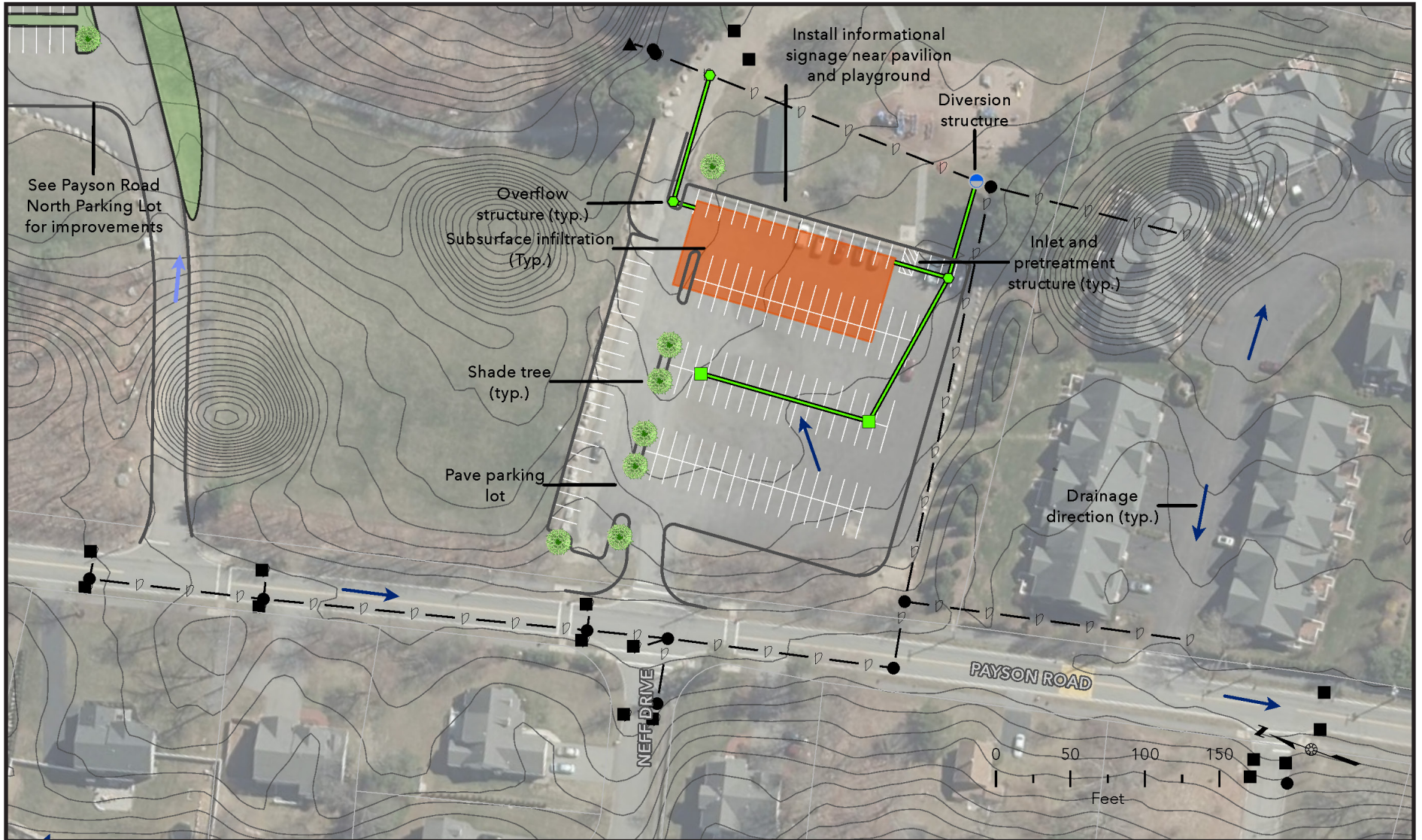

## Site Description

The south parking lot of the Payson Road Athletic Complex is a compacted-gravel parking lot. The Town paints lines onto the existing parking area to guide Complex users, yielding approximately 125 parking spaces. In addition, the parking lot does not have stormwater infrastructure. As a result, untreated stormwater currently flows into a channel from the parking lot into nearby wetlands. Additional runoff from the surrounding neighborhoods of Payson Road, Neff Drive, and Capone Road are conveyed in pipes around the parking lot, discharging to the wetlands and Crackrock Pond. This piped stormwater network is more challenging to treat but could increase the amount of stormwater that is able to be treated here significantly. Soils in the area should generally support infiltration-based practices with high pollutant removal potential. Infiltration testing will be an important next step to determine the best locations for GSI.

## Proposed Green Infrastructure Concept:

- Install subsurface infiltration chambers under the parking lot, with a diversion structure (e.g. weir) from the existing storm drain to convey flow from Payson Road, Neff Drive, and Capone Road.
- Formalize the parking layout with pavement, curbing, and catch basins. Direct water from the catch basins to the subsurface infiltration chambers. Plant shade trees in the curbed beds at the end of the parking rows.
  - *Underground infiltration treats the greatest volume of stormwater while maintaining the existing level of parking.*
- Provide informational signage near the playground and pavilion to educate Complex users about the location and function of the subsurface infiltration chambers, as well as the hazards posed by climate change and the Town's commitment to reducing climate vulnerability.

### Site Data

Impervious Area Treated: 1.2 acres parking lot  
2.3 acres neighborhood

Design Storage Volume: 19,500 ft<sup>3</sup>

Runoff Capture Depth: 1.2 inches

#### Pollutant Removal:

Total Suspended Solids	Phosphorus	Nitrogen	Bacteria
100	100	100	99

#### Estimated Cost:

\$1,600,000 Drainage improvements  
\$250,000 Parking lot improvements



### 4.1.3 Payson Road Athletic Complex – Ernie George Field

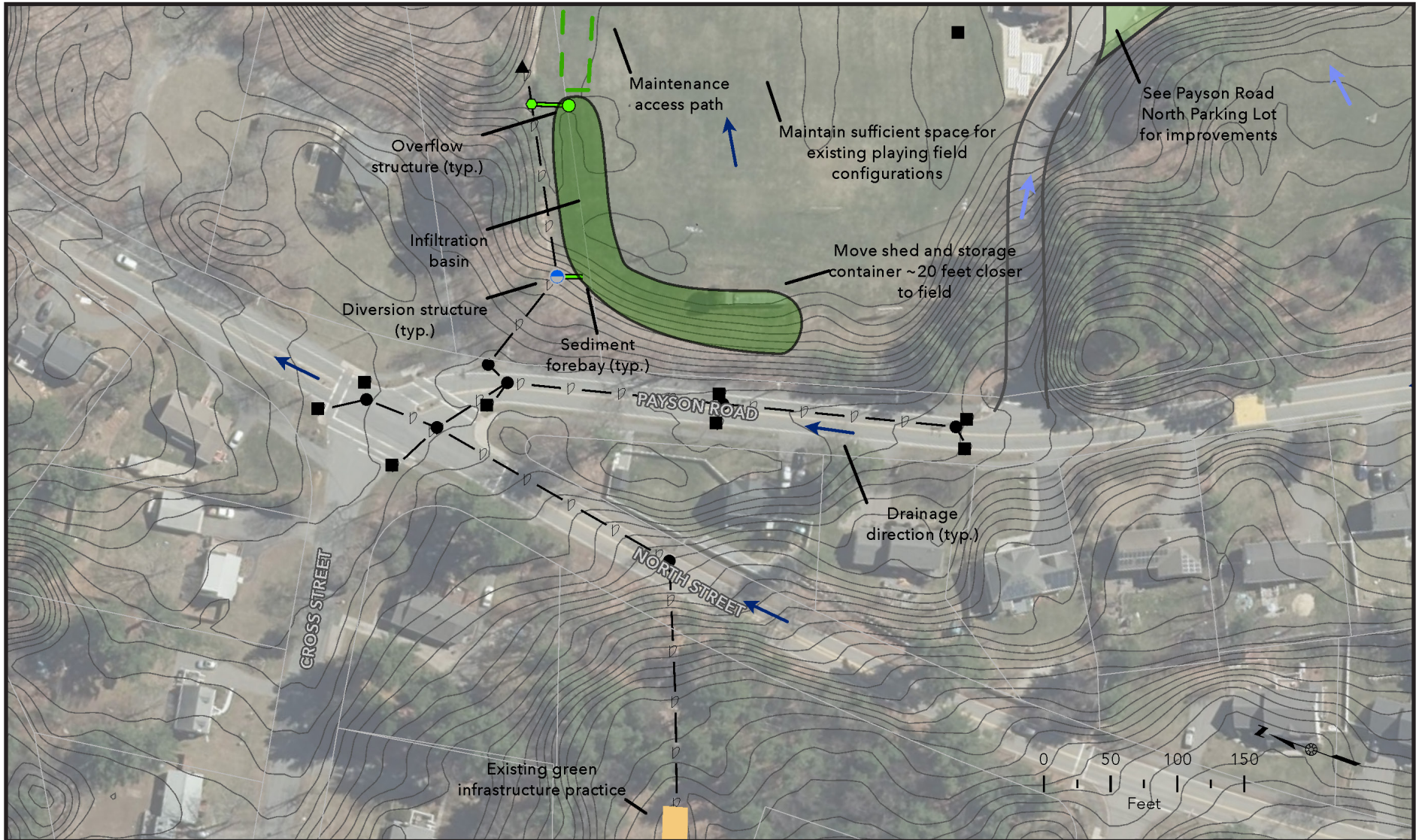

## Site Description

Located at the north end of the Payson Road Athletic Complex, Ernie George Field provides space for football and lacrosse fields. The field features stadium lighting and an electronic scoreboard. Runoff from the North Road and Payson Road collects in catch basins and is conveyed under Ernie George Field by an existing stormwater pipe. Stormwater currently discharges directly into Crackrock Pond, which currently faces nutrient-related algal blooms and the Neponset River, which is impaired for bacteria. The field is a terrace between Payson Road above and the wetland below. Soils in the area generally support infiltration-based practices with high pollutant removal potential.



## Proposed Green Infrastructure Concept:

- Construct an infiltration basin in the open space between Payson Road and the football field to infiltrate the water quality volume. Retrofit the existing junction manhole near the northwest corner of the field to a weir or similar diversion structure to divert the design volume to the basin.

### Site Data

Impervious Area Treated:	2.37 acres	Estimated Cost: \$150,000
Design Storage Volume:	10,509 ft <sup>3</sup>	
Runoff Capture Depth:	1.2 inches	

### Pollutant Removal:

Total Suspended Solids	Phosphorus	Nitrogen	Bacteria
100	98	100	97



4.1.4  
Kersey Point Conservation Area

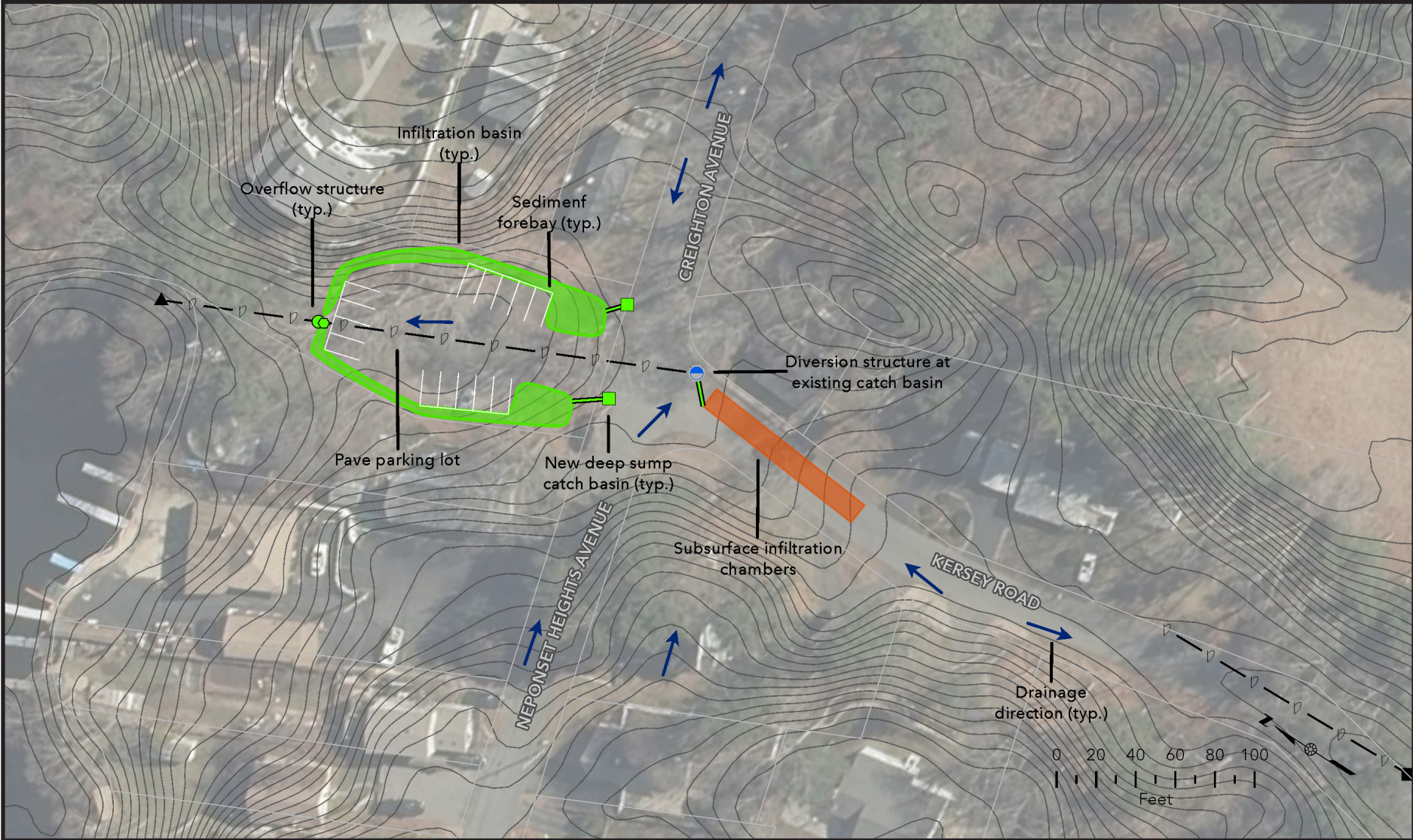

## Site Description

Kersey Point Conservation Area on the shore of the Neponset Reservoir is located at the intersection of Kersey Road, Neponset Heights Avenue, and Creighton Avenue. A short, one-lane road provides access down an approximately 4-foot drop to a small, compacted-dirt parking lot. Two catch basins along Kersey Road discharge via a 12" corrugated metal pipe under the parking lot to the Neponset Reservoir. Runoff from the north side of Neponset Heights Avenue and Creighton Avenue flow down the slope and across the dirt parking lot to the Reservoir. Although soils in the area generally support infiltration-based practices, the proximity of the Neponset Reservoir suggests shallower depth to groundwater at the parking lot, which may limit the feasibility of such practices the closer to the reservoir they are installed.

## Proposed Green Infrastructure Concept:

1. Install a subsurface infiltration practice under the intersection to treat stormwater from Kersey Road and Neponset Heights Avenue.
  2. Install infiltration basins on both sides of the parking lot entrance between the parking area and parcel boundary.
    - *Conduct infiltration testing to identify the depth to seasonal high groundwater. If there is insufficient depth to groundwater to install an infiltration practice then a lined bioretention practice could be substituted.*
- Install deep sump catch basins in the roadway above the parking area to divert the water quality volume from the roadway to the infiltration basins.
  - Pave and stripe the parking lot, regrading to direct stormwater to the infiltration basins.
  - Convey water in excess of the design volume to a drainage swale around the parking area, overflowing to the existing drainage pipe.
  - Replace poor condition existing pipe with a larger, more durable HDPE or concrete pipe.
  - Where feasible maintain existing trees.

### Site Data

Impervious Area Treated:	1.08 acres	Estimated Cost:	\$335,000
Design Storage Volume:	4,452 ft <sup>3</sup>	Subsurface infiltration:	\$210,000
Runoff Capture Depth:	1.1 inches	Infiltration basin:	\$55,000

### Pollutant Removal:

BMP	Total Suspended Solids	Phosphorus	Nitrogen	Bacteria
Subsurface Infiltration	100	100	100	99
Infiltration Basin	99	53	32	55



4.1.5  
Sunset Estates

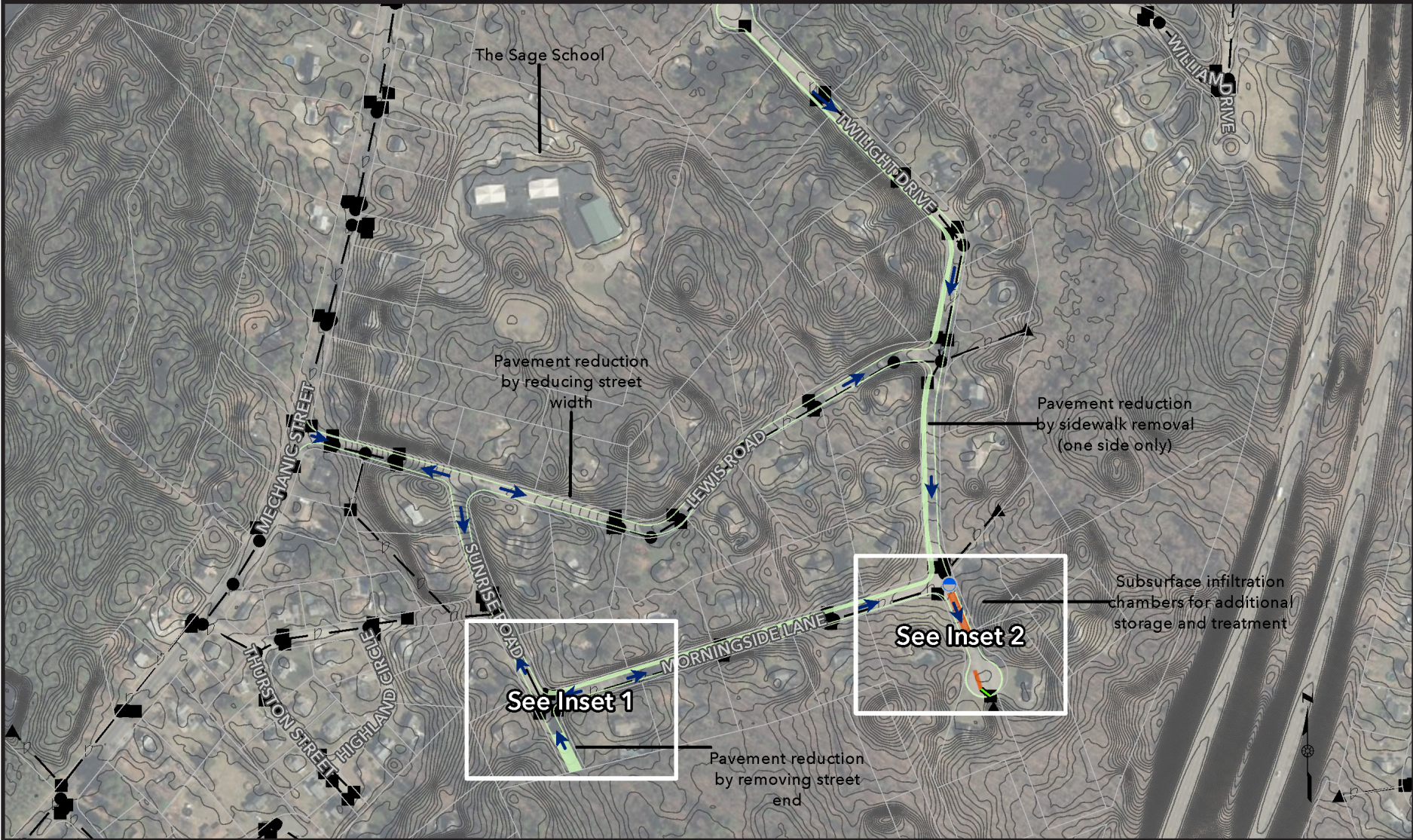



### Inset 1: Sunrise Road

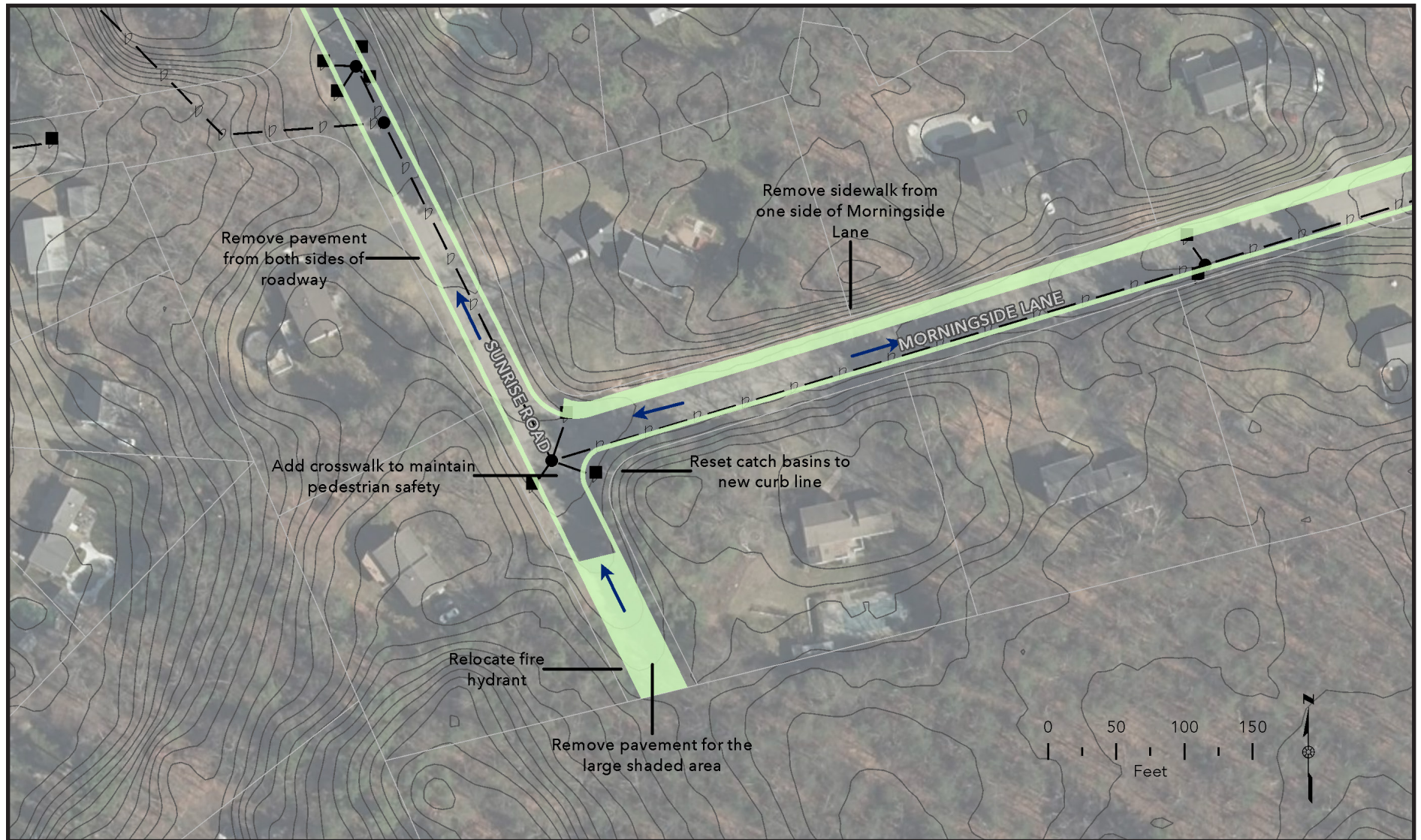



Inset 2: Twilight Drive

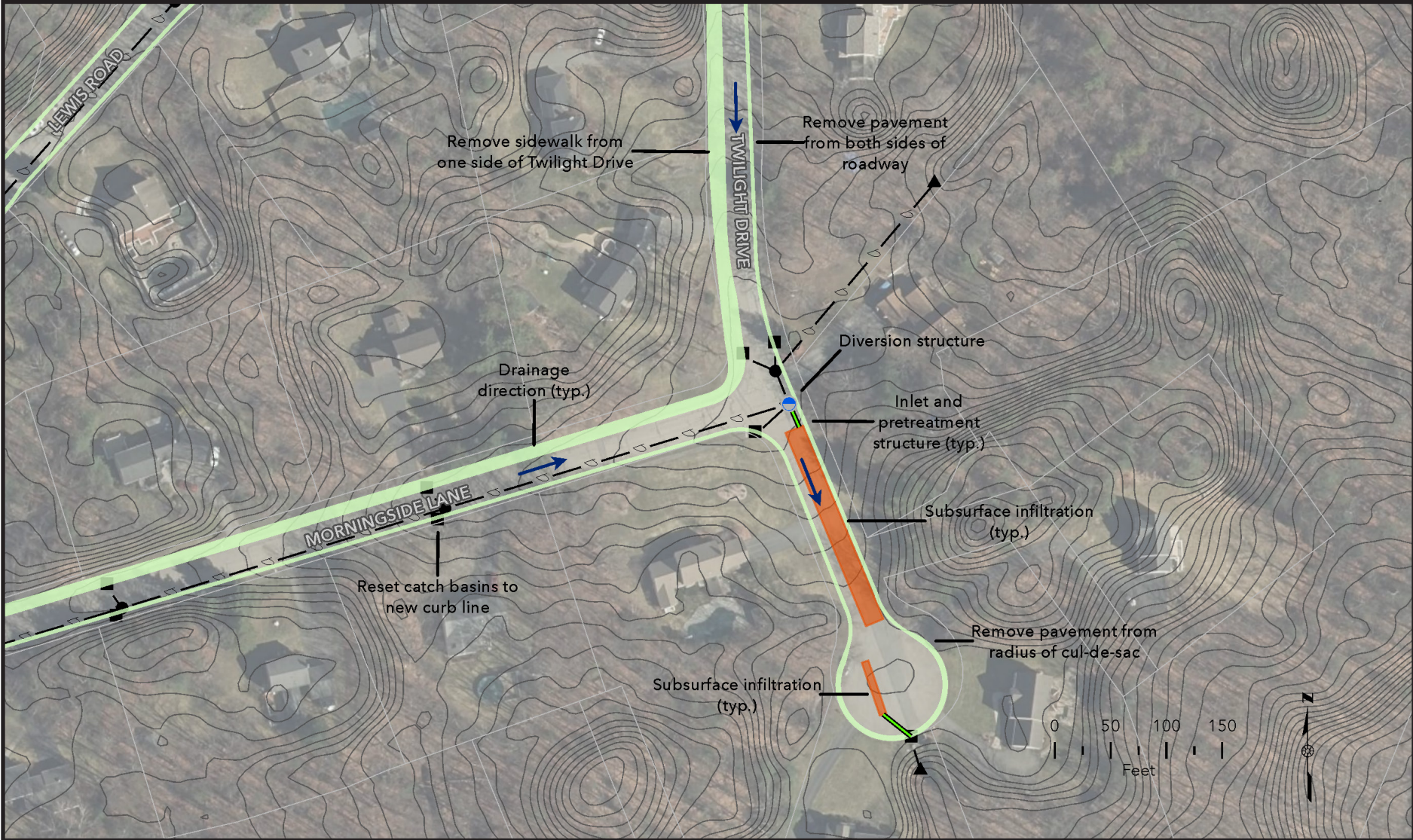

## Site Description

The streets that make up the Sunset Estates subdivision, including Lewis Road, Twilight Drive, Morningside Lane, and Sunrise Road, are approximately 33 feet wide. This width of paved road goes beyond the amount of space needed to allow traffic and emergency vehicles to pass. Sidewalks, with buried utilities beneath, run along both sides of the street. Conventional storm drains are also present, with catch basins regularly spaced along both sides of the crowned roadway. On-street parking was not observed during field visits to the subdivision and conversations with the Steering Committee confirmed these observations. Soils in the area generally support infiltration-based practices, although sporadic rock outcrops mapped in the area may limit feasibility. Infiltration testing will be required to determine actual suitability.

## Proposed Green Infrastructure Concept:

- Reduce pavement width by 3.5 feet on either side of each street in the subdivision, and reduce the paved radius of cul-de-sacs by 5 feet. Restore infiltrative capacity of underlying soil by decompaction. Reset curbs and catch basins as necessary.
- Remove the 112-foot length of pavement at the end of Sunrise Road.
  - *Relocate the hydrant at the end of Sunrise Road to the new end of the street.*
- Remove sidewalk on the north side of Morningside Lane and the west side of Twilight Drive.
  - *Add crosswalks where sidewalk removal would require street crossing to maintain pedestrian safety.*
- Install subsurface infiltration chambers under Twilight Drive south of the intersection with Morningside Lane (1) and under the southern cul-de-sac on Twilight Drive (2). Use a weir or similar diversion structure to direct stormwater to each practice.

### Site Data

Impervious Area Treated:	1.43 acres	Estimated Cost:	\$900,000
Design Storage Volume:		Pavement Removal:	\$30,000
Pavement Removal:	4,948 ft <sup>3</sup>	Subsurface infiltration:	\$600,000
Subsurface Infiltration:	6,500 ft <sup>3</sup>		

### Pollutant Removal:

BMP	Total Suspended Solids	Phosphorus	Nitrogen	Bacteria
Pavement Removal	N/A	2.8 lb/yr	N/A	N/A
Subsurface Infiltration	98	82	95	80



4.1.6  
Igo Elementary School

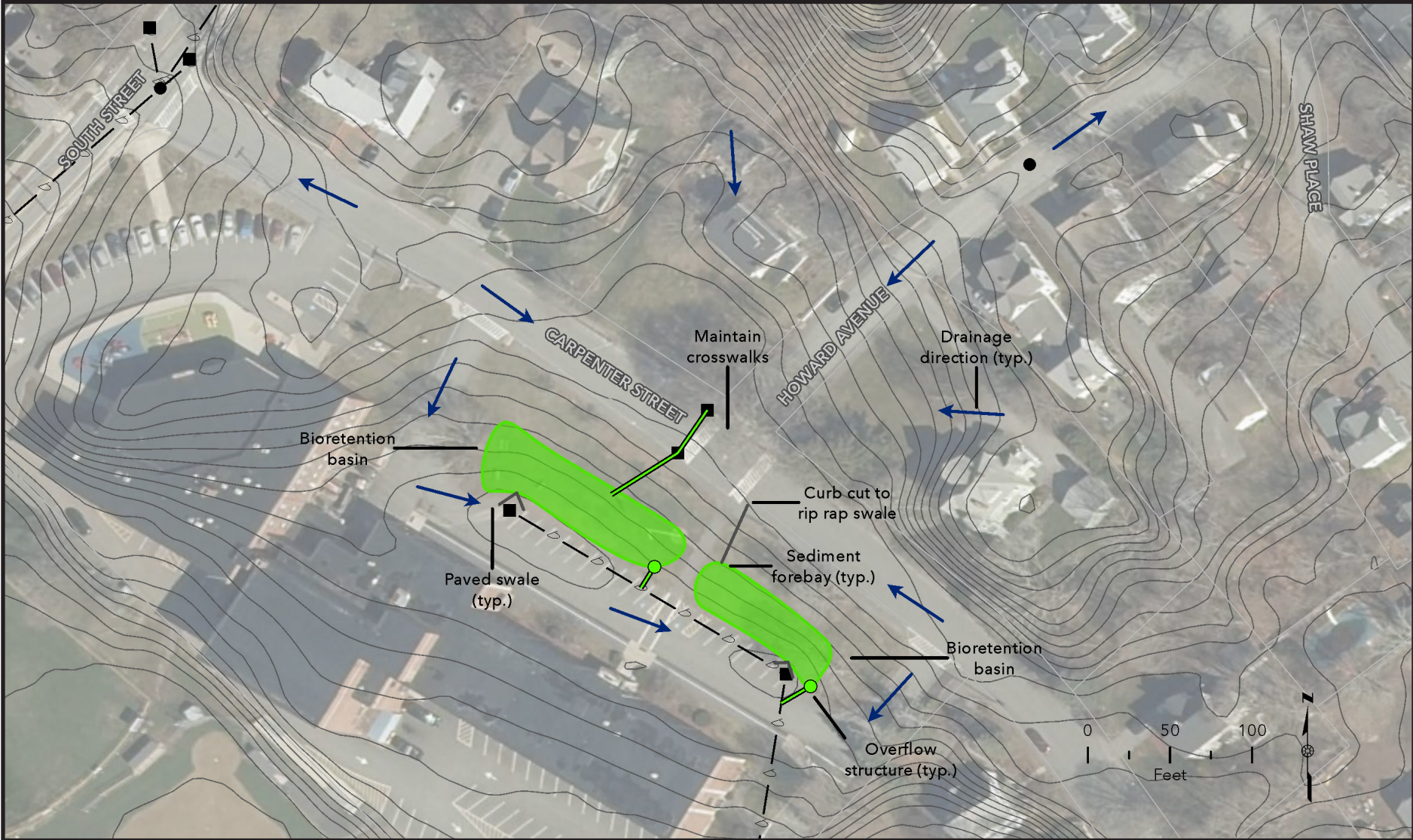

## Site Description

Vincent M. Igo Elementary School is located near downtown Foxborough and the intersection of South Street and Carpenter Street. The intersection of Carpenter Street and Howard Avenue at the front of the school is approximately 33 feet wide and includes three crosswalks. Two catch basins at the northwest side of the intersection are believed to convey runoff around the school and toward a tributary of Robinson Brook behind Booth Fields. Gas and water utilities were observed within the right-of-way. Sidewalks are located on both sides of the streets. Soils in the area are mapped as Woodbridge-Urban land complex, which may have a firm and platy structure that can inhibit the infiltration rate of the native soil.



## Proposed Green Infrastructure Concept:

1. Install bioretention areas with native plantings in the open space at the front of the school to infiltrate stormwater from the school's front parking area and Howard Avenue
- Construct two catch basins at the southeast side of the intersection to address intermittent flooding and to act as overflow structures
  - Relocate existing flagpole closer to street
  - Move picnic tables under large tree at north end of parking lot

### Site Data

Impervious Area Treated: 1.89 acres  
 Design Storage Volume: 7,064 ft<sup>3</sup>  
 Runoff Capture Depth: 1.0 inches

Pollutant Removal:

Total Suspended Solids	Phosphorus	Nitrogen	Bacteria
99	53	32	55

Estimated Cost: \$115,000



4.1.7  
Council on Aging

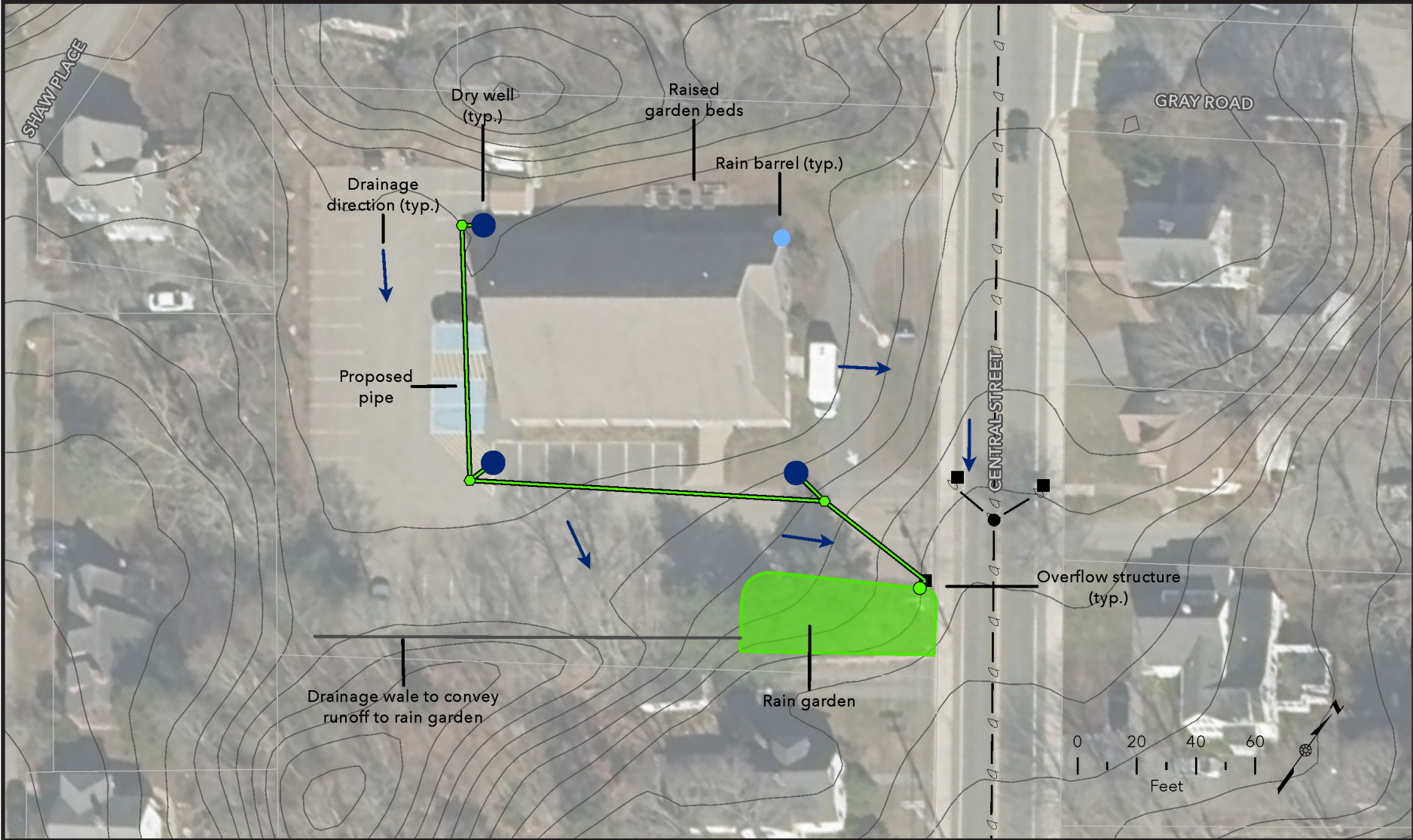

## Site Description

The Council on Aging Senior Center on Central Street south of downtown Foxborough includes a 42-space parking lot, which slopes toward the parcel's southern boundary. In past, stormwater flowed erosively along the southern boundary, which is now lined with 2-inch stone as a rip rap swale. Conversations with Senior Center staff indicated that the parking lot floods and runoff flows across landscaped bed located at the entrance to the parking lot. Roof downspouts were observed to be buried and are believed to connect to a catch basin located at the parking lot entrance. Three raised garden beds were observed at the rear of the building. Soils in the area are mapped as Woodbridge-Urban land complex, which may have a firm and platy structure that can inhibit the infiltration rate of the native soil.

## Proposed Green Infrastructure Concept:

1. Replace front landscaped bed with rain garden to infiltrate water quality volume. Direct overflow to nearby catch basin at parking lot entrance
2. Install precast leaching galleys at each downspout at the four corners of the building, directing overflow around building to existing catch basin at parking lot entrance
3. At the north corner downspout, install a rain barrel to provide water for the existing raised garden beds. Coordinate with Council on Aging staff to provide training on the correct maintenance schedule for the rain barrel.

### Site Data

Impervious Area Treated: 0.50 acres  
 Design Storage Volume: 6,210 ft<sup>3</sup>  
 Runoff Capture Depth: 1.0 inches

#### Pollutant Removal:

Total Suspended Solids	Phosphorus	Nitrogen	Bacteria
99	53	32	55

Estimated Cost: \$140,000



4.1.8

Lane Homestead Conservation Area

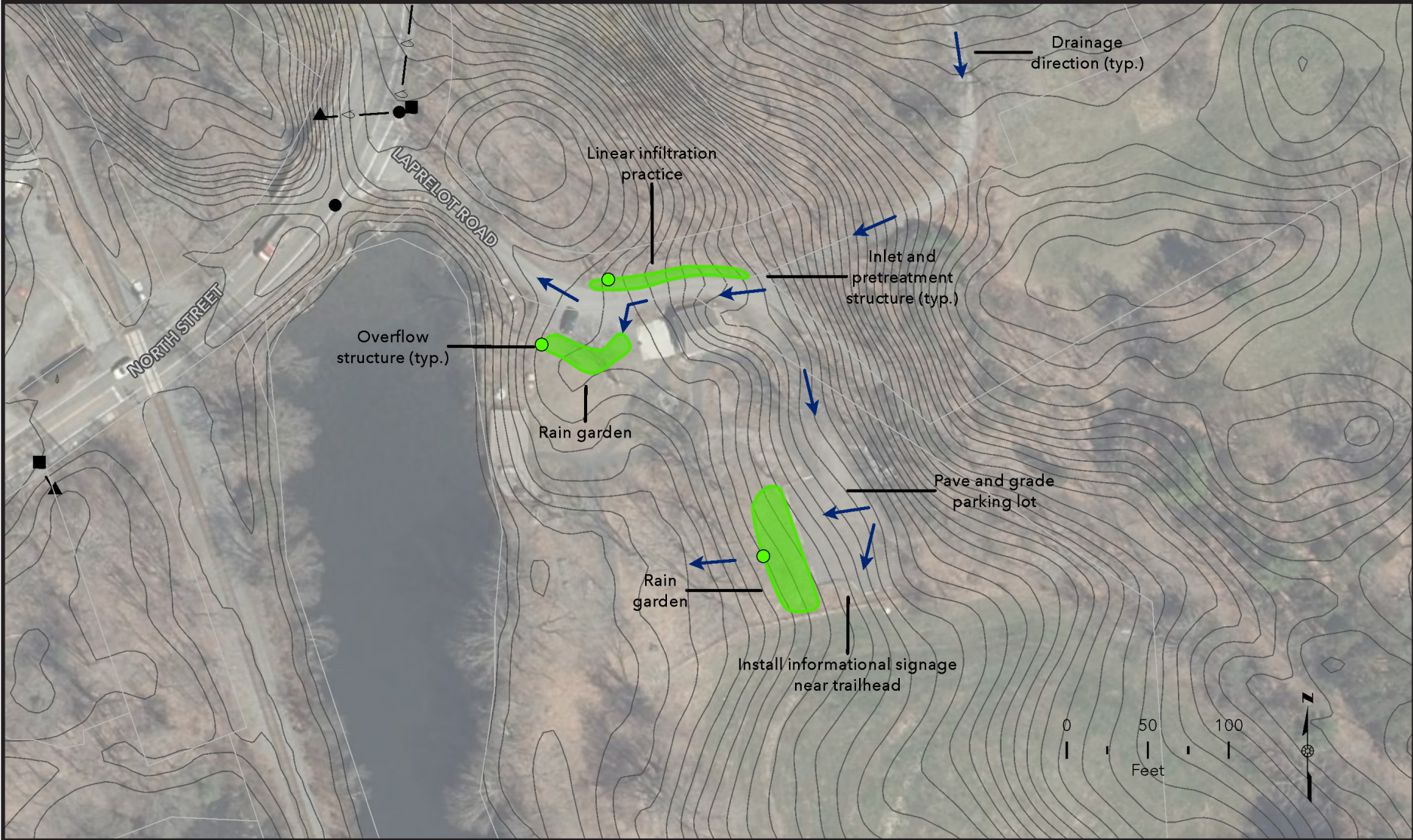

## Site Description

The Lane Homestead Conservation Area is one of several abutting Town conservation parcels located between the Neponset Reservoir and Crackrock Pond, comprising over 90 acres. The Lane Property includes the Lane Learning Center, which provides a venue for educational nature programming, and a compacted gravel parking lot for approximately 15 vehicles. Rain barrels have been installed at downspouts of the Learning Center, and a small rain garden captures runoff from the entrance to the property. A private property is located uphill of the Learning Center, accessible by a private driveway. Runoff from this developed area of the property discharges overland to Crackrock Pond. Soils in the area are mapped as Hinckley loamy sand, which generally support infiltration-based practices.

## Proposed Green Infrastructure Concept:

1. Construct a rain garden downgradient of the main parking area, using native plantings. The nearby mature maple trees are invasive and could be replaced with a native tree species. Use a level spreader or similar energy dissipation device to reduce erosion from runoff in excess of the design storage volume. Regrade and resurface the parking lot as necessary to reduce sediment load and to direct all runoff to the practice.
  2. Construct a linear infiltration practice north of the Learning Center and entrance to treat runoff from the private drive and entrance. Direct runoff in excess of the design volume to the open space to the north.
  3. Construct a rain garden in front of the Learning Center to capture runoff from the private driveway, property entrance, front parking area, and patio. Use a level spreader or similar energy dissipation device to reduce erosion from runoff in excess of the design storage volume.
- Given the educational purpose of the property and highly public location, install educational signage near each practice to demonstrate the value and benefits of the various installed practices, including the existing rain barrels, which can be effective for individual homeowners.

### Site Data

Impervious Area Treated: 0.23 acres  
 Design Storage Volume: 1,218 ft<sup>3</sup>  
 Runoff Capture Depth: 1.25 inches

#### Pollutant Removal:

Total Suspended Solids	Phosphorus	Nitrogen	Bacteria
100	98	100	97

Estimated Cost: \$20,000, does not include cost of paving parking lot



## 4.2 Cocasset Street Green Infrastructure Conceptual Designs and Cost Estimates

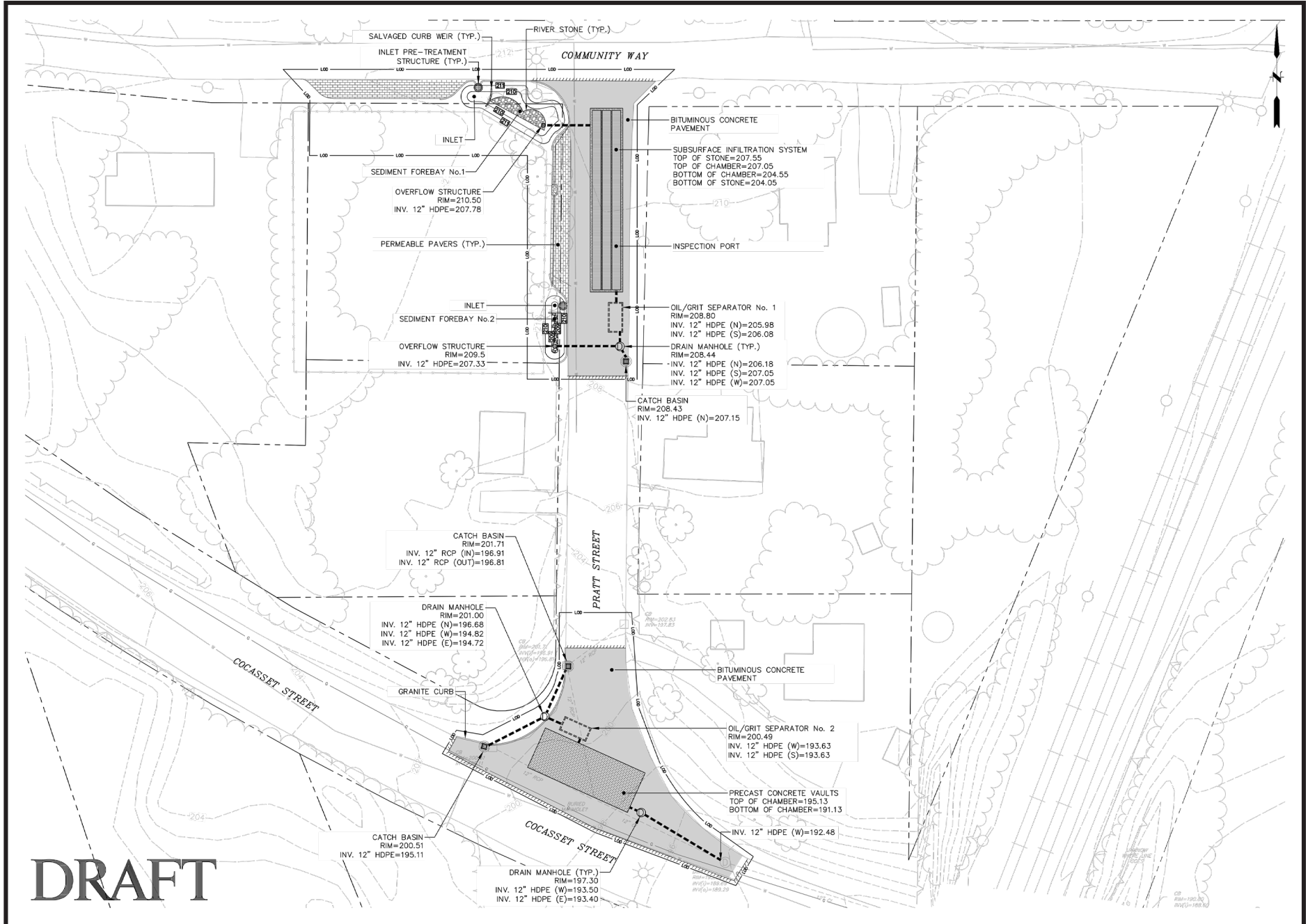

**DRAFT**

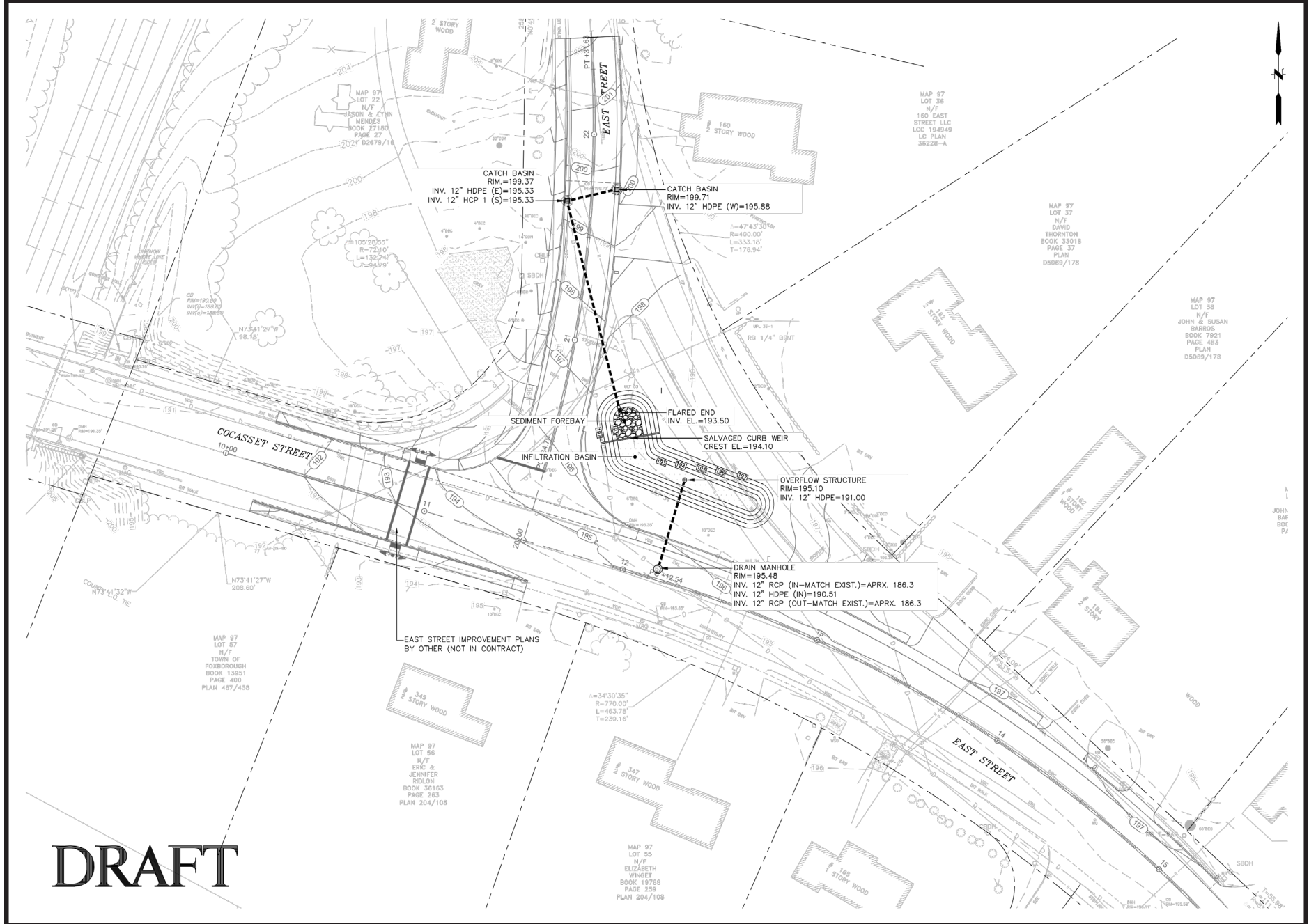

**DRAFT**

## Site Description

The Cocasset Street underpass, located near East Street and the Canoe River, regularly floods even during relatively minor rain events. The underpass is a local low point, receiving runoff from Cocasset Street, East Street, and Pratt Street. A nearby constructed berm exacerbates flooding during larger events. Land use in the area is primarily residential, with the exception of the Ella. G. Hill Playground on Pratt Street. Soil test pits were excavated at the site to investigate local conditions. Test pits showed adequate depth to seasonal high groundwater and soils suitable for infiltration-based GI practices. Additional details on the site and the proposed green infrastructure concept can be found in the Cocasset Street Rail Underpass Design memorandum developed separately under this MVP Action Grant.

## Proposed Green Infrastructure Concept:

1. At the Ella G. Hill Playground, formalize the existing compacted gravel parking with permeable pavers or pavement. Use a curb cut to direct stormwater into sediment forebays to remove sediment and debris. Convey stormwater from the forebay to an oil/grit separator and subsurface infiltration chambers.
2. At the intersection of Pratt & Cocasset Street, divert stormwater from the existing catch basins to subsurface infiltration chambers under the intersection. Use a pre-treatment chamber to remove sediment and floatables prior to infiltration.
3. As part of the roadway realignment and repaving at the intersection of East Street and Cocasset Street, construct a surface infiltration basin in the space opened by the realignment. Replace the existing catch basin on East Street with a pair of catch basins and divert flow into a surface infiltration basin. Additional pavement removal is proposed as part of the intersection realignment.

### Site Data

Impervious Area Treated: 2.65 acres  
Design Storage Volume: 6,827 ft<sup>3</sup>  
Runoff Capture Depth: 1.5 inches

#### Pollutant Removal:

Total Suspended Solids	Phosphorus	Nitrogen	Bacteria
100	99	100	98

Estimated Cost: \$560,000, does not include cost of surface infiltration basin



## 4.3 Other GI Ideas

While this Green Infrastructure Plan makes recommendations for nine publicly owned locations, public input gathered during outreach efforts and discussion with Town staff noted several other privately owned locations with known issues stemming from stormwater. The desktop review of available information also identified several other opportunities on Town-owned properties, and additional municipal-private and municipal-state partnership opportunities that can provide additional climate resilience and water quality benefits. While these benefits can be substantial, they may require additional time and effort to conduct outreach with property owners and could incur additional costs to acquire easements.

Other Town-owned locations would benefit from additional study to identify more substantive recommendations with additional input from the Town, such as the Department of Public Works complex, which regularly experiences flooding. The Town Engineer suggested conducting a facility and drainage study to identify ways the site could be redesigned to better address stormwater generation while making operations more efficient.

Examples of non-municipal locations include state-owned sites, such as the Commercial Street segment of Route 140. Private institutional sites include the Foxborough Regional Charter School and the Sage School, as well as multiple churches in Foxborough, which occasionally have large parking areas. Private commercial locations, such as Schneider Electric and many retail developments around Foxborough offer additional GSI retrofit opportunities.



## 4.4 Typical Details

### Subsurface Infiltration System

Payson Road Athletic Complex - South Parking Lot

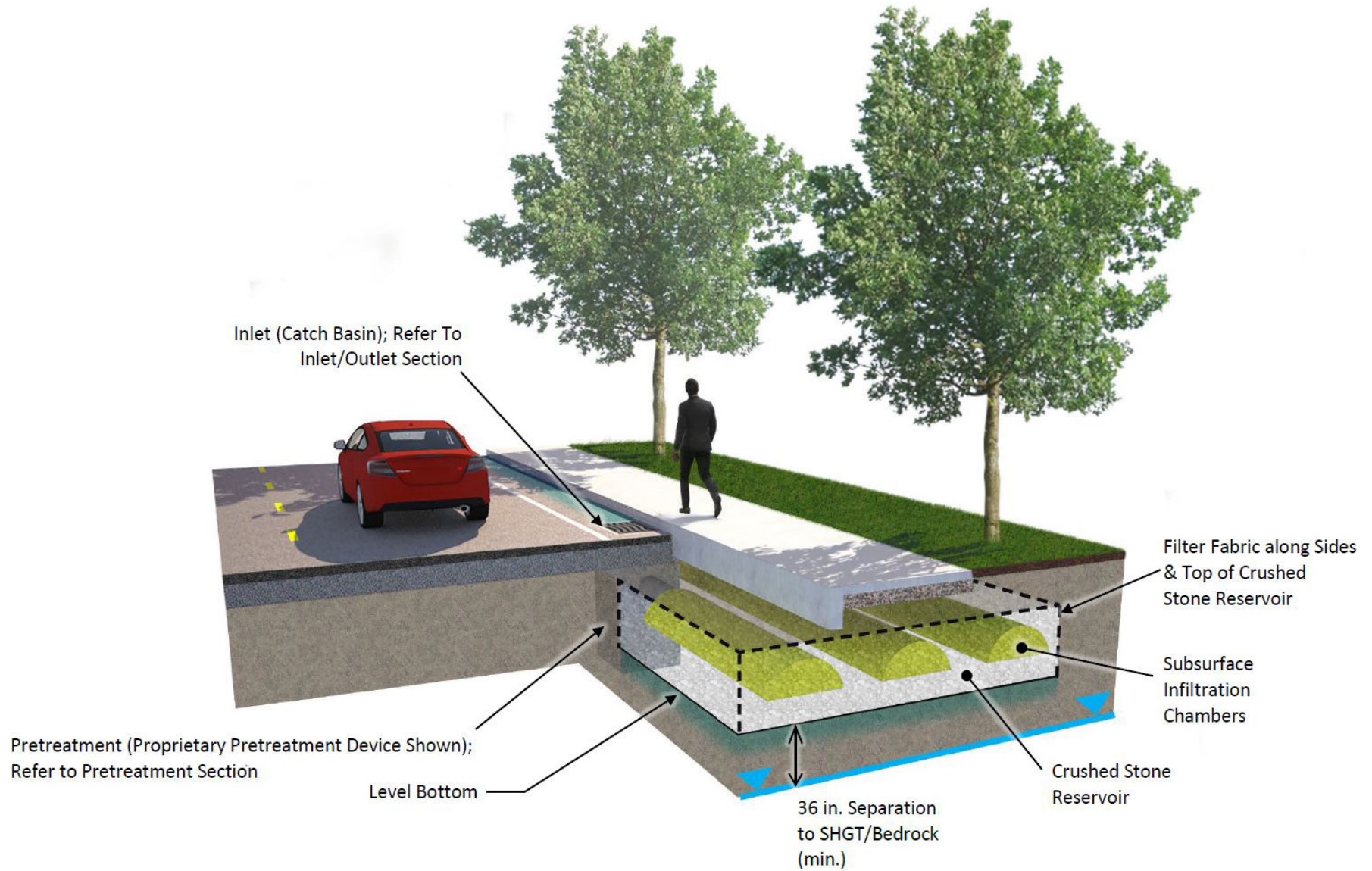

# Infiltration Basin

Payson Road Athletic Complex - Ernie George Field

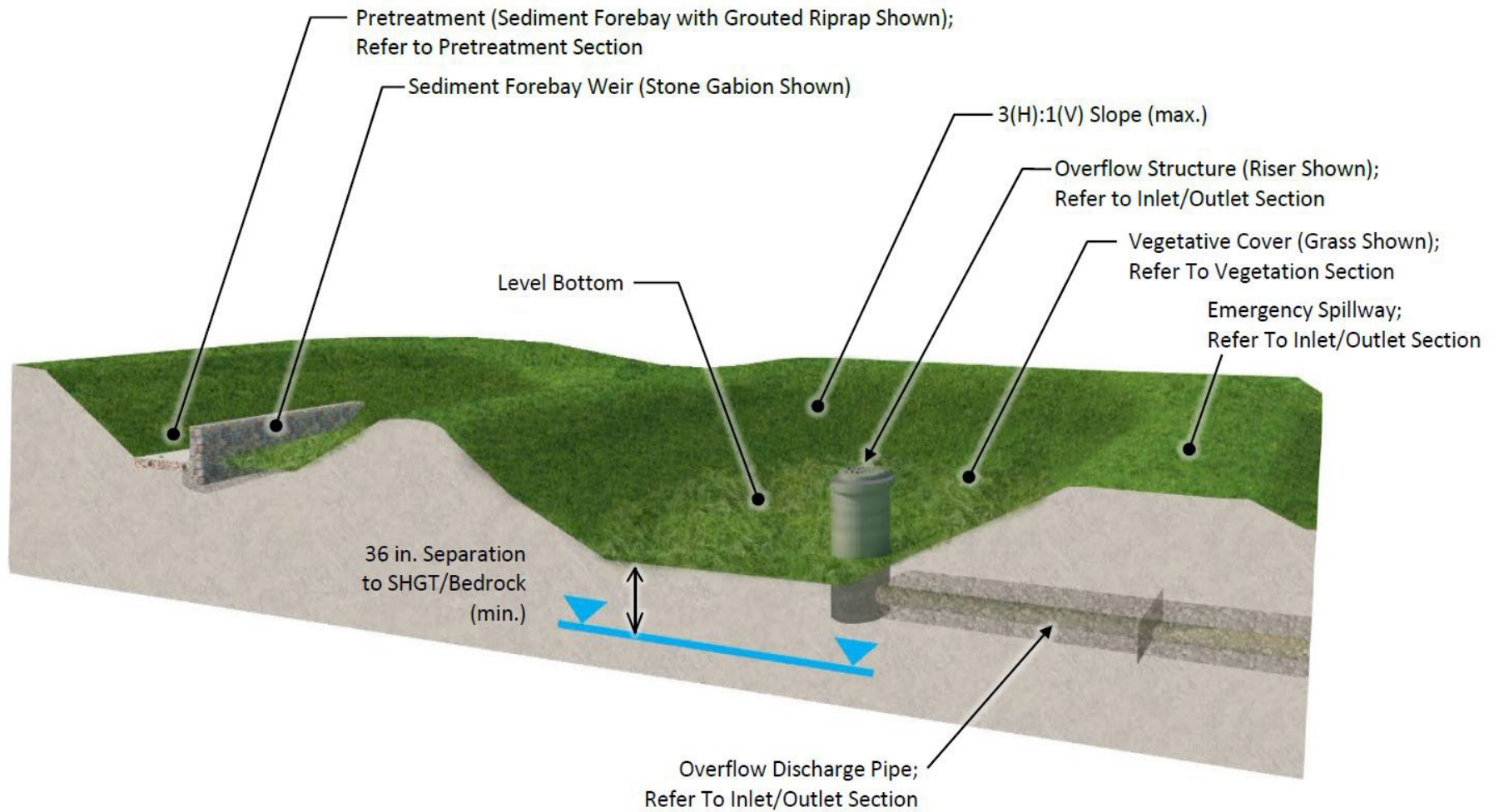



# Parking ROW Infiltration/Bioretention Curb Inlet Planter

Payson Road Athletic Complex - North Parking Lot

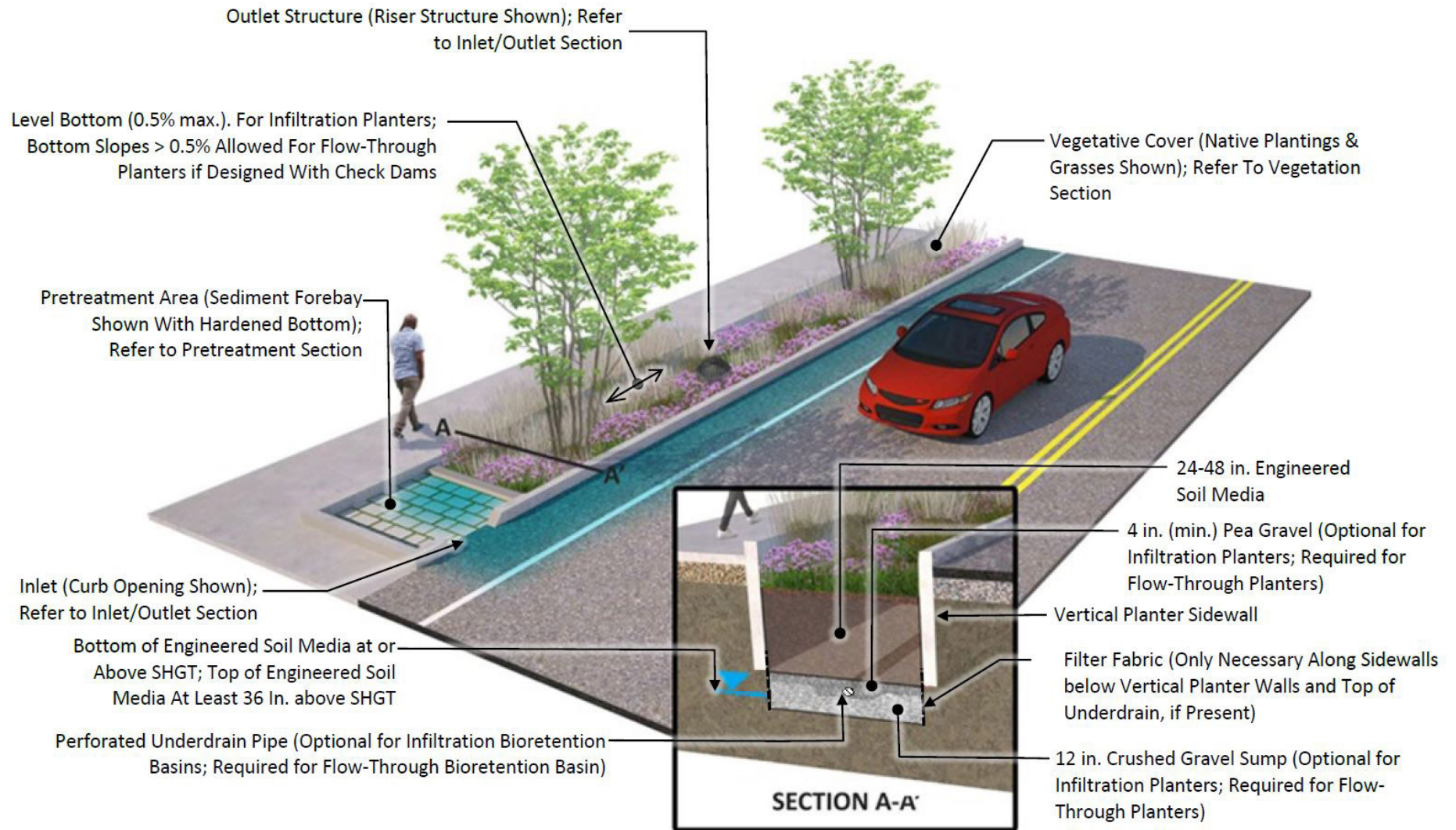

# Bioretention Basin/Swale

Kersey Point Conservation Area  
Igo Elementary School

Council on Aging  
Lane Homestead Conservation Area

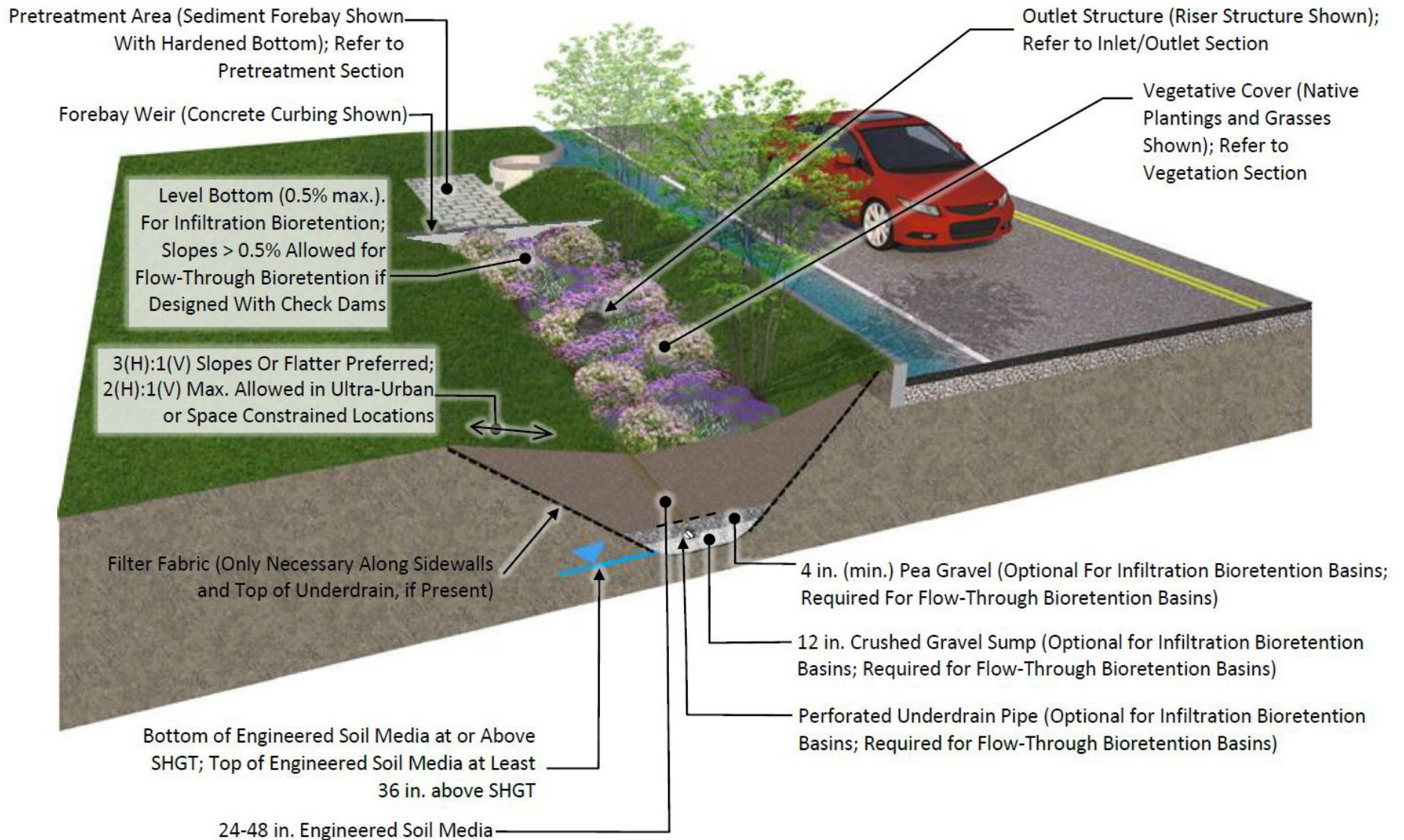



# Dry Well/Leaching Catch Basin

Council on Aging

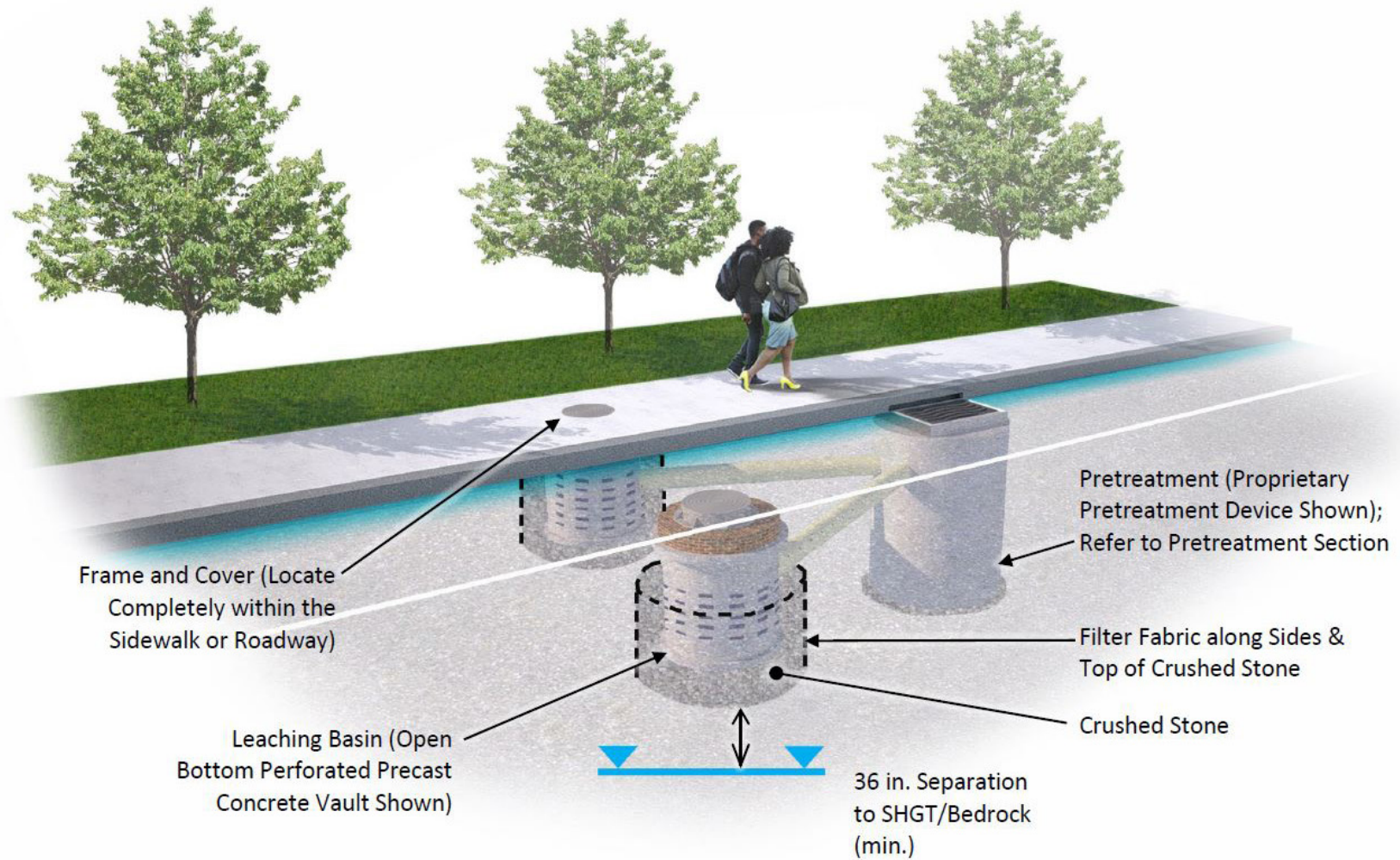



## 5 Funding Sources

When properly designed and maintained, GSI and other nature-based approaches have the benefit of lower maintenance costs and effort over time. Managing stormwater through on-site infiltration reduces the need to dig up, repair, or extend pipe networks. If it becomes necessary over the life of a GSI installation, the infiltration capacity of these practices can be 'refreshed' by replacing media and plantings without major construction effort. A shift toward GSI thus promotes resilience benefits at lower future cost and is a smart long-term investment for the Town. However, like any construction improvement, the initial investment in GSI can be costly.

Fortunately, as climate resilience and nature-based solutions continue to gain traction throughout Massachusetts and the wider United States, a variety of funding programs have become available to fund GSI and other resilience solutions. The Commonwealth of Massachusetts has been at the forefront of prioritizing climate adaptation actions through an expanding set of funding opportunities, and both state and federal opportunities exist to help fund GSI projects. Foxborough anticipates pursuing an array of grant funding to help offset capital costs as the Town gradually begins to incorporate GSI into its future capital projects.

### 5.1 State Funding Sources

#### Executive Office of Energy and Environmental Affairs Planning Assistance Grants

EEA Planning Assistance grants are available to support projects that are consistent with state priorities for land conservation, reduction of natural resource consumption, and climate mitigation and resilience building. Actions implementing the results of climate vulnerability assessments or priorities identified during a community's MVP process are eligible for funding, as are Low Impact Development, and other related projects. Up to \$50,000 is available per municipality, with the option of pursuing a multi-jurisdictional regional project. Projects must include a minimum non-state match of 25%. Approximately \$1M to \$1.3M has been awarded each year.

**Website:**

<https://www.mass.gov/service-details/planning-assistance-grants>

#### Chapter 90 Program

The Chapter 90 program is administered by the Massachusetts Department of Transportation. The program provides 100% reimbursement for approved roadway projects, including projects such as road resurfacing, roadside drainage structures, bridges,

side road approaches, and landscaping and tree planting.

**Website:**

<https://www.mass.gov/chapter-90-program>

#### Clean Water Act, Section 319 Nonpoint Source Implementation Grants

Section 319 Grants are available for projects that promote restoration and protection of water quality through reducing and managing nonpoint source pollution. These grants are made possible by federal funds provided to MassDEP by the USEPA under Section 319 of the Clean Water Act. Eligible applicants include municipal, state, or regional governments, quasi-state agencies, public schools and universities, and non-profit watershed, environmental, or conservation organizations. Pursuant to federal guidelines for Section 319 funding, projects can only be funded in those areas in which a Watershed-Based Plan has been completed. MassDEP created the Massachusetts Watershed-Based Plan (WBP) for all watersheds in the state that can be used to develop proposals for 319 grants.

Clean Water Act Section 319 grants may be used for green stormwater infrastructure projects (if not mandated by a stormwater permit) and certain



restoration activities such as dam removal. The EPA's guidance, "Nonpoint Source Program and Grants Guidelines for States and Territories," includes hydrologic modification as a type of nonpoint source pollution and therefore projects that address hydrologic modification such as dam removal are potentially eligible for funding. Dam removal or river restoration projects need to be consistent with a state's written Nonpoint Source Management Program Plan. Dam removal projects that are included in local watershed-based plans that are consistent with EPA Guidelines would also be eligible for 319 funds.

**MassDEP WBP Website: [https:](https://www.mass.gov/guides/watershed-based-plan-information)**

<https://www.mass.gov/guides/watershed-based-plan-information>

**MassDEP 319 Website:**

<https://www.mass.gov/info-details/grants-financial-assistance-watersheds-water-quality>

### **Division of Ecological Restoration (DER) Project Grants**

The DER offers small grants to fund wetland, river, and flow restoration projects that are high-priority and provide significant ecological and community benefits to the Commonwealth. The DER considers funding for several types of "priority projects," including dam removal and culvert replacements. In addition to small grants, eligible projects also receive technical services (data collection, engineering, design work, and permitting) and project management and fundraising help.

**DER Website: [https:](https://www.mass.gov/how-to/become-a-der-priority-project)**

<https://www.mass.gov/how-to/become-a-der-priority-project>

**Dam Removal Website:**

<https://www.mass.gov/river-restoration-dam-removal>

**Culvert Replacement Website:**

<https://www.mass.gov/river-restoration-culvert-replacements>

### **MassWorks Infrastructure Program**

The MassWorks Infrastructure Program is administered by the Executive Office of Housing and Economic Development, the Department of Transportation, and the Executive Office for Administration and Finance. The program provides

public infrastructure funding to support sustainability in Massachusetts, as well as job creation and economic development. Although the program is not specifically for hazard mitigation, the infrastructure improvements covered under MassWorks could help protect communities from natural disasters such as flooding.

**Website:**

<https://www.mass.gov/service-details/massworks-infrastructure-grants>

### **Municipal Vulnerability Preparedness (MVP) Action Grant Program**

The MVP Action Grant Program is administered through the Executive Office of Energy and Environmental Affairs. To be eligible for funding, communities must complete the MVP Planning Grant process. The MVP Action Grant offers financial assistance to municipalities that are interested in implementing climate adaptation actions to address the impacts of climate change (extreme weather, sea level rise, inland and coastal flooding, severe heat, etc.). The program funds projects relating to planning, assessments, and regulatory updates; nature-based solutions for ecological and public health; and resilient redesigns and retrofits for critical facilities and infrastructure. The MVP program also emphasizes robust engagement of the public and benefits for environmental justice communities or climate vulnerable populations. In past funding rounds, applicants were able to request \$25,000 to \$2,000,000 in funding (up to \$5,000,000 available for regional projects). A 25% match, either through cash or in-kind services, is required.

**Website:**

<https://www.mass.gov/service-details/mvp-action-grant>

### **State Revolving Fund (SRF) Loan Program**

The SRF provides a low-cost financing option for communities through two programs: the Clean Water Program and the Drinking Water Program. The Clean Water Program provides loans to help municipalities comply with federal and state water quality requirements by focusing on watershed management priorities, stormwater management, and GSI. The Drinking Water SRF Program provides loans to communities to improve water supply infrastructure and drinking water safety.

**SRF Clean Water Program Website:**

<https://www.mass.gov/service-details/srf-clean-water-program>

**SRF Drinking Water Program Website:**

<https://www.mass.gov/service-details/srf-drinking-water-program>

**Water Management Act (WMA) Grant Program**

The WMA grant program is available to WMA permit holders. The program provides aid for planning assistance, demand management, and withdrawal impact mitigation projects in local communities. Grants are reimbursed at 80% and require a 20% match through in-kind services or cash. The Commonwealth awards approximately 10 grants per year. Both planning and implementation projects are eligible.

**Website:**

<https://www.mass.gov/info-details/water-management-act-grant-programs-for-public-water-suppliers>

## 5.2 Federal Funding Sources

**Army Corps of Engineers Aquatic Ecosystem Restoration Program**

Under Section 206 of the Water Resources Development Act of 1996 (33 U.S.C. 2330), the Army Corps of Engineers can participate in the study, design and implementation of ecosystem restoration projects. Projects conducted in New England under this program have included eelgrass restoration, salt marsh and salt pond restoration, freshwater wetland restoration, anadromous fish passage and dam removal, river restoration, and nesting bird island restoration. Projects must be in the public interest and cost effective and are limited to \$10 million in Federal cost. Non-Federal project sponsors must be public agencies or national non-profit organizations capable of undertaking future requirements for operation, maintenance, repair, replacement and rehabilitation (OMRR&R), or may be any non-profit organization if there are no future requirements for OMRR&R. The Corps of Engineers provides the first \$100,000 of study costs. A non-Federal sponsor must contribute 50 percent of the cost of the feasibility study after the first \$100,000 of expenditures, 35 percent of the cost of design and construction, and 100 percent of operation and maintenance costs.

**Website:**

<http://www.nae.usace.army.mil/Missions/Public-Services/Continuing-Authorities-Program/Section-206/>

**Community Rating System (CRS) under National Flood Insurance Program (NFIP)**

The Community Rating System is a voluntary program under the NFIP that encourages municipalities to participate in flood management activities that exceed the minimum requirements of the NFIP. There are three goals of the CRS: reduce flood damage to insurable property, strengthen and support the insurance aspects of the NFIP, and encourage a comprehensive approach to floodplain management. Communities participating in the CRS receive reduced insurance premiums as a result of their compliance.

**Website:**

<https://www.fema.gov/media-library/assets/documents/181241>

## FEMA Hazard Mitigation Assistance Grant Programs

The Federal Emergency Management Agency (FEMA) administers two major programs related to hazard mitigation: the National Flood Insurance Program (see Section 3.1 of this plan) and the Hazard Mitigation Assistance Program. FEMA's hazard mitigation assistance grant programs provide funding to protect life and property from future natural disasters. In Massachusetts, these programs are administered by the Massachusetts Emergency Management Agency (MEMA). FEMA flood hazard mitigation assistance funding is available to Massachusetts communities through the following programs:

- **Building Resilient Infrastructure and Communities (BRIC)** BRIC provides funds to support public infrastructure projects that increase a community's resiliency to reduce the effects of future disasters. The program replaced the former Pre-Disaster Mitigation (PDM) program in 2020. The goal of the BRIC program is to reduce overall risk to the population and structures, while at the same time, also reducing reliance on Federal funding from actual disaster declarations. A 25% non-federal share (local government or other organization) is required.
- **Flood Mitigation Assistance (FMA)** provides funds for projects to reduce or eliminate risk of flood damage to buildings that are insured under the National Flood Insurance Program (NFIP) on an annual basis. These are cost share grants for pre-disaster planning and projects, with a federal share (up to 100%) and non-federal share (local government or other organization).
- **Severe Repetitive Loss (SRL)** is designed to reduce flood damages to residential properties that have experienced SRLs under flood insurance coverage. The program provides funds so that measures can be taken to reduce or eliminate risk of flood damage to buildings insured under the NFIP. Funding is available on an annual basis (as available). SRL provides up to 90% Federal funding for eligible projects.
- **Hazard Mitigation Grant Program (HMGP)** assists in implementing long-term hazard mitigation measures following Presidential disaster declarations. Funding is available to

implement plans or projects in accordance with State, Tribal, and local priorities. HMGP grants are post-disaster cost share grants consisting of 75% federal share and 25% non-federal share (local government or other organization).

- **Public Assistance (PA) Grants** provide assistance to local, tribal and state governments and certain types of Private Non-Profit (PNP) organizations so that communities can quickly respond to and recover from major disasters or emergencies declared by the President. Through the PA Program, supplemental Federal disaster grant assistance is provided for debris removal, emergency protective measures, and the repair, replacement, or restoration of disaster-damaged, publicly owned facilities and the facilities of certain PNP organizations. The PA Program also encourages protection of these damaged facilities from future events by providing assistance for hazard mitigation measures during the recovery process.

### Website:

<https://www.fema.gov/hazard-mitigation-assistance>

## National Fish and Wildlife Foundation (NFWF) New England Forests and Rivers Fund

The National Fish and Wildlife Foundation (NFWF) New England Forests and Rivers Fund is dedicated to restoring and sustaining healthy forests and rivers that provide habitat for diverse native bird and freshwater fish populations in the six New England states. This program annually awards competitive grants ranging from \$50,000 to \$200,000 each. Since its creation in 2015, the Fund has awarded 48 grants to restore early successional habitat, modify and replace barriers to fish movement, restore riparian and instream habitat, and engage volunteers in forest habitat restoration and stream connectivity projects. Major funding for the New England Forests and Rivers Fund is provided by Eversource Energy, the U.S. Fish and Wildlife Service, and the U.S. Department of Agriculture's Natural Resources Conservation Service and Forest Service.

### Website:

<http://www.nfwf.org/newengland/Pages/home.aspx>

## US Department of Housing and Urban Development (HUD) Community Development Block Grants

Title 1 of the Housing and Community Development Act of 1974 authorized the Community Development Block Grant program. The program is sponsored by the US Department of Housing and Urban Development. The Massachusetts program is administered through the Massachusetts Department of Housing and Community Development. CDBG-DR (disaster recovery) funds may be used to restore public facilities and infrastructure, rehabilitate or replace housing, acquire property, promote economic revitalization, and support Hazard Mitigation Planning. CDBG-DR funds are intended to support long-term recovery from a specific natural disaster and may not be applied to recovery activities associated with other disasters. Annual CDBG Program funds may also be used for certain eligible hazard mitigation and disaster recovery activities (Commonwealth of Massachusetts, n.d.). Implementation of green stormwater infrastructure and drainage system upgrades to mitigate drainage-related flooding is potentially eligible for CDBG funding.

### Website:

<https://www.mass.gov/service-details/community-development-block-grant-cdbg>

## US Department of Agriculture (USDA) Natural Resources Conservation Service (NRCS) Funding Programs

The USDA Natural Resources Conservation Service (NRCS) works with land owners in Massachusetts to improve and protect soil, water, and other natural resources. NRCS has several funding programs in Massachusetts that help property owners address flooding and water quality issues.

- **The Emergency Watershed Protection (EWP) Program** is designed to help people and conserve natural resources by relieving imminent hazards to life and property caused by floods, fires, windstorms, and other natural occurrences. EWP is an emergency recovery program, which responds to emergencies created by natural disasters. It is not necessary for a national emergency to be declared for an area to be eligible for assistance. EWP is designed for installation of recovery measures.

Activities include providing financial and technical assistance to remove debris from stream channels, road culverts, and bridges, reshape and protect eroded banks, correct damaged drainage facilities, establish cover on critically eroding lands, repair levees and structures, and repair conservation practices.

### Website:

<https://www.nrcs.usda.gov/wps/portal/nrcs/main/national/programs/landscape/ewpp/>

- **The Emergency Watershed Protection - Floodplain Easement Program (EWP-FPE)** provides an alternative measure to traditional EWP recovery, where it is determined that acquiring an easement in lieu of recovery measures is the more economical and prudent approach to reducing a threat to life or property. The easement area is restored to the maximum extent practicable to its natural condition using structural and nonstructural practices to restore the flood storage and flow, erosion control, and improve the practical management of the easement. Floodplain easements restore, protect, maintain and enhance the functions of floodplains while conserving their natural values such as fish and wildlife habitat, water quality, flood water retention and ground water recharge. Structures, including buildings, within the floodplain easement must be demolished and removed, or relocated outside the 100-year floodplain or dam breach inundation area.

### Website:

<https://www.nrcs.usda.gov/wps/portal/nrcs/detail/ct/programs/financial/ewp/?cid=stelprdb1244478>

- **The Watershed and Flood Prevention Operations Program** provides technical and financial assistance to states, local governments and Tribes to plan and implement watershed project plans for the purpose of watershed protection, flood mitigation, water quality improvement, fish and wildlife enhancement, wetlands and wetland function creation and restoration, groundwater recharge, and wetland and floodplain conservation easements.

### Website:

<https://www.nrcs.usda.gov/wps/portal/nrcs/main/national/programs/landscape/wfpo/>

## American Rescue Plan Act

In 2021, Congress passed and President Biden signed the American Rescue Plan Act, which includes \$1.9 trillion dollars in funding to individuals, schools, businesses, and areas suffering from the COVID-19 pandemic. \$130 billion is directed to municipal and county governments for the purpose of replacing revenue lost or reduced due to the pandemic, funding COVID-related costs, providing support to aid households and businesses impacted by the crisis investing in economic recovery and renewal, and funding investments in water, sewer and broadband infrastructure. GSI and stormwater projects can be funded under the sewer infrastructure category. As of June 1, 2021, Foxborough's total allocation through ARPA was anticipated to be approximately \$1.9 million. In addition, Norfolk County has also received \$137 million to use in its constituent communities. The funds will be provided in two blocks, in 2021 and 2022, and will be available for use through 2024.







MVP  
Municipal Vulnerability  
Preparedness





**Appendix L**  
**Nutrient Source Identification Report**

# **Nutrient Source Identification Report**

## **Town of Foxborough**

Prepared By: Neponset River Watershed Association  
June 15, 2021

## Acknowledgements

*This is one among twenty Nutrient Source Identification Reports prepared by the Neponset River Watershed Association (NepRWA) and the Pioneer Valley Planning Commission (PVPC). These reports are meant to provide MS4 permitted municipalities with documents they can finalize and submit to U.S. EPA as part of their Year 4 reporting requirements.*

*This work is made possible through a grant from the MassDEP Municipal Assistance Program. Project staff from NepRWA and PVPC appreciate the conversation and feedback provided by MassDEP and U.S. EPA staff in working through methodology to prepare these reports. Aside from producing nutrient source identification reports for 20 communities, this project also resulted in the following: lake-pond phosphorous control plan Year 4 submission requirements for two communities; documentation of approach and methods for use by other MS4 permittees across MA in meeting these Year 4 requirements; and setting of the stage for upgrading existing stormwater infrastructure in key high pollutant loading catchments.*

*NepRWA and PVPC staff are grateful also to the partner communities who joined them in this pilot project. Following is a list of cities and towns who participated in this project:*

<i>Agawam</i>	<i>Medfield</i>	<i>Southampton</i>
<i>Canton</i>	<i>Milton</i>	<i>Southwick</i>
<i>Dedham</i>	<i>Northampton</i>	<i>Stoughton</i>
<i>Foxborough</i>	<i>Quincy</i>	<i>Westfield</i>
<i>Granby</i>	<i>Randolph</i>	<i>Westwood</i>
<i>Longmeadow</i>	<i>Sharon</i>	<i>Wilbraham</i>
<i>Ludlow</i>	<i>South Hadley</i>	

## *Background: The Nutrient Pollution Problem*

Nitrogen and phosphorous are naturally occurring plant fertilizers or “nutrients.” When land is developed, and storm drain systems are installed, the amount of nitrogen and phosphorous discharged to local streams, ponds and wetlands increases significantly relative to natural stream conditions. In the urban environment, nitrogen and phosphorous come from a variety of sources including organic debris such as fallen leaves, animal and pet waste, lawn and agricultural fertilizers, malfunctioning sewers and septic systems, and atmospheric deposition from car exhaust, among other sources.

Some of these sources also occur in the natural environment. However, in the urban environment the prevalence of paved and impervious areas coupled with the availability of storm drain collection systems allows street runoff containing excess nutrient pollution to be very quickly collected and conveyed to the nearest waterbody, generally with little or no treatment—bypassing the natural processes such as soil filtration and infiltration that would capture and recycle nutrients before they reached waterways in an undeveloped landscape.

As a result, nutrient pollution from polluted stormwater runoff has become a major source of pollution across the country. Nutrient pollution increases undesirable plant and algae growth in waterways, which can be highly toxic to humans and wildlife and reduce oxygen levels in the water. This, in turn, impedes recreation and creates chronic challenges for aquatic life, sometimes leading to fish kills. In freshwater waterways phosphorous is generally the primary pollutant of concern, while nitrogen becomes the primary concern once freshwater rivers flow into saltwater estuaries and bays.

## *Background: Regulatory Context*

Under the federal and state clean water acts, the Massachusetts Department of Environmental Protection (MassDEP) is charged with establishing water quality standards and determining whether waterways meet these designated standards. MassDEP publishes its Integrated List of Waters, also referred to as the 303d Impaired Waters List, identifying waters that do not meet standards. These waterways are referred to as being “impaired” or “water quality limited” based on one or more causes which may include nitrogen, phosphorous, “nutrient/eutrophication biological indicators” or in some cases turbidity or transparency. MassDEP is also charged with preparing waterbody-specific cleanup plans for nutrient pollution known as Total Maximum Daily Loads or TMDLs, though these are yet to be prepared for many impaired waterways.

The Town of Foxborough (“the Town”) is subject to the requirements of US Environmental Protection Agency’s (EPA’s) 2016 Massachusetts Small MS4 General Permit. One of the requirements of this permit is that communities discharging stormwater to waterways that are listed by MassDEP as impaired for phosphorous or nitrogen, or that flow into impaired waterways, and for which a total maximum daily load does not exist, shall prepare a Nutrient Source Identification Report as detailed in Appendix H of the permit. This report has been developed to satisfy this requirement of the permit.

The nutrient source identification report must be submitted with the permit year 4 annual report (year ending June 30, 2022 and report due late September 2022). The requirements include (excerpt from EPA 2016 MS4 Permit Appendix H):

1. Calculation of total MS4 area draining to the water quality limited water segments or their tributaries, incorporating updated mapping of the MS4 and catchment delineations produced pursuant to part 2.3.4.6;
2. All screening and monitoring results pursuant to part 2.3.4.7.b., targeting the receiving water segment(s);
3. Impervious area and DCIA for the target catchment;
4. Identification, delineation and prioritization of potential catchments with high [*nitrogen and/or phosphorous*] loading;
5. Identification of potential retrofit opportunities or opportunities for the installation of structural BMPs during redevelopment.

### *MS4 Permit Appendix H Applicability*

Portions of the Town lie both within the Neponset River Watershed and the Taunton River Watershed. Additionally, as mapped in GIS, a very small section of the Town is located in the Charles River Watershed, but there are no catchments in that area and the area (less than 20 acres) was deemed small enough that it is not included in this report. Of the 9 receiving waters identified on the Town's Notice of Intent, one has been identified as specifically impaired for phosphorus. In some cases, the Town's receiving waters also flow into another water body that is impaired for phosphorous, or waters that are listed as impaired for a cause in which phosphorous pollution is a factor such as dissolved oxygen, or eutrophication biological indicators.

The saltwater portion of the Neponset River, known as the Neponset River Estuary, is not specifically listed as impaired for nitrogen by MassDEP, but is listed as impaired for several other factors for which nitrogen pollution is a contributing factor. Furthermore, EPA has directed the City of Quincy to prepare a nutrient source identification report for nitrogen based on its stormwater discharges to the Neponset River. While EPA has not provided any clear direction to other communities in the Neponset River Watershed that are upstream of the Neponset Estuary regarding the need for a nitrogen source identification report, the possibility exists that EPA may issue such a requirement in the future. In the interest of efficiency of analysis, this report also includes an analysis of nitrogen pollution loading for all communities in the Neponset River Watershed. Further, catchments in the Taunton River Watershed are subject to the Mount Hope Bay TMDL.

Therefore, this report has been prepared in accordance with the guidelines in sections I.1.b and II.1.b of Appendix H of the 2016 Massachusetts Small MS4 General Permit.

The status of receiving waters in the Town is summarized in Table 1 below.



Table 1. Receiving Waters for the Town of Foxborough

Receiving Water	Number of Outfalls	Impaired for P?	Impaired for N?	Other Impairments
Neponset River (MA73-01)	21	Yes	No	Dissolved Oxygen, TSS, E. Coli, DDT, PCB, Sedimentation, Excess Algal Growth, Other
Rumford River (MA62-39)	32	No	No	Aquatic Macroinvertebrate Bioassessments, Dioxin, Fecal Coliform, PCP, Sedimentation, Fishes Bioassessment, Physical Habitat Substrate Alteration
Canoe River (MA62-27)	24	No	No	
Wading River (MA62-47)	45	No	No	Dissolved Oxygen, Fecal Coliform
Carpenter Pond (MA62032)	2	No	No	
Neponset Reservoir (MA73034)	21	No	No	TSS, Excess Algae Growth, Non-Native Aquatic Plants
Robinson Brook (MA62-14)	36	No	No	Aquatic Macroinvertebrate Bioassessments, Physical Habitat Substrate Alteration
Mirimichi (MA62118)	1	No	No	Non-Native Aquatic Plants
Plane St. Pond (MA52032)	3	No	No	Excess Algal Growth, Non-Native Aquatic Plants

## Data Sources and Analytical Methods

Several existing datasets were used to complete this work. Table 2 below lists the utilized datasets and their origin.

Table 2. Data Sources

Existing Data Set	Origin	Date Published/Updated	Link
2016 Land Cover/Land Use	MassGIS	May 2019	<a href="https://docs.digital.mass.gov/dataset/massgis-data-2016-land-coverland-use">https://docs.digital.mass.gov/dataset/massgis-data-2016-land-coverland-use</a>
Soil Survey Geographic (SSURGO) Database for Norfolk and Suffolk Counties, Massachusetts	USDA	June 2020	Downloaded through Web Soil Survey ( <a href="https://websoilsurvey.sc.egov.usda.gov/App/HomePage.htm">https://websoilsurvey.sc.egov.usda.gov/App/HomePage.htm</a> ).  Hydrologic soil groups extracted using Soil Data Viewer Version 6.1 ( <a href="https://www.nrcs.usda.gov/">https://www.nrcs.usda.gov/</a> )

			<a href="https://portal/nrcs/detail/soils/survey/geo/?cid=nrcs142p2053619">wps/portal/nrcs/detail/soils/survey/geo/?cid = nrcs142p2053619)</a>
<b>Town Catchments</b>	Town GIS Files	Current as of the publishing of this report	N/A
<b>Massachusetts Land Parcel Database (Metro Boston Region)</b>	MAPC	May 2019	Used to locate SCM opportunities, this shapefile contains the “Parloc_ID” field used to identify parcels.  <a href="https://datacommon.mapc.org/browser/datasets/360">https://datacommon.mapc.org/browser/datasets/360</a>

Impervious area is the portion of the Town that is paved, covered by buildings, or otherwise rendered unable to absorb water naturally due to development. Impervious area for the town was calculated using the MassGIS 2016 Land Cover/Land Use data layer which was published in 2019. This data layer maps impervious and pervious land cover by land use type based on aerial photography and other data sources. This was overlaid with the Town’s data layer for outfall catchment areas (the area draining to each town-owned stormwater discharge point) to estimate total areas and total impervious area discharging to or upstream of nutrient-impaired waterways, as well as to estimate impervious area for each stormwater outfall catchment.

Directly connected impervious area (DCIA), also referred to as “effective impervious cover,” is the amount of impervious area that is directly connected to the storm drain system. Most land in the Town was developed before the creation of modern requirements to capture, clean, slow down, and recharge stormwater runoff using stormwater control measures (SCMs). However, many new development and redevelopment projects constructed in recent years have required the installation or upgrade of SCMs, such that today some properties have no SCMs, some have SCMs that meet some modern standards, and some have SCMs that are fully compliant with modern standards. Because site-specific information about the existence of specific SCMs is not available at the parcel level, an estimate of DCIA or effective impervious cover is used to approximate the average level of SCMs installed across the watershed. Estimating DCIA can yield a more specific pollutant loading estimate for a given area. DCIA was estimated based on land use categories following EPA guidance.

To estimate the pollutant loads for nitrogen and/or phosphorous in each catchment, estimated pollutant loading rates for different combinations of land use type, land cover type, and soil type were applied in accordance with guidance in the EPA 2016 MS4 Permit. The individual loading rates for these unique subsections were summed based on catchment, which produced an overall estimated catchment pollutant loading rate.

For a more detailed description of the analytical methods used for this project, please refer to the supplement to this report, entitled “Nutrient Source Identification Report Addendum: Methods.”

Note that one catchment in the Town’s data set identified as “N/A” was a multipart shapefile made up of several catchments spread throughout the Town. This was assumed to be a collective entry for catchments with no definitive outfall. While this catchment was included in analysis, it was removed from any rankings.

### *Total Area Draining to Water Quality Limited Segments (or Tributaries)*

The total area of the Town is approximately 13,314 acres. Since all areas of the Town are located either in the Neponset River Watershed or the Taunton River Watershed and drainage flows either directly to waters that are impaired for phosphorus or waters that are listed as impaired for a cause in which phosphorous pollution is a factor, this report included all areas of the town in the evaluation. Table 3 below shows how much of the Town is located in each watershed.

Similarly, portions of the town are upstream of the Neponset Estuary and therefore drain to a segment that EPA may consider impaired for nitrogen. While EPA has not provided clear guidance indicating that the Town is subject to the requirements of Appendix H of the 2016 MS4 permit for nitrogen, this report includes the analysis for nitrogen so that the relevant data is available should EPA make such a determination in the future. Therefore, catchments located in the Neponset River Watershed were included in the nitrogen loading analysis sections of this report. Catchments located in the Taunton River Watershed are subject to the Mt. Hope Bay TMDL and therefore were also included in catchment rankings for nitrogen.

*Table 3. Summary of Area Draining to Water Quality Limited Segments*

<b>Receiving Water Impaired for Phosphorus</b>	<b>Neponset Watershed</b>	<b>Taunton Watershed</b>	<b>Total</b>
<b>Total Area of Town (Acres)</b>	2,686	10,628	13,314
<b>Area Draining to Phosphorous Impaired Waters or Potentially Impaired Waters (Acres)</b>	2,686	10,628	13,314
<b>Area Draining to Nitrogen Impaired or Potentially Impaired Waters (Acres)</b>	2,686	10,628	13,314

### *Impervious Area and Directly Connected Impervious Area*

Table 4 below summarizes the total impervious area (IA) and estimated DCIA in the Town. It is also important to note that most of the impervious area in the Town is not owned or maintained by the Town, but by private parties or other public agencies.

*Table 4. Summary of Impervious Area and DCIA*

	<b>Neponset Watershed</b>	<b>Taunton Watershed</b>	<b>Total</b>
<b>Impervious Area (Acres)</b>	563	1,362	1,925

<b>Estimated DCIA (Acres)</b>	16	29	45
-------------------------------	----	----	----

Table A-1 and A-2 in Appendix A of this report provides impervious area and estimates of DCIA for the Town’s catchments in the Taunton and Neponset River Watersheds, respectively. Table 5 and 6 below show the same information for the ten catchments with the most impervious area in each watershed. The catchments are labeled using the Town’s identifier for the outfall to which they drain. The table is sorted in descending order of total impervious area.

*Table 5. Total Impervious Area and DCIA for the Ten Most Impervious Town Catchments in the Taunton River Watershed*

<b>Catchment Identifier</b>	<b>Impervious Area (Acres)</b>	<b>Percent Impervious</b>	<b>DCIA (Acres)</b>	<b>Percent DCIA</b>
12-08	21.09	57.69 %	4.32	11.81 %
22-100	17.41	23.76 %	1.55	2.12 %
12-103	16.57	50.30 %	2.86	8.68 %
20-07	15.34	29.16 %	2.91	5.53 %
04-100	15.31	64.94 %	6.16	26.12 %
08-11	10.41	21.98 %	1.29	2.73 %
09-02	7.77	24.57 %	1.24	3.93 %
06-13	7.65	30.90 %	2.18	8.80 %
08-15	7.55	43.92 %	1.90	11.04 %
12-09	6.52	52.28 %	1.47	11.80 %
<b>Top 10 Catchments as a % of Town Watershed Total</b>	27.99 %		27.44 %	

*Table 6. Total Impervious Area and DCIA for the Ten Most Impervious Town Catchments in the Neponset River Watershed*

<b>Catchment Identifier</b>	<b>Impervious Area (Acres)</b>	<b>Percent Impervious</b>	<b>DCIA (Acres)</b>	<b>Percent DCIA</b>
08-21	11.04	45.70 %	3.42	14.17 %
02-08	7.20	20.50 %	0.93	2.65 %
02-100	5.12	76.15 %	1.63	24.25 %
012	5.04	83.12 %	3.14	51.78 %
02-09	4.72	22.74 %	0.64	3.10 %
08-03	4.48	16.74 %	0.71	2.67 %
05-02	4.39	28.40 %	0.89	5.76 %
07-100	4.03	21.78 %	0.55	2.96 %
05-11	3.91	21.33 %	0.54	2.97 %
05-12	3.08	22.28 %	0.53	3.81 %
<b>Top 10 Catchments as a % of Town Watershed Total</b>	49.33 %		45.66 %	

## Estimated Nutrient Loading from Catchments

Using the methods described in the addendum to this report, estimates of phosphorus and nitrogen loading potential were created for each of the Town's storm drain outfall catchments.

Tables B-1 and B-2 in Appendix B and C-1 and C-2 in Appendix C of this report show calculated phosphorus and nitrogen loading estimates, respectively, for all catchments in the Town. Tables 7-10 below show the five catchments with the highest estimated phosphorus and nitrogen loading, respectively.

Table 7. Estimated Phosphorus Loading for Five Highest-Load Town Catchments in the Taunton River Watershed

Catchment Identifier	Estimated P Load (Lbs/Yr)
22-100	45.20
12-08	42.04
20-07	34.59
12-103	33.02
04-100	28.21
<b>Top 5 as a % of Total Town Watershed Load</b>	18.34 %

Table 8. Estimated Nitrogen Loading for Five Highest-Load Town Catchments in the Taunton River Watershed

Catchment Identifier	Estimated N Load (Lbs/Yr)
22-100	387.13
12-08	327.45
20-07	285.56
12-103	266.65
04-100	224.90
<b>Top 5 as a % of Total Town Watershed Load</b>	18.32 %

Table 9. Estimated Phosphorus Loading for Five Highest-Load Town Catchments in the Neponset River Watershed

Catchment Identifier	Estimated P Load (Lbs/Yr)
08-21	21.62
02-08	19.54
02-09	13.04
08-03	9.86
02-100	9.49
<b>Top 5 as a % of Total Town Watershed Load</b>	30.58 %

Table 10. Estimated Nitrogen Loading for Five Highest-Load Town Catchments in the Neponset River Watershed

Catchment Identifier	Estimated N Load (Lbs/Yr)
08-21	169.18
02-08	156.13
02-09	108.39
07-04	82.93
02-100	75.78
<b>Top 5 as a % of Total Town Watershed Load</b>	31.05 %

Note these are estimated loadings based on soil type, land use and estimated DCIA (e.g. typical level of SCMs in town). Actual loading may vary considerably from site to site depending on what SCMs are actually present, and regional studies such as the Charles River Phosphorous TMDL have indicated that the default DCIA assumptions used by EPA are somewhat optimistic, such that actual loading rates may be higher. However, these estimates provide a valuable guide to help identify those areas of the Town that should be the highest priorities for interventions to begin reducing pollutant loading.

### *Outfall Screening Monitoring Results*

As of the writing of this report, outfall screening results are not available. Once they become available, they will be discussed in this section and the findings shall be incorporated into the determination of the highest priority catchments with respect to phosphorus and nitrogen loading. When completed, outfall screening data will be added to Appendix F of this report.

### *Catchment Prioritization*

Since no outfall screening data are currently available to improve projections, this report is prioritizing the catchments based solely on the phosphorus and nitrogen loading estimates, in the order shown in Tables B-1 and B-2 (phosphorus) and C-1 and C-2 (nitrogen). When outfall screening data become available, the list of catchments should be re-examined and the “Top 5” list should be updated based on these real-world data.

### *Potential Retrofit Opportunities*

Town parcels were examined for potential BMP retrofit opportunities using the Neponset Stormwater Partnership’s BMP Tool (NSP BMP Tool). This tool analyzes soil data, estimated pollutant loading, and various limitations of each parcel in Town to determine the locations most suitable for further field assessment of SCM opportunities to reduce chosen pollutants.

The NSP BMP Tool uses slightly different methods to estimate pollutant loading than are utilized in this report so estimated loading rates will differ. However, this does not diminish the utility of the NSP BMP Tool as a means to help identify potential retrofit sites, especially given additional features that are incorporated into the Tool.

After assessing the data, each high-loading catchment was reviewed for potential SCM sites. Five parcels were chosen and are listed in Tables 11-14 below. All parcels in these lists are Town-owned, as town-owned properties often present the fewest barriers to SCM development. These sites should be visited first when performing reconnaissance work to locate SCMs that will reduce nutrient loading in the town. Additionally, it should be noted that the NSP BMP Tool does not rank rights-of-way as Town-owned, but they are often highly desirable sites for SCMs. All rights-of-way, particularly in the high-loading catchments, should be considered in addition to individual parcels. Note that “Parloc\_ID” is an attribute from the MAPC parcel data set that may be helpful in identifying the indicated parcels.

More extensive lists of Town-owned properties to be considered for SCM development is included in Appendix D and E. In these lists, they are ranked by the BMP Tool’s priority score, which projects each parcel’s pollutant load and considers how suited that parcel is for SCM’s designed to remove the targeted pollutant. Appendix D ranks parcels for phosphorus removal and Appendix E ranks them for nitrogen removal. The larger lists in these appendices should be considered a more comprehensive collection of the parcels that should be considered first for SCM development. As Town-owned parcels are evaluated, the Town should begin considering privately-owned parcels, as well, using the NSP BMP Tool as a guide.



Table 11. High-Priority Parcels in the Taunton Watershed to be Considered for SCM Development for Phosphorus Pollution

Address	Parloc_ID	Catchment	Notes
<b>46-48 North Grove St</b>	M_219479_864627	19-21	Appears to be a residential parcel, but includes undeveloped land to the rear. May be difficult, but could be made to accept runoff from the neighborhood.
<b>58-60 North Grove St</b>	M_219584_864547	19-21	Appears to be a residential parcel, but includes undeveloped land to the rear. May be difficult, but could be made to accept runoff from the neighborhood.
<b>196 South St</b>	M_220390_866506	010	Charles G. Taylor Elementary School with open spaces throughout.
<b>111 Mechanic St</b>	M_221674_868806	08-17	John J. Ahern Middle School with open spaces throughout.
<b>Bradner St</b>	M_221076_865139	20-26	Undeveloped parcel in residential area.

\*Few highly-rated Town-owned parcels were found in the Taunton River Watershed in prioritized catchments. It is recommended that roadways in the high-load catchments are strongly considered to address phosphorus pollution.

Table 12. High-Priority Parcels in the Taunton Watershed to be Considered for SCM Development for Nitrogen Pollution

Address	Parloc_ID	Catchment	Notes
<b>10 Bird Street</b>	M_220651_868426	12-08	Boydon Library. Not a lot of open space, but scored highly by the NSP BMP Tool.
<b>196 South St</b>	M_220390_866506	010	Charles G. Taylor Elementary School with open spaces throughout.
<b>1-40 Centennial Ct</b>	M_22047_868043	12-103	Multi-family housing area with some green spaces.
<b>40 South St</b>	M_220691_868058	12-103	Foxborough Town Hall. Large parking area with some open green spaces.
<b>Unlisted</b>	M_220524_868267	12-103	Multiple unit building with moderately-sized parking area.

Table 13. High-Priority Parcels in the Neponset River Watershed to be Considered for SCM Development for Phosphorus Pollution

Address	Parloc_ID	Catchment	Notes
<b>Young Rd</b>	M_220234_871577	02-08	Undeveloped parcel in residential area.
<b>Beach St</b>	M_222189_871726	02-09	Undeveloped parcel near residential area.
<b>25 Pumping Station Rd</b>	M_221637_869761	08-03	Large undeveloped parcel near residential area.
<b>8 Chestnut St</b>	M_219985_869475	08-21	Large building with very large parking area and open space on the north side.
<b>66-68 Baker Street</b>	M_220382_869277	08-02	Multi-family housing area with some green spaces.

\*Very few Town-owned parcels were found in the Neponset River Watershed in prioritized catchments. It is recommended that roadways in the high-load catchments are strongly considered to address phosphorus pollution.

Table 14. High-Priority Parcels in the Neponset River Watershed to be Considered for SCM Development for Nitrogen Pollution

Address	Parloc_ID	Catchment	Notes
<b>8 Chestnut St</b>	M_219985_869475	08-21	Large building with very large parking area and open space on the north side.
<b>25 Pumping Station Rd</b>	M_221637_869761	08-03	Large undeveloped parcel near residential area.
<b>Young Rd</b>	M_220234_871577	02-08	Undeveloped parcel in residential area.
<b>Beach St</b>	M_222189_871726	02-09	Undeveloped parcel near residential area.
<b>90 Baker St</b>	M_220516_869194	08-02	Multi-family housing area with some green spaces.

\*Very few Town-owned parcels were found in the Neponset River Watershed in prioritized catchments. It is recommended that roadways in the high-load catchments are strongly considered to address nitrogen pollution.

These results provide a valuable starting point for the next phase of requirements in Appendix H of the 2016 MS4 Permit which are due by the end of permit year 5 (6/30/2023), which include:

- “Evaluate all permittee-owned properties identified as presenting retrofit opportunities”,
- “Provide a listing of planned structural BMPs and a plan and schedule for implementation”, and
- “Any structural BMPs installed...by the permittee...shall be tracked and the permittee shall estimate the phosphorus removal by the BMP.”

## **Appendix A: Impervious/DCIA Summary by Catchment**

Table A-1. Impervious and DCIA Amounts for All Town Catchments in the Taunton River Watershed, Sorted by Impervious Area

Catchment Identifier	Impervious Area (Acres)	Percent Impervious	DCIA (Acres)	Percent DCIA
N/A	102.55	27.13	7.04	1.86
12-08	21.09	57.69	4.32	11.81
22-100	17.41	23.76	1.55	2.12
12-103	16.57	50.30	2.86	8.68
20-07	15.34	29.16	2.91	5.53
04-100	15.31	64.94	6.16	26.12
08-11	10.41	21.98	1.29	2.73
09-02	7.77	24.57	1.24	3.93
06-13	7.65	30.90	2.18	8.80
08-15	7.55	43.92	1.90	11.04
12-09	6.52	52.28	1.47	11.80
17-07	6.04	24.08	1.12	4.47
010	6.04	21.89	0.88	3.20
005	5.98	26.94	1.28	5.79
19-12	5.83	26.44	1.24	5.61
08-01	5.29	25.28	1.05	5.03
04-01	5.12	25.42	1.21	5.99
20-03	4.87	55.81	2.18	24.97
06-02	4.70	22.57	0.68	3.29
13-17	4.53	35.73	1.25	9.85
22-01	4.48	27.67	1.35	8.31
08-17	4.05	28.40	1.57	11.00
18-07	3.61	21.29	0.66	3.90
12-07	3.53	29.29	0.88	7.28
20-26	3.45	13.88	0.36	1.46
014	3.43	37.57	0.84	9.24
09-19	3.36	24.10	0.52	3.69
15-03	2.89	15.28	0.47	2.47
19-03	2.86	19.16	0.37	2.47

16-02	2.77	63.93	1.29	29.90
07-03	2.73	18.11	0.43	2.83
06-07	2.71	22.75	0.73	6.11
14-01	2.70	33.78	0.60	7.46
09-14	2.54	11.98	0.34	1.58
16-13	2.49	19.44	0.41	3.17
19-21	2.43	12.67	0.42	2.21
09-15	2.40	20.09	0.42	3.53
18-08	2.37	31.41	0.60	8.02
20-11	2.30	12.46	0.31	1.70
12-11	2.27	29.72	0.62	8.06
14-13	2.23	45.63	0.80	16.36
001	2.11	17.49	0.25	2.06
09-101	1.91	26.63	0.50	6.95
22-02	1.85	28.97	0.41	6.46
08-100	1.84	48.89	0.99	26.22
09-12	1.84	21.62	0.40	4.75
12-10	1.80	34.53	0.48	9.32
06-10	1.77	18.16	0.23	2.40
016	1.72	30.33	0.47	8.33
20-35	1.67	23.11	0.40	5.58
13-02	1.66	47.64	0.76	21.83
18-03	1.66	29.92	0.41	7.48
08-10	1.65	23.94	0.39	5.62
12-102	1.60	45.47	0.69	19.68
20-32	1.60	32.65	0.46	9.48
19-17	1.59	30.46	0.44	8.37
07-08	1.54	26.89	0.28	4.85
22-10	1.50	35.75	0.31	7.31
09-10	1.45	28.52	0.53	10.37
19-11	1.39	16.51	0.33	3.88
09-22	1.39	60.97	0.85	37.46

008	1.35	26.73	0.31	6.22
20-17	1.34	17.01	0.19	2.36
12-02	1.34	18.01	0.36	4.82
13-18	1.30	15.12	0.19	2.22
19-15	1.28	25.69	0.29	5.75
13-100	1.22	22.42	0.38	6.92
09-20	1.21	29.11	0.32	7.80
17-12	1.17	38.97	0.31	10.29
20-102	1.14	20.44	0.25	4.46
06-01	1.13	31.06	0.27	7.41
20-25	1.13	46.86	0.47	19.58
16-100	1.12	35.19	0.34	10.63
20-27	1.11	16.93	0.23	3.48
11-03	1.09	18.33	0.28	4.72
16-12	1.09	31.00	0.36	10.17
003	1.05	50.52	0.36	17.16
06-03	1.03	21.98	0.21	4.50
22-11	1.01	34.70	0.33	11.44
14-12	0.98	39.51	0.36	14.74
22-05	0.96	13.01	0.14	1.93
12-04	0.96	15.69	0.19	3.04
13-19	0.95	66.29	0.48	33.22
09-21	0.94	55.20	0.61	35.42
11-04	0.91	27.28	0.32	9.63
004	0.90	33.33	0.32	11.90
12-100	0.88	59.22	0.28	18.86
20-34	0.87	26.63	0.23	7.02
06-04	0.86	15.45	0.15	2.71
20-28	0.85	16.54	0.21	4.12
19-16	0.81	15.81	0.12	2.36
20-100	0.80	39.68	0.42	20.78
15-05	0.79	28.89	0.21	7.85



19-01	0.78	36.82	0.24	11.41
10-01	0.78	30.98	0.42	16.61
19-13	0.77	26.95	0.24	8.54
22-03	0.76	18.77	0.20	4.98
18-02	0.76	25.42	0.26	8.73
06-101	0.75	30.96	0.17	7.19
17-09	0.74	17.19	0.13	2.95
16-11	0.73	22.82	0.17	5.18
13-07	0.73	31.67	0.28	12.30
17-04	0.71	15.05	0.17	3.51
14-14	0.71	2.89	0.06	0.24
16-06	0.67	26.57	0.16	6.16
18-101	0.67	40.68	0.31	19.00
14-10	0.66	30.80	0.20	9.32
14-05	0.65	32.66	0.15	7.56
19-02	0.64	36.38	0.26	14.60
18-11	0.63	37.72	0.23	13.43
18-01	0.63	28.25	0.21	9.21
20-24	0.62	26.77	0.22	9.52
20-19	0.61	37.59	0.18	11.12
13-06	0.60	36.43	0.19	11.79
19-05	0.59	50.98	0.31	27.10
09-100	0.58	27.73	0.15	7.19
13-14	0.57	41.41	0.28	20.60
13-08	0.56	52.30	0.15	14.36
22-08	0.53	31.29	0.18	10.74
09-18	0.53	25.98	0.13	6.49
09-16	0.52	54.29	0.22	22.64
08-18	0.52	67.60	0.20	26.53
13-20	0.52	42.43	0.18	14.71
20-06	0.51	30.72	0.20	12.04
17-02	0.50	22.23	0.13	5.62

14-08	0.49	55.47	0.32	35.76
15-06	0.49	63.36	0.28	35.65
20-10	0.49	19.68	0.17	7.03
12-01	0.49	37.90	0.15	11.57
08-08	0.48	41.88	0.21	18.35
20-29	0.48	28.20	0.12	6.80
22-04	0.46	17.10	0.15	5.67
15-07	0.45	23.71	0.12	6.15
013	0.45	43.35	0.25	23.68
16-04	0.45	47.92	0.16	17.38
19-18	0.44	27.15	0.20	12.04
16-14	0.43	39.92	0.24	21.86
20-15	0.43	20.09	0.12	5.49
12-03	0.42	77.81	0.33	59.82
06-09	0.42	11.62	0.08	2.13
06-05	0.42	27.95	0.20	13.23
15-01	0.42	23.76	0.08	4.55
20-05	0.41	95.43	0.40	93.23
22-09	0.40	21.70	0.08	4.10
16-07	0.40	37.45	0.13	12.44
13-01	0.36	86.33	0.25	60.04
20-08	0.36	87.33	0.20	49.54
19-14	0.35	25.79	0.11	8.11
09-17	0.35	27.33	0.11	8.90
22-13	0.34	31.74	0.11	10.47
22-12	0.34	43.22	0.20	25.42
20-14	0.34	9.59	0.05	1.32
20-09	0.34	47.07	0.17	23.41
18-10	0.33	51.93	0.16	25.64
22-14	0.33	15.71	0.08	3.97
13-21	0.32	24.59	0.10	7.41
002	0.32	30.72	0.14	13.56

18-100	0.31	43.66	0.15	21.27
07-01	0.31	36.48	0.15	17.12
19-10	0.30	64.13	0.20	43.13
22-07	0.26	51.81	0.18	36.20
11-02	0.26	31.45	0.10	11.76
19-20	0.26	29.24	0.08	9.42
06-08	0.26	19.38	0.08	5.84
15-08	0.26	21.46	0.09	7.65
11-01	0.25	2.99	0.02	0.21
22-06	0.24	9.23	0.04	1.46
17-03	0.23	37.76	0.07	11.86
20-12	0.22	44.79	0.08	16.10
14-06	0.22	77.23	0.19	66.46
20-33	0.21	73.61	0.15	52.47
13-15	0.21	81.36	0.15	56.39
20-101	0.21	70.74	0.18	59.50
19-09	0.21	83.28	0.19	76.00
13-04	0.21	42.82	0.10	21.30
06-12	0.20	56.29	0.15	42.14
17-11	0.20	23.35	0.06	6.78
18-05	0.19	32.02	0.10	17.02
10-02	0.18	24.86	0.09	12.37
13-12	0.18	55.15	0.07	22.23
13-05	0.17	15.10	0.03	2.81
18-06	0.17	54.46	0.12	39.78
17-05	0.17	25.72	0.06	9.02
09-01	0.17	28.22	0.04	6.54
12-101	0.16	56.38	0.08	26.49
14-02	0.16	23.55	0.04	6.61
14-11	0.16	78.14	0.11	56.60
21-03	0.16	41.04	0.08	21.09
09-11	0.16	93.53	0.15	90.45

20-31	0.15	69.40	0.09	41.92
14-09	0.14	40.32	0.05	15.04
20-01	0.14	63.65	0.11	50.16
13-03	0.14	31.41	0.08	16.95
04-02	0.14	95.86	0.14	93.85
007	0.14	22.25	0.04	6.58
18-09	0.13	91.37	0.13	87.34
16-01	0.13	41.52	0.08	24.45
009	0.13	31.37	0.06	15.25
20-02	0.12	70.52	0.09	49.00
21-01	0.12	32.35	0.04	10.69
06-11	0.12	36.05	0.05	16.00
19-19	0.11	48.66	0.08	33.94
20-04	0.11	49.74	0.07	29.92
19-06	0.11	34.76	0.06	19.05
19-04	0.10	62.24	0.06	34.90
06-06	0.10	51.29	0.05	27.89
19-07	0.09	94.52	0.08	91.89
15-02	0.08	24.46	0.03	8.89
14-07	0.08	42.30	0.05	27.51
21-02	0.08	87.82	0.07	82.30
09-03	0.07	50.72	0.05	36.12
09-09	0.07	9.78	0.02	3.06
20-13	0.07	98.04	0.06	93.10
19-08	0.06	43.39	0.04	28.58
19-100	0.06	23.86	0.02	8.25
13-09	0.05	89.40	0.04	71.41
20-16	0.05	86.54	0.05	80.51
12-05	0.04	32.78	0.02	18.04
09-04	0.04	86.78	0.04	80.85
14-03	0.04	34.77	0.02	20.50
07-07	0.03	37.47	0.02	22.93

17-06	0.03	94.13	0.03	87.97
13-10	0.03	87.31	0.02	81.16
17-01	0.03	97.94	0.02	80.66
17-10	0.02	82.19	0.01	74.52
14-04	0.01	96.79	0.01	95.23
06-100	0.01	39.10	0.00	17.38
13-11	0.01	88.75	0.00	59.81
13-13	0.00	6.18	0.00	1.53

Table A-2. Impervious and DCIA Amounts for All Town Catchments in the Neponset River Watershed, Sorted by Impervious Area

Catchment Identifier	Impervious Area (Acres)	Percent Impervious	DCIA (Acres)	Percent DCIA
08-21	11.04	45.70	3.42	14.17
02-08	7.20	20.50	0.93	2.65
02-100	5.12	76.15	1.63	24.25
012	5.04	83.12	3.14	51.78
02-09	4.72	22.74	0.64	3.10
08-03	4.48	16.74	0.71	2.67
05-02	4.39	28.40	0.89	5.76
07-100	4.03	21.78	0.55	2.96
05-11	3.91	21.33	0.54	2.97
05-12	3.08	22.28	0.53	3.81
05-07	2.68	24.36	0.60	5.50
05-15	2.67	27.15	0.45	4.57
08-02	2.52	48.53	1.22	23.53
08-13	2.50	32.43	0.43	5.55
05-01	2.43	23.20	0.80	7.58
05-19	2.41	18.64	0.32	2.48
07-04	2.22	7.82	0.13	0.47
05-100	2.17	47.80	0.89	19.73
08-06	2.09	23.70	0.40	4.53

02-04	2.08	20.96	0.46	4.60
08-19	1.81	25.03	0.32	4.40
08-09	1.74	86.47	0.89	44.36
04-03	1.66	21.26	0.26	3.30
05-16	1.58	22.07	0.28	3.94
02-06	1.47	36.59	0.38	9.40
08-07	1.46	47.87	0.53	17.26
015	1.45	29.77	0.48	9.88
05-10	1.44	17.83	0.27	3.32
07-05	1.34	23.29	0.22	3.79
07-06	1.31	38.47	0.37	10.77
02-101	1.19	38.33	0.34	10.97
02-01	1.17	37.14	0.53	16.68
08-22	1.08	35.80	0.66	21.94
07-02	1.05	15.85	0.16	2.41
02-102	0.97	18.30	0.19	3.56
05-14	0.96	30.62	0.33	10.62
05-13	0.85	22.98	0.19	5.14
07-09	0.82	18.55	0.16	3.55
02-10	0.79	46.73	0.42	25.04
05-05	0.78	40.06	0.37	18.77
05-08	0.73	28.52	0.25	9.76
08-14	0.64	13.27	0.14	2.78
011	0.59	22.25	0.18	6.69
08-12	0.57	48.07	0.33	27.42
02-103	0.44	35.53	0.15	12.20
05-20	0.43	15.17	0.12	4.07
05-06	0.39	14.36	0.11	4.08
02-12	0.33	28.12	0.08	7.26
08-20	0.32	73.39	0.21	47.93
02-104	0.28	45.46	0.11	18.70
05-18	0.23	80.42	0.21	70.92



<b>02-02</b>	0.13	50.18	0.05	21.10
<b>02-07</b>	0.13	28.54	0.07	14.90
<b>05-09</b>	0.12	36.59	0.06	19.24
<b>08-05</b>	0.10	90.54	0.10	86.16
<b>02-105</b>	0.08	79.14	0.07	70.00
<b>02-03</b>	0.07	59.28	0.04	39.16
<b>05-03</b>	0.05	99.42	0.04	67.86
<b>08-16</b>	0.05	55.69	0.03	36.99
<b>006</b>	0.04	73.54	0.03	63.07
<b>05-04</b>	0.03	100.00	0.03	100.00
<b>02-11</b>	0.02	3.42	0.00	0.55
<b>02-05</b>	0.02	88.02	0.01	75.46
<b>02-106</b>	0.00	0.00	0.00	0.00

## **Appendix B: Estimated Phosphorus Loading Summary by Catchment**

Table B-1. Estimated Phosphorus Loading for All Town Catchments in the Taunton River Watershed

Catchment Identifier	Estimated P Load (Lbs/Yr)
N/A	227.92
22-100	45.20
12-08	42.04
20-07	34.59
12-103	33.02
04-100	28.21
08-11	26.39
08-15	17.10
09-02	16.92
06-13	15.58
19-12	14.29
010	14.26
12-09	13.70
17-07	12.75
005	12.64
06-02	11.47
04-01	11.07
08-01	10.96
20-26	10.88
13-17	9.67
15-03	9.35
09-19	8.93
20-03	8.85
22-01	8.74
07-03	8.48
19-21	8.20
09-14	8.12
19-03	8.06
08-17	7.76

12-07	7.47
18-07	7.38
014	7.17
09-15	6.65
16-13	6.54
20-11	6.47
06-10	5.68
06-07	5.68
14-01	5.28
09-12	5.03
16-02	4.98
12-11	4.80
08-10	4.70
18-08	4.61
001	4.49
14-13	4.22
12-02	4.11
12-102	4.07
07-08	4.01
13-18	3.86
08-100	3.75
09-101	3.72
12-10	3.63
22-02	3.59
016	3.35
20-35	3.31
14-14	3.31
22-10	3.29
13-02	3.25
22-05	3.21
20-27	3.19

18-03	3.19
19-17	3.19
20-32	3.07
20-102	3.04
19-11	2.92
09-20	2.87
09-10	2.83
20-17	2.72
008	2.66
11-03	2.62
19-15	2.62
09-22	2.55
06-01	2.39
13-100	2.38
22-11	2.35
20-25	2.34
06-04	2.28
17-12	2.25
16-100	2.23
12-04	2.11
16-12	2.10
06-03	2.06
003	2.00
11-04	1.97
004	1.89
19-13	1.88
14-12	1.87
19-16	1.84
12-100	1.79
20-34	1.77
09-21	1.76
13-19	1.74

20-28	1.72
06-09	1.72
19-01	1.69
13-07	1.59
15-05	1.54
17-09	1.53
16-11	1.52
20-100	1.52
22-03	1.52
06-101	1.51
17-04	1.48
10-01	1.46
18-02	1.46
19-02	1.41
20-14	1.38
09-100	1.35
20-19	1.33
16-06	1.33
13-06	1.30
09-18	1.30
14-10	1.29
14-05	1.28
18-101	1.25
18-01	1.22
18-11	1.21
13-08	1.19
20-24	1.19
13-14	1.16
20-29	1.14
15-01	1.12
11-01	1.12
22-06	1.11

19-05	1.09
15-07	1.09
22-14	1.05
09-16	1.03
22-08	1.02
12-01	1.01
17-02	1.00
13-20	0.98
22-04	0.98
08-18	0.97
20-06	0.96
22-09	0.96
20-10	0.96
09-17	0.95
08-08	0.93
14-08	0.92
15-06	0.90
013	0.89
16-07	0.89
06-05	0.88
16-04	0.87
20-15	0.86
19-18	0.84
16-14	0.80
19-14	0.77
12-03	0.77
20-05	0.73
22-13	0.67
13-21	0.67
13-01	0.67
20-08	0.64
15-08	0.63

07-01	0.63
22-12	0.63
20-09	0.62
18-10	0.60
002	0.60
18-100	0.58
19-20	0.58
19-10	0.57
11-02	0.55
06-08	0.51
17-03	0.50
22-07	0.48
13-05	0.48
20-12	0.46
17-11	0.40
14-06	0.39
20-33	0.39
13-15	0.39
20-101	0.39
13-04	0.39
19-09	0.38
13-12	0.38
06-12	0.37
17-05	0.37
18-05	0.35
10-02	0.34
09-01	0.34
09-09	0.33
12-101	0.32
14-02	0.31
18-06	0.31
21-03	0.29

14-11	0.29
007	0.28
20-31	0.28
09-11	0.28
14-09	0.28
009	0.27
13-03	0.26
16-01	0.25
20-01	0.25
04-02	0.25
06-11	0.25
20-02	0.24
18-09	0.24
21-01	0.24
15-02	0.21
20-04	0.21
19-19	0.21
19-06	0.20
19-04	0.19
06-06	0.19
19-07	0.15

14-07	0.14
21-02	0.14
09-03	0.14
19-08	0.12
20-13	0.12
19-100	0.12
13-09	0.09
20-16	0.09
12-05	0.08
09-04	0.08
14-03	0.07
07-07	0.07
17-06	0.05
13-10	0.05
17-01	0.05
17-10	0.03
14-04	0.02
06-100	0.02
13-11	0.01
13-13	0.01



Table B-2. Estimated Phosphorus Loading for All Town Catchments in the Neponset River Watershed

Catchment Identifier	Estimated P Load (Lbs/Yr)
08-21	21.62
02-08	19.54
02-09	13.04
08-03	9.86
02-100	9.49
07-04	9.33
05-02	9.27
07-100	9.22
05-11	8.61
012	8.41
05-12	7.01
05-19	6.43
08-06	5.86
08-02	5.86
05-15	5.79
05-07	5.67
02-04	5.66
08-13	5.42
05-01	4.97
05-100	4.03
08-19	4.02
04-03	3.88
08-07	3.36
07-05	3.24
05-16	3.23
08-09	3.13
07-06	2.93
05-10	2.92
02-06	2.84
015	2.72
02-101	2.68

07-02	2.68
02-102	2.53
08-22	2.52
02-01	2.21
07-09	1.98
05-14	1.84
05-13	1.70
05-08	1.65
05-05	1.53
02-10	1.48
08-14	1.42
011	1.19
05-20	1.18
08-12	0.94
02-103	0.84
05-06	0.83
02-12	0.77
08-20	0.62
02-104	0.52
05-18	0.42
02-07	0.28
02-02	0.25
05-09	0.23
08-05	0.18
02-105	0.15
02-03	0.13
05-03	0.10
08-16	0.08
006	0.07
05-04	0.06
02-11	0.04
02-05	0.03
02-106	0.01

## **Appendix C: Estimated Nitrogen Loading Summary by Catchment**

Table C-1. Estimated Nitrogen Loading for All Catchments in the Taunton River Watershed

Catchment Identifier	Estimated N Load (Lbs/Yr)
N/A	1886.04
22-100	387.13
12-08	327.45
20-07	285.56
12-103	266.65
04-100	224.90
08-11	224.74
09-02	138.48
08-15	130.71
06-13	125.59
010	124.16
19-12	122.00
20-26	116.20
12-09	108.89
005	100.88
06-02	96.51
17-07	96.05
04-01	91.45
15-03	84.39
08-01	82.82
09-14	79.19
09-19	77.69
19-21	73.95
07-03	73.27
19-03	70.86
20-03	70.39
13-17	70.19
22-01	66.82

08-17	60.12
20-11	56.84
09-15	56.70
16-13	56.31
18-07	55.15
12-07	54.99
014	53.64
06-10	50.19
09-12	43.96
06-07	41.01
14-01	39.60
16-02	39.46
08-10	38.93
18-08	34.95
001	34.92
13-18	34.48
12-11	34.01
12-02	33.41
07-08	33.17
14-13	32.28
22-05	32.08
12-102	29.34
20-27	28.72
09-101	28.50
13-02	27.94
22-02	27.44
20-102	26.68
08-100	26.56
12-10	26.35
22-10	26.05

016	25.64
20-35	25.27
19-17	24.69
18-03	24.48
09-20	24.14
20-32	23.52
09-10	21.84
19-11	21.75
11-03	21.39
20-17	20.84
19-15	20.71
008	20.15
09-22	19.87
20-25	19.50
22-11	19.11
06-01	18.86
06-04	18.84
13-100	18.53
16-100	17.58
14-14	17.06
17-12	16.99
19-13	16.37
16-12	16.11
11-01	15.97
11-04	15.81
004	15.78
003	15.71
06-03	15.57
12-04	15.04
06-09	14.64
19-16	14.47
14-12	14.24

19-01	13.96
20-34	13.72
13-19	13.62
12-100	13.57
09-21	13.53
20-28	13.26
13-07	12.10
19-02	11.80
22-03	11.78
09-100	11.72
20-100	11.68
15-05	11.66
06-101	11.63
16-11	11.61
17-09	11.56
10-01	11.49
18-02	11.31
17-04	11.24
09-18	11.15
20-19	10.65
22-06	10.28
13-06	10.12
22-14	10.12
16-06	10.10
20-29	9.86
14-10	9.79
14-05	9.74
13-08	9.68
18-101	9.67
18-01	9.39
13-14	9.36
15-07	9.31

18-11	9.23
20-24	9.18
15-01	8.94
19-05	8.48
09-16	8.37
09-17	8.22
12-01	7.82
22-08	7.82
08-18	7.74
22-09	7.64
17-02	7.63
20-10	7.51
13-20	7.49
20-06	7.47
16-07	7.45
08-08	7.38
06-05	7.24
22-04	7.17
013	7.10
14-08	7.09
16-04	7.06
15-06	7.03
20-15	6.60
19-18	6.59
19-14	6.47
16-14	6.30
12-03	6.03
15-08	5.92
20-14	5.82
20-05	5.78
13-21	5.41
13-01	5.36

22-13	5.07
20-08	5.07
07-01	5.01
22-12	4.97
20-09	4.84
002	4.73
18-10	4.73
19-10	4.56
18-100	4.49
11-02	4.39
17-03	4.11
19-20	4.09
13-05	4.04
06-08	3.98
22-07	3.80
20-12	3.35
20-101	3.20
09-09	3.19
13-15	3.14
14-06	3.12
20-33	3.10
19-09	3.08
13-12	3.02
13-04	3.01
17-11	2.99
06-12	2.90
17-05	2.89
18-05	2.77
10-02	2.75
09-01	2.67
12-101	2.47
18-06	2.42

14-02	2.40
21-03	2.29
14-11	2.27
09-11	2.22
20-31	2.17
007	2.12
16-01	2.06
13-03	2.06
14-09	2.06
15-02	2.05
20-01	2.02
009	2.01
04-02	1.97
06-11	1.96
20-02	1.93
18-09	1.87
21-01	1.81
20-04	1.68
19-19	1.61
19-06	1.57
06-06	1.48
19-04	1.48

19-07	1.23
14-07	1.12
19-08	1.08
21-02	1.08
09-03	1.06
20-13	0.93
19-100	0.89
13-09	0.74
20-16	0.71
12-05	0.66
09-04	0.61
14-03	0.55
07-07	0.50
17-06	0.41
13-10	0.38
17-01	0.36
17-10	0.23
13-13	0.20
14-04	0.15
06-100	0.11
13-11	0.09

Table C-2. Estimated Nitrogen Loading for All Catchments in the Neponset River Watershed

Catchment Identifier	Estimated N Load (Lbs/Yr)
08-21	169.18
02-08	156.13
02-09	108.39
07-04	82.93
02-100	75.78
012	74.10
07-100	72.09
05-02	71.52
08-03	69.90
05-11	69.43
05-12	58.57
05-19	51.66
02-04	49.55
08-06	47.21
05-15	45.55
05-07	45.36
08-02	42.42
08-13	41.49
05-01	37.53
04-03	31.89
08-19	31.52
05-100	31.31
07-05	26.58
08-07	25.44
05-16	25.07
08-09	24.84
07-06	22.72
05-10	22.47
015	21.85
07-02	21.60
02-06	21.51

02-101	20.71
02-01	17.13
02-102	16.45
08-22	16.26
07-09	15.90
05-14	14.19
05-08	12.97
05-13	12.89
05-05	11.77
05-20	11.57
02-10	11.43
08-14	10.35
011	8.89
08-12	8.72
02-12	6.50
02-103	6.37
05-06	6.19
08-20	4.65
02-104	3.99
05-18	3.32
02-07	2.06
02-02	1.84
05-09	1.79
08-05	1.42
02-105	1.15
02-03	0.97
05-03	0.78
08-16	0.65
006	0.53
05-04	0.44
02-11	0.38
02-05	0.22
02-106	0.03



**Appendix D: Town-Owned Parcels Sorted by the NSP  
BMP Tool's Phosphorus Priority Ranking**

Table D-1. Town-Owned Parcels Sorted by BMP Tool Priority Score for Phosphorus Removal

Address	Parloc_ID	Use Description	BMP Tool Priority Score (Max Score = 1)
SPRING STREET	M_222422_865789	Vacant, selectment or City Council	1.0000
GARRETT SPILLANE ROAD	M_220852_871583	Undevelopable land	1.0000
ELM STREET	M_221950_867147	Vacant, selectment or City Council	1.0000
BELCHER ROAD	M_222791_867112	Vacant, selectment or City Council	1.0000
CHASE LANE	M_220406_871777	Vacant, selectment or City Council	1.0000
ALEX LANE	M_222374_865374	Vacant, selectment or City Council	1.0000
CENTRAL STREET	M_222496_865636	Vacant, selectment or City Council	1.0000
COUNTY STREET	M_222998_865724	Vacant, conservation	1.0000
LAKEVIEW ROAD	M_219289_868975	Vacant, conservation	1.0000
LAKEVIEW ROAD	M_219441_868344	Vacant, conservation	1.0000
GRANITE STREET	M_219556_868254	Vacant, conservation	1.0000
LAKEVIEW ROAD	M_219363_868897	Vacant, conservation	1.0000
MAIN STREET	M_219493_868796	Vacant, conservation	1.0000
OAK STREET	M_223012_868810	Vacant, selectment or City Council	1.0000
MILL STREET	M_218275_866643	Vacant, conservation	0.9765
MILL STREET	M_218409_866286	Vacant, conservation	0.9765
BEACH STREET	M_220471_871817	Vacant, selectment or City Council	0.9765
NORTH STREET	M_220633_870125	Vacant, conservation	0.9765
RIDGE ROAD	M_221266_870266	Vacant, selectment or City Council	0.9765
SPRING STREET	M_222292_865724	Vacant, selectment or City Council	0.9765
SPRUCE STREET	M_218286_864857	Vacant, conservation	0.9765
25 PUMPING STATION ROAD	M_221637_869761	Vacant, selectment or City Council	0.9765
MAIN STREET	M_219847_868956	Vacant, conservation	0.9765
110 MAIN STREET	M_219705_868894	Vacant, conservation	0.9765

<b>89 NORTH STREET</b>	M_220456_870480	Vacant, conservation	0.9765
<b>GARLAND LANE</b>	M_218920_866511	Vacant, conservation	0.9692
<b>SPRING STREET</b>	M_222260_865877	Vacant, selectment or City Council	0.9692
<b>SPRING STREET</b>	M_223297_865794	Vacant, selectment or City Council	0.9692
<b>COUNTY STREET</b>	M_222946_865861	Vacant, conservation	0.9692
<b>COMMERCIAL STREET</b>	M_221626_865338	Vacant, selectment or City Council	0.9692
<b>NEPONSET HEIGHTS AVENUE</b>	M_220862_869952	Vacant, selectment or City Council	0.9692
<b>LAKEVIEW ROAD</b>	M_219119_868830	Vacant, conservation	0.9692
<b>MECHANIC STREET</b>	M_221603_868559	Vacant, conservation	0.9692
<b>MAIN STREET</b>	M_219757_868641	Vacant, conservation	0.9692
<b>MAIN STREET</b>	M_219888_868905	Vacant, conservation	0.9692
<b>LINDA STREET</b>	M_223229_869621	Vacant, selectment or City Council	0.9609
<b>EAST STREET</b>	M_225023_869489	Vacant, conservation	0.9609
<b>MILL STREET</b>	M_218464_865882	Vacant, selectment or City Council	0.9609
<b>WILLOW STREET</b>	M_225977_867954	Vacant, conservation	0.9609
<b>MORSE STREET</b>	M_223593_867010	Vacant, selectment or City Council	0.9554
<b>MORSE STREET</b>	M_223730_866813	Vacant, selectment or City Council	0.9554
<b>BELCHER ROAD</b>	M_223166_866604	Vacant, selectment or City Council	0.9554
<b>96-98 MORSE STREET</b>	M_224105_866696	Housing Authority	0.9554
<b>104-106 MORSE STREET</b>	M_224078_866559	Housing Authority	0.9554
<b>MORSE STREET</b>	M_224049_866452	Vacant, selectment or City Council	0.9554
<b>HODGES ROAD</b>	M_224921_867076	Vacant, selectment or City Council	0.9554
<b>EAST STREET</b>	M_225605_867560	Vacant, conservation	0.9554
<b>BELCHER ROAD</b>	M_222411_867647	Vacant, selectment or City Council	0.9554
<b>47 OAK STREET</b>	M_223140_870689	Vacant, selectment or City Council	0.9554
<b>132 MILL STREET</b>	M_218775_865755	Vacant, conservation	0.9554

<b>BLANCHARD STREET</b>	M_222191_865365	Vacant, selectment or City Council	0.9554
<b>58-60 NORTH GROVE STREET</b>	M_219584_864547	Housing Authority	0.9554
<b>CROSS STREET</b>	M_218894_869815	Undevelopable land	0.9554
<b>MECHANIC STREET</b>	M_221852_869896	Improved, Selectmen or City Council	0.9554
<b>WILLOW STREET</b>	M_225845_868698	Vacant, conservation	0.9554
<b>GRANITE STREET</b>	M_219649_868012	Vacant, conservation	0.9554
<b>OAK STREET</b>	M_222907_869280	Vacant, selectment or City Council	0.9554
<b>OAK STREET</b>	M_223724_869304	Utility Authority, Electric, Light, Sewer, Water	0.9554
<b>LAKEVIEW ROAD</b>	M_218838_868806	Vacant, conservation	0.9554
<b>LAKEVIEW ROAD</b>	M_218656_868574	Vacant, conservation	0.9554
<b>COCASSET STREET</b>	M_223357_867783	Vacant, conservation	0.9554
<b>COCASSET STREET</b>	M_223721_867736	Vacant, selectment or City Council	0.9554
<b>EAST STREET</b>	M_225937_867229	Vacant, selectment or City Council	0.9123
<b>MILL STREET</b>	M_218888_866150	Vacant, conservation	0.9123
<b>120 SPRING STREET</b>	M_223583_865993	Vacant, conservation	0.9123
<b>MORSE STREET</b>	M_223641_867638	Vacant, conservation	0.9123
<b>65 ELM STREET</b>	M_221604_867472	Vacant, selectment or City Council	0.9123
<b>BEACH STREET</b>	M_221504_870620	Undevelopable land	0.9123
<b>MECHANIC STREET</b>	M_222604_870378	Vacant, selectment or City Council	0.9123
<b>LINDA STREET</b>	M_223276_869438	Vacant, selectment or City Council	0.9123
<b>OAKWUD TERRACE</b>	M_223282_869173	Vacant, conservation	0.9123
<b>LAKEVIEW ROAD</b>	M_218544_868872	Vacant, conservation	0.9123
<b>LAKEVIEW ROAD</b>	M_218745_868171	Vacant, conservation	0.9123
<b>EAST STREET</b>	M_224870_869135	Vacant, conservation	0.9123
<b>WEST STREET</b>	M_218357_865903	Vacant, selectment or City Council	0.9037
<b>COCASSET STREET</b>	M_222748_868245	Vacant, selectment or City Council	0.9037

<b>OAK STREET</b>	M_223703_869156	Vacant, conservation	0.9037
<b>OAK STREET</b>	M_223664_868986	Improved, Selectmen or City Council	0.9037
<b>11 LAMSON ROAD</b>	M_223853_869481	Improved, Selectmen or City Council	0.9037
<b>MILL STREET</b>	M_219320_865885	Vacant, selectment or City Council	0.9037
<b>COCASSET STREET</b>	M_223683_867909	Vacant, conservation	0.9037
<b>WILLOW STREET</b>	M_225229_868019	Vacant, conservation	0.9037
<b>EAST STREET</b>	M_225595_868589	Vacant, conservation	0.8959
<b>73-75 MORSE STREET</b>	M_224070_866963	Housing Authority	0.8947
<b>SOUTH STREET</b>	M_219678_866263	Vacant, selectment or City Council	0.8947
<b>46 MILL STREET</b>	M_219121_866415	Improved, Selectmen or City Council	0.8947
<b>WILLOW STREET</b>	M_225999_867650	Vacant, conservation	0.8947
<b>ELM STREET</b>	M_221897_866963	Vacant, selectment or City Council	0.8947
<b>WILLOW STREET</b>	M_225783_868476	Vacant, conservation	0.8947
<b>WILLOW STREET</b>	M_225868_868290	Vacant, conservation	0.8947
<b>LAKEVIEW ROAD</b>	M_218800_869073	Vacant, conservation	0.8947
<b>77 MORSE STREET</b>	M_224050_866893	Housing Authority	0.8856
<b>92 MORSE STREET</b>	M_224130_866762	Housing Authority	0.8856
<b>WILLOW STREET</b>	M_225090_867954	Vacant, selectment or City Council	0.8856
<b>EAST STREET</b>	M_225528_868388	Vacant, conservation	0.8837
<b>56 BAKER STREET</b>	M_220412_869133	Housing Authority	0.8824
<b>80 CEDAR STREET</b>	M_217692_863016	Improved, Selectmen or City Council	0.8521
<b>COCASSET STREET</b>	M_223885_867687	Vacant, selectment or City Council	0.8521
<b>WEST STREET</b>	M_218594_865388	Vacant, conservation	0.8417
<b>7 YOUNG ROAD</b>	M_220303_871491	Vacant, selectment or City Council	0.8417
<b>EAST STREET</b>	M_225309_868420	Vacant, conservation	0.8417
<b>170 COCASSET STREET</b>	M_222700_868222	Single family	0.8318
<b>96-98 EAST STREET</b>	M_225205_868772	Housing Authority	0.8318

<b>ELM STREET</b>	M_221990_866808	Vacant, selectment or City Council	0.7896
<b>58 RIDGE ROAD</b>	M_221239_870256	Single family	0.7896
<b>CHESTNUT STREET</b>	M_220392_869926	Vacant, conservation	0.7896
<b>106-108 EAST STREET</b>	M_225143_868504	Housing Authority	0.7886
<b>EAST BELCHER ROAD</b>	M_222545_867103	Vacant, selectment or City Council	0.7854
<b>1 WALNUT TERRACE</b>	M_221256_866378	Housing Authority	0.7854
<b>BEACH STREET</b>	M_220575_871758	Vacant, selectment or City Council	0.7854
<b>CARPENTER STREET</b>	M_220917_867430	Vacant, selectment or City Council	0.7854
<b>COCASSET STREET</b>	M_222878_867513	Vacant, selectment or City Council	0.7854
<b>NORTH STREET</b>	M_220393_870736	Vacant, conservation	0.7854
<b>16 WALDEN FARMS ROAD</b>	M_222918_870177	Vacant, selectment or City Council	0.7854
<b>46-48 NORTH GROVE STREET</b>	M_219479_864627	Housing Authority	0.7854
<b>LAKEVIEW ROAD</b>	M_218751_868749	Vacant, conservation	0.7854
<b>SULLIVAN WAY</b>	M_222339_868741	Vacant, conservation	0.7854
<b>MAIN STREET</b>	M_217887_869516	Vacant, selectment or City Council	0.7854
<b>BRISTOL LANE</b>	M_219048_866688	Vacant, conservation	0.7503
<b>SPRING STREET</b>	M_223456_865845	Vacant, selectment or City Council	0.7503
<b>CARPENTER STREET</b>	M_220808_867425	Vacant, selectment or City Council	0.7503
<b>COCASSET STREET</b>	M_222802_868636	Vacant, selectment or City Council	0.7503
<b>MAIN STREET</b>	M_217985_868752	Vacant, conservation	0.7503
<b>MORSE STREET</b>	M_223987_866151	Vacant, conservation	0.7463
<b>SUMMER STREET</b>	M_224654_867384	Vacant, selectment or City Council	0.7463
<b>REVERE DRIVE</b>	M_224980_867357	Vacant, selectment or City Council	0.7463
<b>WATER STREET</b>	M_219988_867057	Vacant, conservation	0.7463
<b>4 HILLSIDE AVENUE</b>	M_221283_870781	Vacant, selectment or City Council	0.7463
<b>MECHANIC STREET</b>	M_222420_870338	Vacant, selectment or City Council	0.7463

<b>FOXBOROUGH BOULEVARD</b>	M_221923_865416	Vacant, selectment or City Council	0.7463
<b>CENTRAL STREET</b>	M_221995_865380	Vacant, selectment or City Council	0.7463
<b>EAST STREET</b>	M_225196_870034	Undevelopable land	0.7463
<b>COCASSET STREET</b>	M_223764_867795	Vacant, selectment or City Council	0.7463
<b>COCASSET STREET</b>	M_223848_867835	Vacant, selectment or City Council	0.7463
<b>COCASSET STREET</b>	M_222940_867650	Vacant, selectment or City Council	0.7300
<b>EAST STREET</b>	M_225206_870094	Vacant, conservation	0.7300
<b>COCASSET STREET</b>	M_223794_867831	Vacant, selectment or City Council	0.7300
<b>MORSE STREET</b>	M_223707_867173	Vacant, selectment or City Council	0.7265
<b>MORSE STREET</b>	M_223776_866598	Vacant, selectment or City Council	0.7265
<b>MORSE STREET</b>	M_223809_867257	Vacant, selectment or City Council	0.7265
<b>MORSE PLACE</b>	M_224329_867374	Vacant, selectment or City Council	0.7265
<b>MORRIS STREET</b>	M_222140_870973	Vacant, selectment or City Council	0.7265
<b>MORRIS STREET</b>	M_222189_870991	Vacant, selectment or City Council	0.7265
<b>MECHANIC STREET</b>	M_222395_870997	Vacant, selectment or City Council	0.7265
<b>PALMER ROAD</b>	M_222598_870902	Vacant, selectment or City Council	0.7265
<b>BEACH STREET</b>	M_221749_871592	Vacant, selectment or City Council	0.7265
<b>154R MECHANIC STREET</b>	M_221925_870152	Vacant, selectment or City Council	0.7265
<b>SOUTH STREET</b>	M_220509_867591	Vacant, selectment or City Council	0.7201
<b>66-68 BAKER STREET</b>	M_220382_869277	Housing Authority	0.7201
<b>GARLAND LANE</b>	M_219025_866605	Vacant, conservation	0.6999
<b>WASHINGTON STREET</b>	M_218165_870889	Vacant, selectment or City Council	0.6999
<b>COMMERCIAL STREET</b>	M_221693_865169	Vacant, selectment or City Council	0.6999
<b>COCASSET STREET</b>	M_221530_868285	Vacant, conservation	0.6999
<b>BELCHER ROAD</b>	M_222704_867083	Vacant, selectment or City Council	0.6896



<b>OAK STREET</b>	M_222807_869829	Vacant, selectment or City Council	0.6896
<b>YOUNG ROAD</b>	M_220234_871577	Vacant, selectment or City Council	0.6863
<b>WILLOW STREET</b>	M_225408_868241	Vacant, conservation	0.6692
<b>185R MAIN STREET</b>	M_219228_869569	Vacant, selectment or City Council	0.6680
<b>16 MORSE STREET</b>	M_224366_867841	Improved, Education	0.6680
<b>CAMP ROAD</b>	M_221380_870383	Vacant, selectment or City Council	0.6366
<b>COCASSET STREET</b>	M_223900_867736	Vacant, selectment or City Council	0.6366
<b>COCASSET STREET</b>	M_223791_867897	Vacant, selectment or City Council	0.6366
<b>55-57 WILLOW STREET</b>	M_225698_868053	Housing Authority	0.6339
<b>SUMMER STREET</b>	M_224620_867346	Vacant, selectment or City Council	0.5888
<b>110 WASHINGTON STREET</b>	M_218547_869888	Vacant, selectment or City Council	0.5888
<b>102-104 EAST STREET</b>	M_225147_868588	Housing Authority	0.5880
<b>NORTH HIGH STREET</b>	M_221028_866008	Vacant, selectment or City Council	0.5840
<b>SPRING STREET</b>	M_223268_866022	Vacant, selectment or City Council	0.5840
<b>SPRING STREET</b>	M_223283_866033	Vacant, conservation	0.5840
<b>SPRING STREET</b>	M_223203_866010	Vacant, conservation	0.5840
<b>SPRING STREET</b>	M_223255_866103	Vacant, conservation	0.5840
<b>246 CENTRAL STREET</b>	M_221810_866901	Vacant, selectment or City Council	0.5840
<b>CENTRAL STREET</b>	M_222168_865355	Vacant, selectment or City Council	0.5840
<b>SOUTH STREET</b>	M_218844_864818	Vacant, selectment or City Council	0.5840
<b>SOUTH STREET</b>	M_218859_864855	Vacant, selectment or City Council	0.5840
<b>BRADNER STREET</b>	M_221076_865139	Vacant, selectment or City Council	0.5840
<b>WASHINGTON STREET</b>	M_219580_872350	Vacant, selectment or City Council	0.5840
<b>MECHANIC STREET</b>	M_222706_869799	Vacant, selectment or City Council	0.5840
<b>OAK STREET</b>	M_222975_868512	Vacant, selectment or City Council	0.5840

<b>LIBERTY PLACE</b>	M_220695_867998	Improved, Selectmen or City Council	0.5840
<b>3 LIBERTY PLACE</b>	M_220668_868000	Improved, Selectmen or City Council	0.5840
<b>MECHANIC STREET</b>	M_222719_869541	Vacant, selectment or City Council	0.5840
<b>MECHANIC STREET</b>	M_222708_869407	Vacant, selectment or City Council	0.5840
<b>STANILAND ROAD</b>	M_222660_869544	Vacant, selectment or City Council	0.5840
<b>STANILAND ROAD</b>	M_222628_869624	Vacant, selectment or City Council	0.5840
<b>GLENWOOD AVENUE</b>	M_220572_869073	Vacant, selectment or City Council	0.5840
<b>RAILROAD AVENUE</b>	M_220637_868865	Vacant, selectment or City Council	0.5840
<b>MAIN STREET</b>	M_219931_869372	Vacant, selectment or City Council	0.5840
<b>CARPENTER STREET</b>	M_220902_867509	Vacant, conservation	0.5840
<b>WILLOW STREET</b>	M_225814_868956	Vacant, conservation	0.5419
<b>COCASSET STREET</b>	M_223815_867634	Vacant, selectment or City Council	0.5339
<b>SOUTH STREET</b>	M_220588_867648	Improved, Selectmen or City Council	0.5339
<b>CARPENTER STREET</b>	M_220715_867508	Vacant, conservation	0.5339
<b>GRANITE STREET</b>	M_220330_868300	Vacant, selectment or City Council	0.5339
<b>COCASSET STREET</b>	M_221579_868266	Vacant, conservation	0.5339
<b>LAKEVIEW ROAD</b>	M_219380_868639	Vacant, conservation	0.5339
<b>15 MORSE STREET</b>	M_224157_867916	Vacant, selectment or City Council	0.5218
<b>COMMUNITY WAY</b>	M_224571_868022	Vacant, selectment or City Council	0.5218
<b>196 SOUTH STREET</b>	M_220390_866506	Improved, Education	0.5200
<b>MORSE STREET</b>	M_224016_866490	Vacant, selectment or City Council	0.5200
<b>SPRING STREET</b>	M_223184_865918	Vacant, conservation	0.5200
<b>BEACH STREET</b>	M_220435_871945	Vacant, selectment or City Council	0.5200
<b>BEACH STREET</b>	M_220686_872085	Vacant, selectment or City Council	0.5200

<b>120 SOUTH STREET</b>	M_220683_867177	Improved, Education	0.5200
<b>70 ELM STREET</b>	M_221763_867227	Improved, Selectmen or City Council	0.5200
<b>COCASSET STREET</b>	M_222784_867441	Vacant, selectment or City Council	0.5200
<b>CAMP ROAD</b>	M_221455_871096	Vacant, selectment or City Council	0.5200
<b>MORRIS STREET</b>	M_222319_870960	Vacant, selectment or City Council	0.5200
<b>MORRIS STREEET</b>	M_222249_870959	Vacant, selectment or City Council	0.5200
<b>MORRIS STREET</b>	M_222317_870945	Vacant, selectment or City Council	0.5200
<b>69 RIDGE ROAD</b>	M_221189_870390	Vacant, selectment or City Council	0.5200
<b>MECHANIC STREET</b>	M_222034_870244	Vacant, selectment or City Council	0.5200
<b>CEDAR STREET</b>	M_218686_863783	Vacant, conservation	0.5200
<b>WOODS AVENUE</b>	M_222564_871409	Vacant, selectment or City Council	0.5200
<b>WOODS AVENUE</b>	M_222581_871380	Vacant, selectment or City Council	0.5200
<b>6 LAMSON ROAD</b>	M_223670_869606	Utility Authority, Electric, Light, Sewer, Water	0.5200
<b>CHESTNUT STREET</b>	M_221536_869517	Vacant, selectment or City Council	0.5200
<b>SPRING STREET</b>	M_223449_865999	Potentially developable land	0.4792
<b>SOUTH STREET</b>	M_219099_865717	Vacant, conservation	0.4792
<b>BEACH STREET</b>	M_221694_871275	Potentially developable land	0.4792
<b>EDWARDS ROAD</b>	M_221539_871443	Vacant, selectment or City Council	0.4792
<b>10 FAIRBANKS ROAD</b>	M_224035_869540	Vacant, conservation	0.4792
<b>COUNTY STREET</b>	M_223056_865628	Vacant, conservation	0.4739
<b>WEST STREET</b>	M_218533_865332	Vacant, selectment or City Council	0.4689
<b>111 MECHANIC STREET</b>	M_221674_868806	Improved, Education	0.4689
<b>75R MORSE STREET</b>	M_223993_866949	Single family	0.4496
<b>SPRING STREET</b>	M_223833_866487	Vacant, conservation	0.4496
<b>SPRING STREET</b>	M_223356_865801	Vacant, conservation	0.4496
<b>COMMERCIAL STREET</b>	M_221331_867119	Vacant, conservation	0.4496

<b>SOUTH STREET</b>	M_220626_867597	Improved, Selectmen or City Council	0.4496
<b>8 CHESTNUT STREET</b>	M_219985_869475	Improved, Selectmen or City Council	0.4496
<b>HILL STREET</b>	M_222209_871671	Utility Authority, Electric, Light, Sewer, Water	0.4220
<b>BEACH STREET</b>	M_222189_871726	Vacant, selectment or City Council	0.4220
<b>85 WASHINGTON STREET</b>	M_218693_870978	Vacant, selectment or City Council	0.4220
<b>MECHANIC STREET</b>	M_221701_869630	Vacant, selectment or City Council	0.3924
<b>MORRIS STREET</b>	M_222295_870994	Vacant, selectment or City Council	0.3377
<b>JUDGE BROWN LANE</b>	M_224625_867247	Vacant, conservation	0.3144
<b>COCASSET STREET</b>	M_223776_867373	Vacant, selectment or City Council	0.2799
<b>NEPONSET HEIGHTS AVENUE</b>	M_220697_869709	Vacant, selectment or City Council	0.2789
<b>COCASSET STREET</b>	M_223630_867464	Vacant, selectment or City Council	0.2776
<b>41 COUNTY STREET</b>	M_222873_865568	Vacant, selectment or City Council	0.2776
<b>14 COMMUNITY WAY</b>	M_224577_868081	Improved, Education	0.2623
<b>66-68 LEONARD STREET</b>	M_221185_867631	Housing Authority	0.2392
<b>375 SOUTH STREET</b>	M_218982_865219	Improved, Selectmen or City Council	0.2392
<b>22 SOUTH STREET</b>	M_220713_868176	Improved, Selectmen or City Council	0.2392
<b>COMMON</b>	M_220658_868300	Vacant, selectment or City Council	0.2392
<b>39 LEONARD STREET</b>	M_221367_867849	Housing Authority	0.2392
<b>LAKEVIEW ROAD</b>	M_218445_868621	Vacant, conservation	0.1387
	M_221856_870758		0.1342
<b>1 PATRIOT PLACE</b>	M_219490_871218	Improved, Selectmen or City Council	0.1342
<b>NORTH STREET</b>	M_219837_871459	Utility Authority, Electric, Light, Sewer, Water	0.1342

<b>1-40 CENTENNIAL COURT</b>	M_220447_868043	Housing Authority	0.1342
<b>40 SOUTH STREET</b>	M_220691_868058	Improved, Selectmen or City Council	0.1342
<b>75 CENTRAL STREET</b>	M_220841_867967	Improved, Selectmen or City Council	0.1342
<b>70 CARPENTER STREET</b>	M_220623_867874	Improved, Education	0.1342
<b>SOUTH STREET</b>	M_220545_867784	Vacant, selectment or City Council	0.1342
<b>10 BIRD STREET</b>	M_220651_868426	Improved, Selectmen or City Council	0.1342
<b>6 BAKER STREET</b>	M_220637_868467	Vacant, selectment or City Council	0.1342
	M_220524_868267		0.1342
<b>15-17 MARKET STREET</b>	M_220555_868226	Housing Authority	0.1342
<b>COCASSET STREET</b>	M_220797_868209	Vacant, selectment or City Council	0.1342
<b>42 BAKER STREET</b>	M_220500_868961	Housing Authority	0.1342
<b>90 BAKER STREET</b>	M_220516_869194	Housing Authority	0.1342
<b>LEONARD STREET</b>	M_221265_868054	Vacant, selectment or City Council	0.1342
<b>MORSE STREET</b>	M_224234_867624	Vacant, selectment or City Council	0.0276
<b>1 HILLSIDE AVENUE</b>	M_221297_870818	Vacant, selectment or City Council	0.0276
<b>SPRING STREET</b>	M_222875_866627	Vacant, selectment or City Council	0.0082
<b>MORSE STREET</b>	M_223771_867067	Vacant, selectment or City Council	0.0063
<b>SPRING STREET</b>	M_223304_865865	Vacant, conservation	0.0043
<b>LAKEVIEW ROAD</b>	M_219214_868732	Vacant, conservation	0.0043
	M_224784_867260		0.0043
<b>MORSE STREET</b>	M_223917_866835	Vacant, selectment or City Council	0.0037
<b>COCASSET STREET</b>	M_223687_867400	Vacant, selectment or City Council	0.0037
<b>MORSE STREET</b>	M_223689_867284	Vacant, selectment or City Council	0.0037
<b>MAIN STREET</b>	M_218301_869810	Vacant, selectment or City Council	0.0037

<b>LAKEVIEW ROAD</b>	M_219464_868541	Vacant, conservation	0.0037
	M_223511_867636		0.0037
	M_218762_865470		0.0037
	M_223983_866933		0.0037
	M_223804_866994		0.0012

**Appendix E: Town-Owned Parcels Sorted by the NSP  
BMP Tool's Nitrogen Priority Ranking**



Table E-1. Town-Owned Parcels Sorted by BMP Tool Priority Score for Nitrogen Removal

Address	Parloc_ID	Use Description	BMP Tool Priority Score (Max Score = 1)
<b>1 WALNUT TERRACE</b>	M_221256_866378	Housing Authority	0.9840
<b>120 SOUTH STREET</b>	M_220683_867177	Improved, Education	0.9840
<b>56 BAKER STREET</b>	M_220412_869133	Housing Authority	0.9840
<b>75R MORSE STREET</b>	M_223993_866949	Single family	0.9702
<b>16 MORSE STREET</b>	M_224366_867841	Improved, Education	0.9679
<b>OAK STREET</b>	M_223664_868986	Improved, Selectmen or City Council	0.9649
<b>11 LAMSON ROAD</b>	M_223853_869481	Improved, Selectmen or City Council	0.9649
<b>77 MORSE STREET</b>	M_224050_866893	Housing Authority	0.9604
<b>HILL STREET</b>	M_222209_871671	Utility Authority, Electric, Light, Sewer, Water	0.9549
<b>46-48 NORTH GROVE STREET</b>	M_219479_864627	Housing Authority	0.9549
<b>OAK STREET</b>	M_223724_869304	Utility Authority, Electric, Light, Sewer, Water	0.9549
<b>46 MILL STREET</b>	M_219121_866415	Improved, Selectmen or City Council	0.8415
<b>196 SOUTH STREET</b>	M_220390_866506	Improved, Education	0.8415
<b>70 ELM STREET</b>	M_221763_867227	Improved, Selectmen or City Council	0.8415
<b>58-60 NORTH GROVE STREET</b>	M_219584_864547	Housing Authority	0.8415
<b>MECHANIC STREET</b>	M_221852_869896	Improved, Selectmen or City Council	0.8415
<b>170 COCASSET STREET</b>	M_222700_868222	Single family	0.8415

<b>8 CHESTNUT STREET</b>	M_219985_869475	Improved, Selectmen or City Council	0.8415
<b>66-68 BAKER STREET</b>	M_220382_869277	Housing Authority	0.8415
<b>80 CEDAR STREET</b>	M_217692_863016	Improved, Selectmen or City Council	0.7116
<b>111 MECHANIC STREET</b>	M_221674_868806	Improved, Education	0.6470
<b>102-104 EAST STREET</b>	M_225147_868588	Housing Authority	0.6361
<b>92 MORSE STREET</b>	M_224130_866762	Housing Authority	0.6322
<b>58 RIDGE ROAD</b>	M_221239_870256	Single family	0.6322
<b>106-108 EAST STREET</b>	M_225143_868504	Housing Authority	0.6322
<b>55-57 WILLOW STREET</b>	M_225698_868053	Housing Authority	0.6322
<b>73-75 MORSE STREET</b>	M_224070_866963	Housing Authority	0.6243
<b>96-98 MORSE STREET</b>	M_224105_866696	Housing Authority	0.6243
<b>104-106 MORSE STREET</b>	M_224078_866559	Housing Authority	0.6243
<b>96-98 EAST STREET</b>	M_225205_868772	Housing Authority	0.6243
<b>14 COMMUNITY WAY</b>	M_224577_868081	Improved, Education	0.6243
<b>SOUTH STREET</b>	M_220626_867597	Improved, Selectmen or City Council	0.4637
<b>SOUTH STREET</b>	M_220588_867648	Improved, Selectmen or City Council	0.4586
<b>66-68 LEONARD STREET</b>	M_221185_867631	Housing Authority	0.4513
	M_221856_870758		0.4513

<b>1 PATRIOT PLACE</b>	M_219490_871218	Improved, Selectmen or City Council	0.4513
<b>375 SOUTH STREET</b>	M_218982_865219	Improved, Selectmen or City Council	0.4513
<b>NORTH STREET</b>	M_219837_871459	Utility Authority, Electric, Light, Sewer, Water	0.4513
<b>1-40 CENTENNIAL COURT</b>	M_220447_868043	Housing Authority	0.4513
<b>40 SOUTH STREET</b>	M_220691_868058	Improved, Selectmen or City Council	0.4513
<b>75 CENTRAL STREET</b>	M_220841_867967	Improved, Selectmen or City Council	0.4513
<b>LIBERTY PLACE</b>	M_220695_867998	Improved, Selectmen or City Council	0.4513
<b>3 LIBERTY PLACE</b>	M_220668_868000	Improved, Selectmen or City Council	0.4513
<b>70 CARPENTER STREET</b>	M_220623_867874	Improved, Education	0.4513
<b>22 SOUTH STREET</b>	M_220713_868176	Improved, Selectmen or City Council	0.4513
<b>10 BIRD STREET</b>	M_220651_868426	Improved, Selectmen or City Council	0.4513
	M_220524_868267		0.4513
<b>15-17 MARKET STREET</b>	M_220555_868226	Housing Authority	0.4513
<b>42 BAKER STREET</b>	M_220500_868961	Housing Authority	0.4513
<b>90 BAKER STREET</b>	M_220516_869194	Housing Authority	0.4513
<b>39 LEONARD STREET</b>	M_221367_867849	Housing Authority	0.4513
<b>6 LAMSON ROAD</b>	M_223670_869606	Utility Authority, Electric, Light, Sewer, Water	0.1815

<b>SPRING STREET</b>	M_222875_866627	Vacant, selectment or City Council	0.1356
<b>SPRING STREET</b>	M_223304_865865	Vacant, conservation	0.1356
<b>LAKEVIEW ROAD</b>	M_219214_868732	Vacant, conservation	0.1356
<b>SPRING STREET</b>	M_223184_865918	Vacant, conservation	0.1334
<b>BEACH STREET</b>	M_220435_871945	Vacant, selectment or City Council	0.1326
<b>ELM STREET</b>	M_221897_866963	Vacant, selectment or City Council	0.1326
<b>CARPENTER STREET</b>	M_220715_867508	Vacant, conservation	0.1326
<b>COMMERCIAL STREET</b>	M_221693_865169	Vacant, selectment or City Council	0.1326
<b>LAKEVIEW ROAD</b>	M_219380_868639	Vacant, conservation	0.1326
<b>BEACH STREET</b>	M_220686_872085	Vacant, selectment or City Council	0.1302
<b>SPRING STREET</b>	M_222260_865877	Vacant, selectment or City Council	0.1292
<b>SPRING STREET</b>	M_223297_865794	Vacant, selectment or City Council	0.1292
<b>COUNTY STREET</b>	M_222946_865861	Vacant, conservation	0.1292
<b>BEACH STREET</b>	M_220575_871758	Vacant, selectment or City Council	0.1292
<b>MECHANIC STREET</b>	M_222420_870338	Vacant, selectment or City Council	0.1292
<b>FOXBOROUGH BOULEVARD</b>	M_221923_865416	Vacant, selectment or City Council	0.1292
<b>CENTRAL STREET</b>	M_221995_865380	Vacant, selectment or City Council	0.1292
<b>COMMERCIAL STREET</b>	M_221626_865338	Vacant, selectment or City Council	0.1292
<b>COCASSET STREET</b>	M_222748_868245	Vacant, selectment or City Council	0.1292

<b>LAKEVIEW ROAD</b>	M_219119_868830	Vacant, conservation	0.1292
<b>MECHANIC STREET</b>	M_221603_868559	Vacant, conservation	0.1292
<b>MAIN STREET</b>	M_219757_868641	Vacant, conservation	0.1292
<b>MAIN STREET</b>	M_219888_868905	Vacant, conservation	0.1292
<b>EAST STREET</b>	M_225937_867229	Vacant, selectment or City Council	0.1244
<b>BRISTOL LANE</b>	M_219048_866688	Vacant, conservation	0.1244
<b>MILL STREET</b>	M_218409_866286	Vacant, conservation	0.1244
<b>BEACH STREET</b>	M_220471_871817	Vacant, selectment or City Council	0.1244
<b>ELM STREET</b>	M_221990_866808	Vacant, selectment or City Council	0.1244
<b>CARPENTER STREET</b>	M_220808_867425	Vacant, selectment or City Council	0.1244
<b>65 ELM STREET</b>	M_221604_867472	Vacant, selectment or City Council	0.1244
<b>MECHANIC STREET</b>	M_222604_870378	Vacant, selectment or City Council	0.1244
<b>SPRING STREET</b>	M_222292_865724	Vacant, selectment or City Council	0.1244
<b>SPRUCE STREET</b>	M_218286_864857	Vacant, conservation	0.1244
<b>WILLOW STREET</b>	M_225408_868241	Vacant, conservation	0.1244
<b>LAKEVIEW ROAD</b>	M_218745_868171	Vacant, conservation	0.1244
<b>110 MAIN STREET</b>	M_219705_868894	Vacant, conservation	0.1244
<b>COCASSET STREET</b>	M_222802_868636	Vacant, selectment or City Council	0.1244
<b>EAST STREET</b>	M_224870_869135	Vacant, conservation	0.1244
<b>OAK STREET</b>	M_222807_869829	Vacant, selectment or City Council	0.1244
<b>89 NORTH STREET</b>	M_220456_870480	Vacant, conservation	0.1244
<b>MORSE STREET</b>	M_223771_867067	Vacant, selectment or City Council	0.1184

<b>MORSE STREET</b>	M_223917_866835	Vacant, selectment or City Council	0.1184
<b>SPRING STREET</b>	M_222422_865789	Vacant, selectment or City Council	0.1184
<b>COCASSET STREET</b>	M_223687_867400	Vacant, selectment or City Council	0.1184
<b>MORSE STREET</b>	M_223689_867284	Vacant, selectment or City Council	0.1184
<b>ELM STREET</b>	M_221950_867147	Vacant, selectment or City Council	0.1184
<b>BELCHER ROAD</b>	M_222411_867647	Vacant, selectment or City Council	0.1184
<b>COCASSET STREET</b>	M_222784_867441	Vacant, selectment or City Council	0.1184
<b>COCASSET STREET</b>	M_222878_867513	Vacant, selectment or City Council	0.1184
<b>ALEX LANE</b>	M_222374_865374	Vacant, selectment or City Council	0.1184
<b>CENTRAL STREET</b>	M_222496_865636	Vacant, selectment or City Council	0.1184
<b>COUNTY STREET</b>	M_222998_865724	Vacant, conservation	0.1184
<b>NORTH STREET</b>	M_220393_870736	Vacant, conservation	0.1184
<b>MAIN STREET</b>	M_218301_869810	Vacant, selectment or City Council	0.1184
<b>WILLOW STREET</b>	M_225845_868698	Vacant, conservation	0.1184
<b>OAK STREET</b>	M_222907_869280	Vacant, selectment or City Council	0.1184
<b>LAKEVIEW ROAD</b>	M_219441_868344	Vacant, conservation	0.1184
<b>OAK STREET</b>	M_223012_868810	Vacant, selectment or City Council	0.1184
	M_223511_867636		0.1184
<b>EAST STREET</b>	M_225309_868420	Vacant, conservation	0.1096

<b>MORSE STREET</b>	M_223707_867173	Vacant, selectment or City Council	0.1093
<b>COCASSET STREET</b>	M_223776_867373	Vacant, selectment or City Council	0.1093
<b>MORSE STREET</b>	M_223809_867257	Vacant, selectment or City Council	0.1093
	M_224784_867260		0.1093
<b>WEST STREET</b>	M_218533_865332	Vacant, selectment or City Council	0.1081
<b>COCASSET STREET</b>	M_222940_867650	Vacant, selectment or City Council	0.1075
<b>EAST STREET</b>	M_225595_868589	Vacant, conservation	0.1075
<b>MILL STREET</b>	M_218464_865882	Vacant, selectment or City Council	0.1075
<b>WILLOW STREET</b>	M_225229_868019	Vacant, conservation	0.1068
<b>YOUNG ROAD</b>	M_220234_871577	Vacant, selectment or City Council	0.1066
<b>LAKEVIEW ROAD</b>	M_218800_869073	Vacant, conservation	0.1066
<b>COCASSET STREET</b>	M_223885_867687	Vacant, selectment or City Council	0.1066
<b>COCASSET STREET</b>	M_223791_867897	Vacant, selectment or City Council	0.1066
<b>120 SPRING STREET</b>	M_223583_865993	Vacant, conservation	0.1053
<b>OAKWUD TERRACE</b>	M_223282_869173	Vacant, conservation	0.1053
<b>SPRING STREET</b>	M_223833_866487	Vacant, conservation	0.1046
<b>LINDA STREET</b>	M_223229_869621	Vacant, selectment or City Council	0.1041
<b>EAST STREET</b>	M_225023_869489	Vacant, conservation	0.1041
<b>GARLAND LANE</b>	M_218920_866511	Vacant, conservation	0.1031
<b>MORSE STREET</b>	M_223776_866598	Vacant, selectment or City Council	0.1031



<b>WEST STREET</b>	M_218357_865903	Vacant, selectment or City Council	0.1031
<b>COCASSET STREET</b>	M_223815_867634	Vacant, selectment or City Council	0.1031
<b>WATER STREET</b>	M_219988_867057	Vacant, conservation	0.1031
<b>BEACH STREET</b>	M_221749_871592	Vacant, selectment or City Council	0.1031
<b>EAST STREET</b>	M_225528_868388	Vacant, conservation	0.1031
<b>OAK STREET</b>	M_223703_869156	Vacant, conservation	0.1031
<b>MILL STREET</b>	M_219320_865885	Vacant, selectment or City Council	0.1031
<b>COCASSET STREET</b>	M_223683_867909	Vacant, conservation	0.1031
<b>MILL STREET</b>	M_218275_866643	Vacant, conservation	0.0990
<b>MILL STREET</b>	M_218888_866150	Vacant, conservation	0.0990
<b>MORSE STREET</b>	M_223641_867638	Vacant, conservation	0.0990
<b>LAKEVIEW ROAD</b>	M_218544_868872	Vacant, conservation	0.0990
<b>MAIN STREET</b>	M_217985_868752	Vacant, conservation	0.0990
<b>WILLOW STREET</b>	M_225090_867954	Vacant, selectment or City Council	0.0990
<b>EAST BELCHER ROAD</b>	M_222545_867103	Vacant, selectment or City Council	0.0966
<b>MORSE STREET</b>	M_223730_866813	Vacant, selectment or City Council	0.0966
<b>BELCHER ROAD</b>	M_223166_866604	Vacant, selectment or City Council	0.0966
<b>BEACH STREET</b>	M_222189_871726	Vacant, selectment or City Council	0.0966
<b>CARPENTER STREET</b>	M_220917_867430	Vacant, selectment or City Council	0.0966
<b>132 MILL STREET</b>	M_218775_865755	Vacant, conservation	0.0966
<b>85 WASHINGTON STREET</b>	M_218693_870978	Vacant, selectment or City Council	0.0966

<b>16 WALDEN FARMS ROAD</b>	M_222918_870177	Vacant, selectment or City Council	0.0966
<b>WILLOW STREET</b>	M_225868_868290	Vacant, conservation	0.0966
<b>LAKEVIEW ROAD</b>	M_218838_868806	Vacant, conservation	0.0966
<b>LAKEVIEW ROAD</b>	M_218751_868749	Vacant, conservation	0.0966
<b>LAKEVIEW ROAD</b>	M_218445_868621	Vacant, conservation	0.0966
<b>SULLIVAN WAY</b>	M_222339_868741	Vacant, conservation	0.0966
<b>MAIN STREET</b>	M_217887_869516	Vacant, selectment or City Council	0.0966
<b>COCASSET STREET</b>	M_223357_867783	Vacant, conservation	0.0966
<b>COCASSET STREET</b>	M_223721_867736	Vacant, selectment or City Council	0.0966
<b>COCASSET STREET</b>	M_223764_867795	Vacant, selectment or City Council	0.0966
<b>COUNTY STREET</b>	M_223056_865628	Vacant, conservation	0.0813
<b>NEPONSET HEIGHTS AVENUE</b>	M_220697_869709	Vacant, selectment or City Council	0.0813
<b>WILLOW STREET</b>	M_225999_867650	Vacant, conservation	0.0800
<b>GARLAND LANE</b>	M_219025_866605	Vacant, conservation	0.0792
<b>MORSE PLACE</b>	M_224329_867374	Vacant, selectment or City Council	0.0792
<b>NORTH STREET</b>	M_220633_870125	Vacant, conservation	0.0780
<b>RIDGE ROAD</b>	M_221266_870266	Vacant, selectment or City Council	0.0780
<b>25 PUMPING STATION ROAD</b>	M_221637_869761	Vacant, selectment or City Council	0.0780
<b>LINDA STREET</b>	M_223276_869438	Vacant, selectment or City Council	0.0780
<b>MAIN STREET</b>	M_219847_868956	Vacant, conservation	0.0780
<b>CHESTNUT STREET</b>	M_220392_869926	Vacant, conservation	0.0780
<b>HODGES ROAD</b>	M_224921_867076	Vacant, selectment or City Council	0.0753

<b>EAST STREET</b>	M_225605_867560	Vacant, conservation	0.0753
<b>GARRETT SPILLANE ROAD</b>	M_220852_871583	Undevelopable land	0.0753
<b>SOUTH STREET</b>	M_220509_867591	Vacant, selectment or City Council	0.0753
<b>BELCHER ROAD</b>	M_222791_867112	Vacant, selectment or City Council	0.0753
<b>CHASE LANE</b>	M_220406_871777	Vacant, selectment or City Council	0.0753
<b>BLANCHARD STREET</b>	M_222191_865365	Vacant, selectment or City Council	0.0753
<b>CROSS STREET</b>	M_218894_869815	Undevelopable land	0.0753
<b>GRANITE STREET</b>	M_219649_868012	Vacant, conservation	0.0753
<b>LAKEVIEW ROAD</b>	M_219289_868975	Vacant, conservation	0.0753
<b>LAKEVIEW ROAD</b>	M_218656_868574	Vacant, conservation	0.0753
<b>GRANITE STREET</b>	M_219556_868254	Vacant, conservation	0.0753
<b>LAKEVIEW ROAD</b>	M_219363_868897	Vacant, conservation	0.0753
<b>MAIN STREET</b>	M_219493_868796	Vacant, conservation	0.0753
<b>185R MAIN STREET</b>	M_219228_869569	Vacant, selectment or City Council	0.0753
<b>COCASSET STREET</b>	M_223630_867464	Vacant, selectment or City Council	0.0609
<b>BELCHER ROAD</b>	M_222704_867083	Vacant, selectment or City Council	0.0602
<b>WASHINGTON STREET</b>	M_218165_870889	Vacant, selectment or City Council	0.0599
<b>7 YOUNG ROAD</b>	M_220303_871491	Vacant, selectment or City Council	0.0599
<b>NEPONSET HEIGHTS AVENUE</b>	M_220862_869952	Vacant, selectment or City Council	0.0599
<b>COCASSET STREET</b>	M_221530_868285	Vacant, conservation	0.0559

<b>COCASSET STREET</b>	M_223900_867736	Vacant, selectment or City Council	0.0559
<b>WILLOW STREET</b>	M_225977_867954	Vacant, conservation	0.0544
<b>SPRING STREET</b>	M_223449_865999	Potentially developable land	0.0531
<b>CEDAR STREET</b>	M_218686_863783	Vacant, conservation	0.0529
<b>SPRING STREET</b>	M_223456_865845	Vacant, selectment or City Council	0.0519
<b>BEACH STREET</b>	M_221504_870620	Undevelopable land	0.0519
<b>COCASSET STREET</b>	M_223794_867831	Vacant, selectment or City Council	0.0519
<b>MORSE STREET</b>	M_223593_867010	Vacant, selectment or City Council	0.0511
<b>SOUTH STREET</b>	M_219678_866263	Vacant, selectment or City Council	0.0511
<b>MORSE STREET</b>	M_224049_866452	Vacant, selectment or City Council	0.0511
<b>47 OAK STREET</b>	M_223140_870689	Vacant, selectment or City Council	0.0511
<b>WEST STREET</b>	M_218594_865388	Vacant, conservation	0.0511
<b>41 COUNTY STREET</b>	M_222873_865568	Vacant, selectment or City Council	0.0511
<b>WILLOW STREET</b>	M_225783_868476	Vacant, conservation	0.0511
<b>LAKEVIEW ROAD</b>	M_219464_868541	Vacant, conservation	0.0511
	M_218762_865470		0.0511
<b>SUMMER STREET</b>	M_224620_867346	Vacant, selectment or City Council	0.0401
<b>SPRING STREET</b>	M_223356_865801	Vacant, conservation	0.0396
<b>COMMERCIAL STREET</b>	M_221331_867119	Vacant, conservation	0.0396
<b>CAMP ROAD</b>	M_221380_870383	Vacant, selectment or City Council	0.0396

<b>GRANITE STREET</b>	M_220330_868300	Vacant, selectment or City Council	0.0379
<b>COCASSET STREET</b>	M_221579_868266	Vacant, conservation	0.0379
<b>EAST STREET</b>	M_225206_870094	Vacant, conservation	0.0366
<b>WILLOW STREET</b>	M_225814_868956	Vacant, conservation	0.0366
<b>NORTH HIGH STREET</b>	M_221028_866008	Vacant, selectment or City Council	0.0351
<b>SPRING STREET</b>	M_223268_866022	Vacant, selectment or City Council	0.0351
<b>SPRING STREET</b>	M_223283_866033	Vacant, conservation	0.0351
<b>SPRING STREET</b>	M_223203_866010	Vacant, conservation	0.0351
<b>SPRING STREET</b>	M_223255_866103	Vacant, conservation	0.0351
<b>MORSE STREET</b>	M_223987_866151	Vacant, conservation	0.0351
<b>SUMMER STREET</b>	M_224654_867384	Vacant, selectment or City Council	0.0351
<b>REVERE DRIVE</b>	M_224980_867357	Vacant, selectment or City Council	0.0351
<b>246 CENTRAL STREET</b>	M_221810_866901	Vacant, selectment or City Council	0.0351
<b>4 HILLSIDE AVENUE</b>	M_221283_870781	Vacant, selectment or City Council	0.0351
<b>MORRIS STREET</b>	M_222140_870973	Vacant, selectment or City Council	0.0351
<b>MORRIS STREET</b>	M_222189_870991	Vacant, selectment or City Council	0.0351
<b>MECHANIC STREET</b>	M_222395_870997	Vacant, selectment or City Council	0.0351
<b>PALMER ROAD</b>	M_222598_870902	Vacant, selectment or City Council	0.0351
<b>CENTRAL STREET</b>	M_222168_865355	Vacant, selectment or City Council	0.0351

<b>SOUTH STREET</b>	M_218844_864818	Vacant, selectment or City Council	0.0351
<b>SOUTH STREET</b>	M_218859_864855	Vacant, selectment or City Council	0.0351
<b>BRADNER STREET</b>	M_221076_865139	Vacant, selectment or City Council	0.0351
<b>WASHINGTON STREET</b>	M_219580_872350	Vacant, selectment or City Council	0.0351
<b>MECHANIC STREET</b>	M_222706_869799	Vacant, selectment or City Council	0.0351
<b>OAK STREET</b>	M_222975_868512	Vacant, selectment or City Council	0.0351
<b>SOUTH STREET</b>	M_220545_867784	Vacant, selectment or City Council	0.0351
<b>MECHANIC STREET</b>	M_222719_869541	Vacant, selectment or City Council	0.0351
<b>MECHANIC STREET</b>	M_222708_869407	Vacant, selectment or City Council	0.0351
<b>STANILAND ROAD</b>	M_222660_869544	Vacant, selectment or City Council	0.0351
<b>STANILAND ROAD</b>	M_222628_869624	Vacant, selectment or City Council	0.0351
<b>6 BAKER STREET</b>	M_220637_868467	Vacant, selectment or City Council	0.0351
<b>COCASSET STREET</b>	M_220797_868209	Vacant, selectment or City Council	0.0351
<b>COMMON</b>	M_220658_868300	Vacant, selectment or City Council	0.0351
<b>GLENWOOD AVENUE</b>	M_220572_869073	Vacant, selectment or City Council	0.0351
<b>RAILROAD AVENUE</b>	M_220637_868865	Vacant, selectment or City Council	0.0351

<b>EAST STREET</b>	M_225196_870034	Undevelopable land	0.0351
<b>MAIN STREET</b>	M_219931_869372	Vacant, selectment or City Council	0.0351
	M_223804_866994		0.0351
<b>CARPENTER STREET</b>	M_220902_867509	Vacant, conservation	0.0351
<b>LEONARD STREET</b>	M_221265_868054	Vacant, selectment or City Council	0.0351
<b>COCASSET STREET</b>	M_223848_867835	Vacant, selectment or City Council	0.0351
	M_223983_866933		0.0133
<b>MORRIS STREEET</b>	M_222295_870994	Vacant, selectment or City Council	0.0130
<b>15 MORSE STREET</b>	M_224157_867916	Vacant, selectment or City Council	0.0121
<b>COMMUNITY WAY</b>	M_224571_868022	Vacant, selectment or City Council	0.0121
<b>SOUTH STREET</b>	M_219099_865717	Vacant, conservation	0.0111
<b>BEACH STREET</b>	M_221694_871275	Potentially developable land	0.0111
<b>EDWARDS ROAD</b>	M_221539_871443	Vacant, selectment or City Council	0.0111
<b>10 FAIRBANKS ROAD</b>	M_224035_869540	Vacant, conservation	0.0111
<b>MORSE STREET</b>	M_224016_866490	Vacant, selectment or City Council	0.0098
<b>MORSE STREET</b>	M_224234_867624	Vacant, selectment or City Council	0.0098
<b>JUDGE BROWN LANE</b>	M_224625_867247	Vacant, conservation	0.0098
<b>CAMP ROAD</b>	M_221455_871096	Vacant, selectment or City Council	0.0098



<b>1 HILLSIDE AVENUE</b>	M_221297_870818	Vacant, selectment or City Council	0.0098
<b>MORRIS STREET</b>	M_222319_870960	Vacant, selectment or City Council	0.0098
<b>MORRIS STREEET</b>	M_222249_870959	Vacant, selectment or City Council	0.0098
<b>MORRIS STREET</b>	M_222317_870945	Vacant, selectment or City Council	0.0098
<b>69 RIDGE ROAD</b>	M_221189_870390	Vacant, selectment or City Council	0.0098
<b>MECHANIC STREET</b>	M_222034_870244	Vacant, selectment or City Council	0.0098
<b>WOODS AVENUE</b>	M_222564_871409	Vacant, selectment or City Council	0.0098
<b>WOODS AVENUE</b>	M_222581_871380	Vacant, selectment or City Council	0.0098
<b>CHESTNUT STREET</b>	M_221536_869517	Vacant, selectment or City Council	0.0098
<b>110 WASHINGTON STREET</b>	M_218547_869888	Vacant, selectment or City Council	0.0015
<b>154R MECHANIC STREET</b>	M_221925_870152	Vacant, selectment or City Council	0.0012
<b>MECHANIC STREET</b>	M_221701_869630	Vacant, selectment or City Council	0.0007